

2023

**B&B**  
**ITALIA** **OUTDOOR**

The Outdoor Collection

# The Outdoor Collection | 2023

The success of B&B Italia Outdoor can be measured by its consistency and results, distinguishing features in the evolution of the collection since its launch in 2007.

B&B Italia was the first company in its category to strive towards developing a range of outdoor furniture, aiming to bring the intrinsic qualities of its indoor collections to outdoor designs, replicating an experience outside the home that was previously only possible inside, without compromising on product excellence.

Today, the strength of that decision is reflected not only in the variety of the offering, but also in the steady growth of sales success.

## Values

For B&B Italia, quality means pushing forward and rewriting traditional design codes to create excellent products.

**Research and technological innovation** are conveyed through the continuous investigation to discover new materials and construction solutions. **Ergonomics and comfort** are expressed in new ways in each outdoor collection to make relaxation tangible without compromising on impeccable aesthetic. **Creativity** is another distinctive trait.

At times subtle, at times obvious, the ability to create the unthinkable is interpreted in different ways that embrace every style. The outdoor collections are capable of enhancing any interior, providing customers and interior decorators with such a choice in terms of range and features.

## Sustainability

Being mindful of the environment is particularly relevant when it comes to outdoor living. That's why sustainability has been of intrinsic importance for B&B Italia outdoor since its very first collections.

Even when not made explicit, it is something that has been practised through the use of recycled and recyclable materials, associated with structures that can be easily disassembled.

These steps, and those that will come after, are making the circular economy a concrete reality for B&B Italia, as we move towards a new understanding of design and its industrial processes.

Una storia di successo si misura attraverso coerenza e risultati, fattori che contraddistinguono l'evoluzione della collezione outdoor di B&B Italia, dal suo lancio nel 2007.

B&B Italia è stata di fatto la prima azienda della sua categoria a perseguire con decisione l'idea di una linea di arredi outdoor con l'obiettivo di portare all'esterno le qualità intrinseche delle sue collezioni indoor, senza scendere a compromessi con l'eccellenza del prodotto.

Oggi la forza di tale scelta si rispecchia nella notorietà globale delle collezioni, nella varietà dell'offerta ma anche in un successo di vendite in costante crescita.

## Valori

Per B&B Italia qualità significa spinta in avanti e riscrittura dei codici della tradizione per creare prodotti d'eccellenza.

**Ricerca e innovazione tecnologica** si esprimono attraverso la continua indagine alla scoperta di nuovi materiali e soluzioni costruttive.

**Ergonomia e comfort** trovano forme di espressione sempre nuove per rendere tangibile un relax che non rinuncia a un'estetica sempre impeccabile.

Non può mancare la **creatività**. A volte sussurrata, a volte palese, troviamo questa capacità di pensare l'impensabile in molte declinazioni che abbracciano ogni stile, offrendo a clienti e interior decorator una scelta unica nel suo genere per ampiezza e caratteristiche.

## Sostenibilità

L'attenzione all'ambiente diventa particolarmente rilevante nella vita all'aria aperta. Per questo l'outdoor di B&B Italia ha messo al centro la sostenibilità fin dalle sue prime collezioni. Pensiero costante, anche quando non dichiarato esplicitamente, è stato messo in pratica attraverso l'uso di materiali riciclati e riciclabili, associati a strutture facilmente disassemblabili.

Grazie a questi passi e a quelli che seguiranno, l'economia circolare diventa reale e concreta per B&B Italia, nella direzione di una nuova concezione del design e dei suoi processi industriali.



# The Outdoor Collection | 2023

## Product inspiration

### Product index

### Indice prodotti

	Inspiration	Specifications		Inspiration	Specifications
Allure O' Outdoor • Monica Armani	45	16	Husk Outdoor • Patricia Urquiola	294	148
Awa Outdoor • Naoto Fukasawa	312	20	Hybrid • Antonio Citterio	117	154
Ayana • Naoto Fukasawa	105	22	Kaleidos • B&B Italia CR&S	328	164
Bay • Nipa Doshi & Jonathan Levien	231	32	Kyra • B&B Italia CR&S	324	166
Borea • Piero Lissoni	81	40	Link Outdoor • Jakob Wagner	284	168
Butterfly • Patricia Urquiola	245	58	Mirto Outdoor • Antonio Citterio	181	170
Canasta • Patricia Urquiola	259	62	Nooch • Piero Lissoni	5	190
Canasta tables • Patricia Urquiola	264	68	Oh, it rains! • Philippe Starck	129	202
Canasta '13 • Patricia Urquiola	268	72	Overscale Flames Outdoor •		
Charles Outdoor • Antonio Citterio	219	78	Jean-Marie Massaud	316	206
Colosseo Outdoor • Naoto Fukasawa	308	84	Pablo Outdoor • Vincent Van Duysen	63	208
Cordoba Outdoor • Foster+Partners, Industrial Design Studio	37	86	Papilio Shell Outdoor • Naoto Fukasawa	292	222
Cosmos Outdoor • Jeffrey Bernett	288	90	Piet • B&B Italia CR&S	326	224
Crinoline • Patricia Urquiola	275	92	Pushpam • Naoto Fukasawa	290	226
Erica • Antonio Citterio	161	98	Ray Outdoor Fabric • Antonio Citterio	200	228
Erica '19 • Antonio Citterio	161	104	Ray Outdoor Natural • Antonio Citterio	206	234
Fat-Fat Outdoor • Patricia Urquiola	310	116	Ribes • Antonio Citterio	141	242
Fat-Sofa Outdoor • Patricia Urquiola	253	118	Spool Outdoor • Piero Lissoni	298	260
Flair O' Outdoor • Monica Armani	55	122	Springtime • Jean-Marie Massaud	320	262
Frank Outdoor • Antonio Citterio	322	126	Titikaka • Naoto Fukasawa	314	264
Ginepro • Antonio Citterio	225	128	Tobi-Ishi Outdoor •		
Ginestra • Antonio Citterio	239	132	Edward Barber & Jay Osgerby	282	266
Gio • Antonio Citterio	209	136	Tramae • unPIZZO	300	268
Hospes • B&B Italia CR&S	304	146	Twist • B&B Italia CR&S	328	270
			White Collection • Marcel Wanders	318	272
			Fabrics		274
			Dedicated fabrics		282
			Contacts		284

go to  
**Visual index**  
 indice visivo



# Nooch

Piero Lissoni

“Nooch is a large connection of small pieces. If you combine them together, the collection becomes a huge family of different dynamic and endless solutions. The name Nooch is in-between England and Asia and means bamboo labyrinth. The structure of the seating system is like a labyrinth but made in aluminum.”

Piero Lissoni

“Nooch è una grande connessione di piccoli pezzi. Se li combini insieme, la collezione diventa una grande famiglia di diverse soluzioni dinamiche e infinite. Il nome Nooch è a metà tra Inghilterra e Asia e significa labirinto in bambù. La struttura del sistema di sedute è come un labirinto, ma realizzata in alluminio.”

Piero Lissoni







Previous and opposite:  
Nooch, modular sofa • NH95TS • NH95C • NH95PQ •  
NH1P\_L • NH95PQ • NH95TD • NH60\_SB • TNH32\_L

Nooch, low tables • TNH95Q  
Spool Outdoor, round small table • OS40T

Nelle pagine precedenti e nella pagina accanto:  
Nooch, divano componibile • NH95TS • NH95C • NH95PQ •  
NH1P\_L • NH95PQ • NH95TD • NH60\_SB • TNH32\_L

Nooch, tavoli bassi • TNH95Q  
Spool Outdoor, tavolino rotondo • OS40T



These pages:  
[Nooch, service element • TNH32\\_L](#)

In queste pagine:  
[Nooch, elemento di servizio • TNH32\\_L](#)



This page:  
 Nooch, central element • NH95C

Opposite:  
 Nooch, modular sofa • NH1P\_L • NH95PQ • NH60\_SB  
 NH95C • NH95TD

In questa pagina:  
 Nooch, elemento centrale • NH95C

Nella pagina accanto:  
 Nooch, divano componibile • NH1P\_L • NH95PQ • NH60\_SB  
 NH95C • NH95TD





Opposite:  
Nooch, low tables • TNH95Q

---

Nella pagina accanto:  
Nooch, tavolo basso • TNH95Q

---



These pages:  
Nooch, modular sofa • NH95TS • NH3P\_L • NH136C •  
NH3P\_L • NH95TD

In queste pagine:  
Nooch, divano componibile • NH95TS • NH3P\_L • NH136C •  
NH3P\_L • NH95TD



Opposite:  
 Nooch, modular sofa • NH95TS • NH3P\_L • NH136C

Next pages:  
 Nooch, modular sofa • NH95TS • NH95TD • NH95PQ • NH95PQ  
 Spool Outdoor, round small table, OS40T

Nella pagina accanto:  
 Nooch, divano componibile • NH95TS • NH3P\_L • NH136C

Nelle pagine successive: Nooch, divano componibile  
 NH95TS • NH95TD • NH95PQ • NH95PQ  
 Spool Outdoor, tavolino rotondo, OS40T



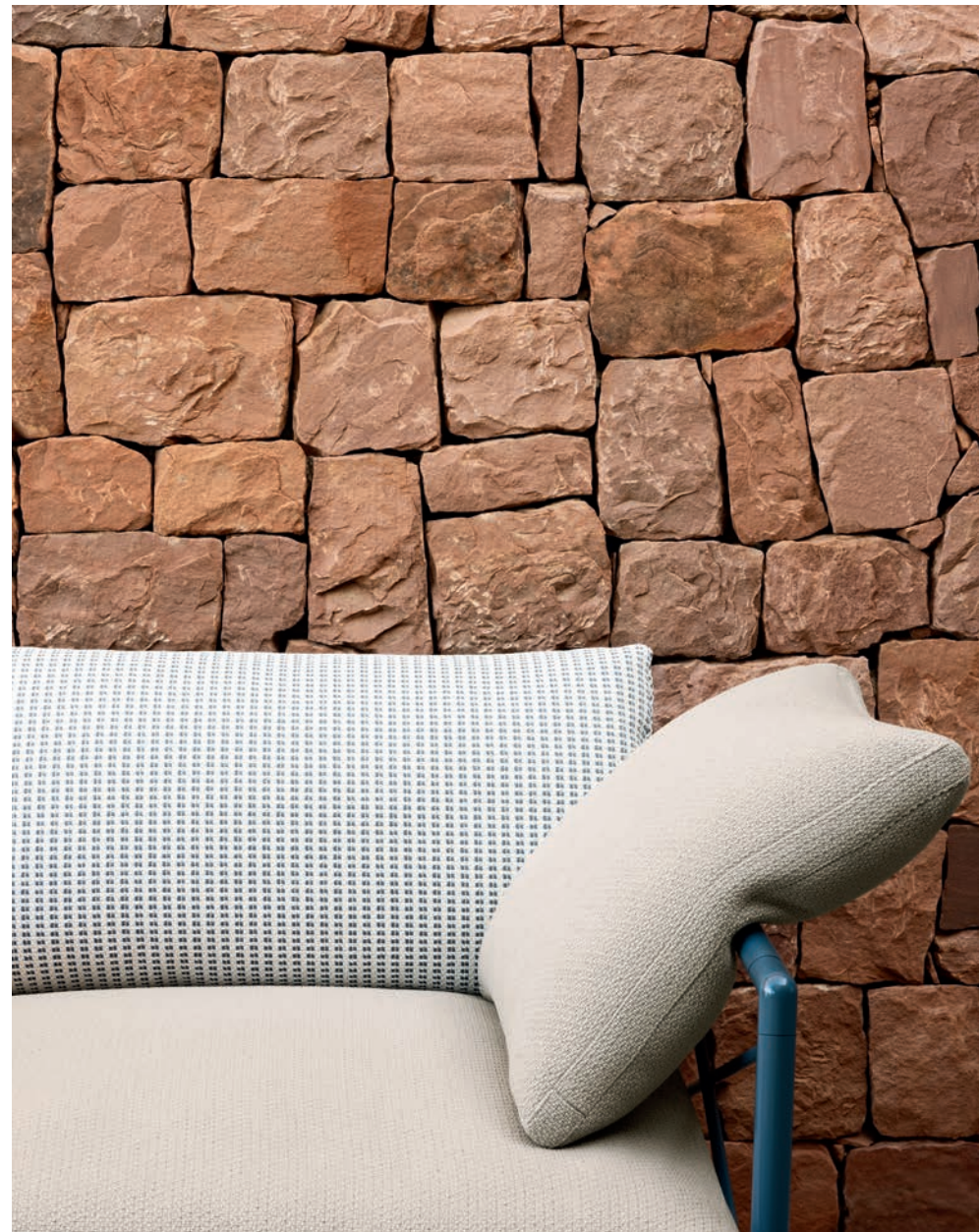

Opposite:  
Nooch, modular sofa • NH95TS • NH95PQ • NH95PQ  
Spool Outdoor, round small table • OS40T

Nella pagina accanto:  
Nooch, divano componibile • NH95TS • NH95PQ • NH95PQ  
Spool Outdoor, tavolino rotondo • OS40T

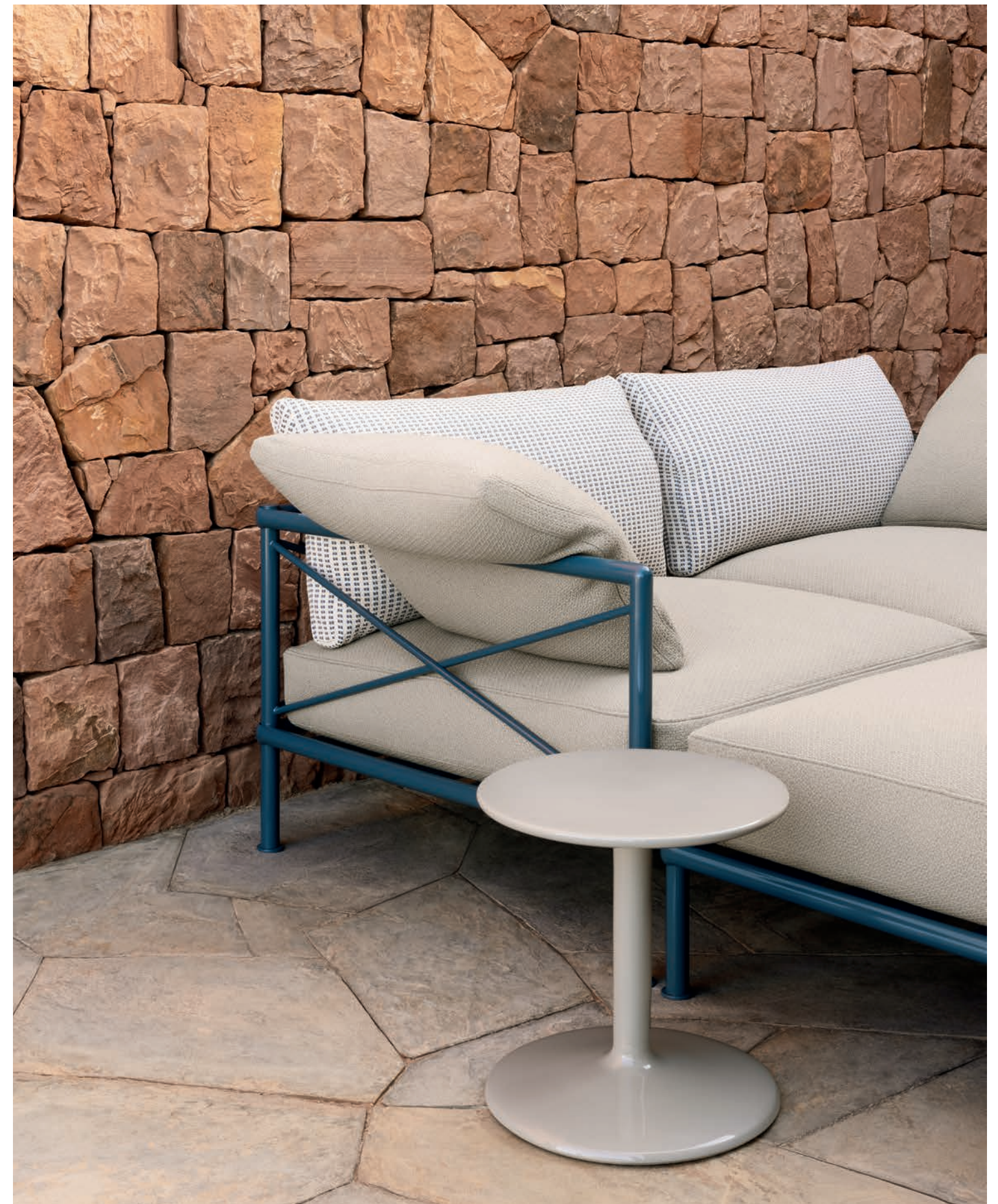



In this page:  
 Borea, round small tables • TBE6 • TBE8

Opposite:  
 Nooch, modular sofa • NH95TS • NH95C • NH95A • NH95C  
 NH3P • NH95C • NH95TD • NH95  
 Borea, round small tables • TBE4 • TBE6 • TBE8

In questa pagina:  
 Borea, tavolini rotondi • TBE6 • TBE8

Nella pagina accanto:  
 Nooch, divano componibile • NH95TS • NH95C • NH95A • NH95C  
 NH3P • NH95C • NH95TD • NH95  
 Borea, tavolini rotondi • TBE4 • TBE6 • TBE8



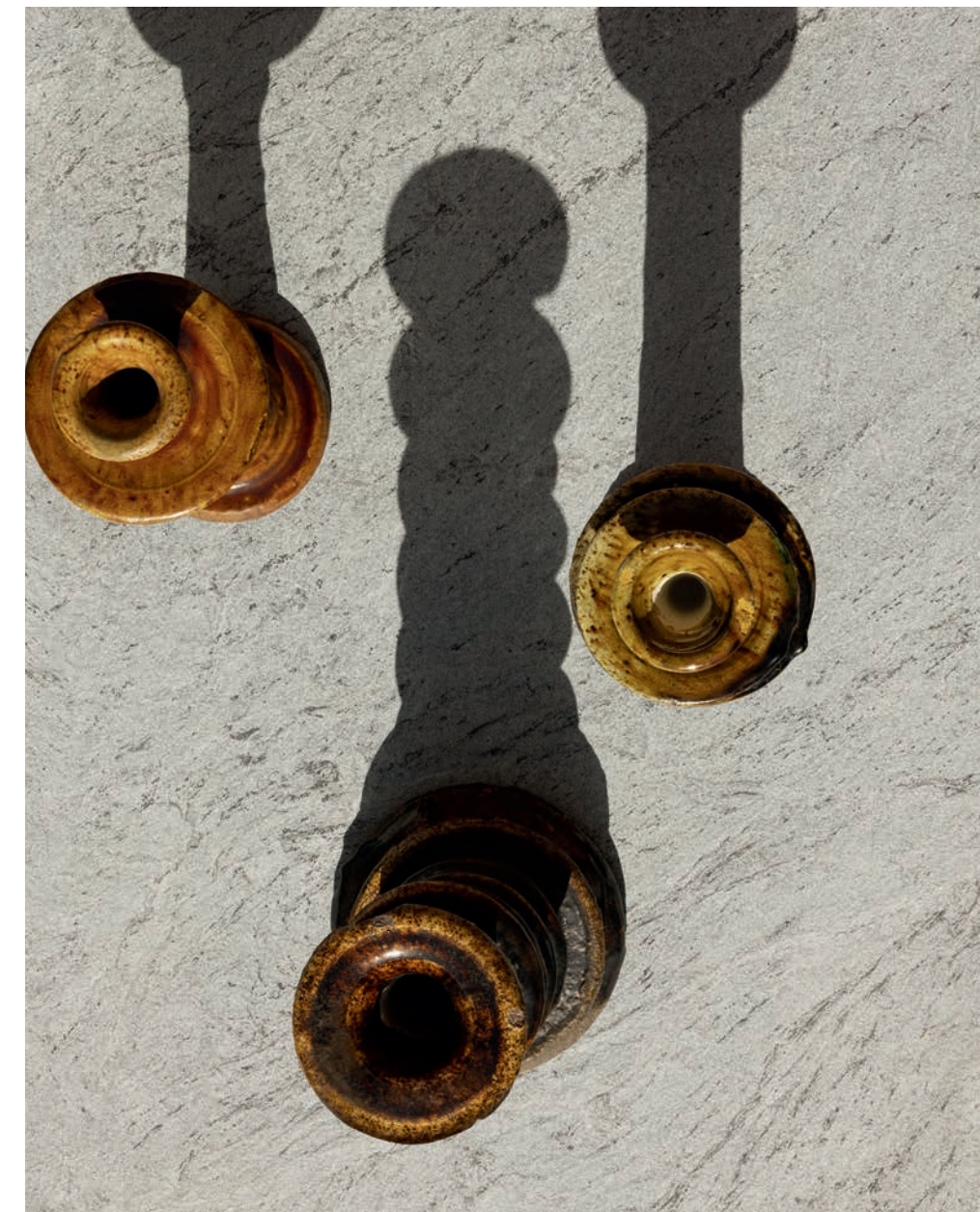

In this page:  
Nooch, modular sofas • NH95C • NH3P

In questa pagina:  
Nooch, divani componibili • NH95C • NH3P



Opposite:  
Nooch, armchair • NH95

Next pages:  
Spool Outdoor, round small tables • OS40T  
Nooch, modular sofa • NH136LS • NH136L  
NH1P\_L • NH95C • NH95C • TNH32 • NH95TD

Nella pagina accanto:  
Nooch, poltrona • NH95

Nelle pagine successive:  
Spool Outdoor, tavolini rotondi • OS40T  
Nooch, divano componibile • NH136LS • NH136L  
NH1P\_L • NH95C • NH95C • TNH32 • NH95TD







Opposite:  
 Nooch, modular sofa • NH136LS • NH136L • NH1P\_L • NH95C • NH95C

In this page:  
 Nooch, modular sofa • NH1P\_L • NH95C

Nella pagina accanto:  
 Nooch, divano componibile • NH136LS • NH136L • NH1P\_L • NH95C • NH95C

In questa pagina:  
 Nooch, divano componibile • NH1P\_L • NH95C



In this page:  
Nooch, low table • TNH136  
Opposite:  
Nooch, low table • TNH136  
Nooch, modular sofa • NH95TD

In questa pagina:  
Nooch, tavolo basso • TNH136  
Nella pagina accanto:  
Nooch, tavolo basso • TNH136  
Nooch, divano componibile • NH95TD



# Cordoba Outdoor

Foster+Partners,  
Industrial Design Studio

“The Cordoba chair is a timeless design. The ergonomics have been finely tuned to provide the highest level of comfort and support. Conceived as an addition to the office or the home, now it also becomes outdoor.”

Mike Holland, Head of Industrial Design

“La sedia Cordoba è un pezzo intramontabile. L'ergonomia è stata messa a punto per fornire il massimo livello di comfort e sostegno. Nata per essere inserita in ufficio o in casa, ora diventa anche outdoor.”

Mike Holland, Head of Industrial Design





Opposite:  
Cordoba Outdoor, armchairs • OCR75

---

Nella pagina accanto:  
Cordoba Outdoor, poltrone • OCR75

---



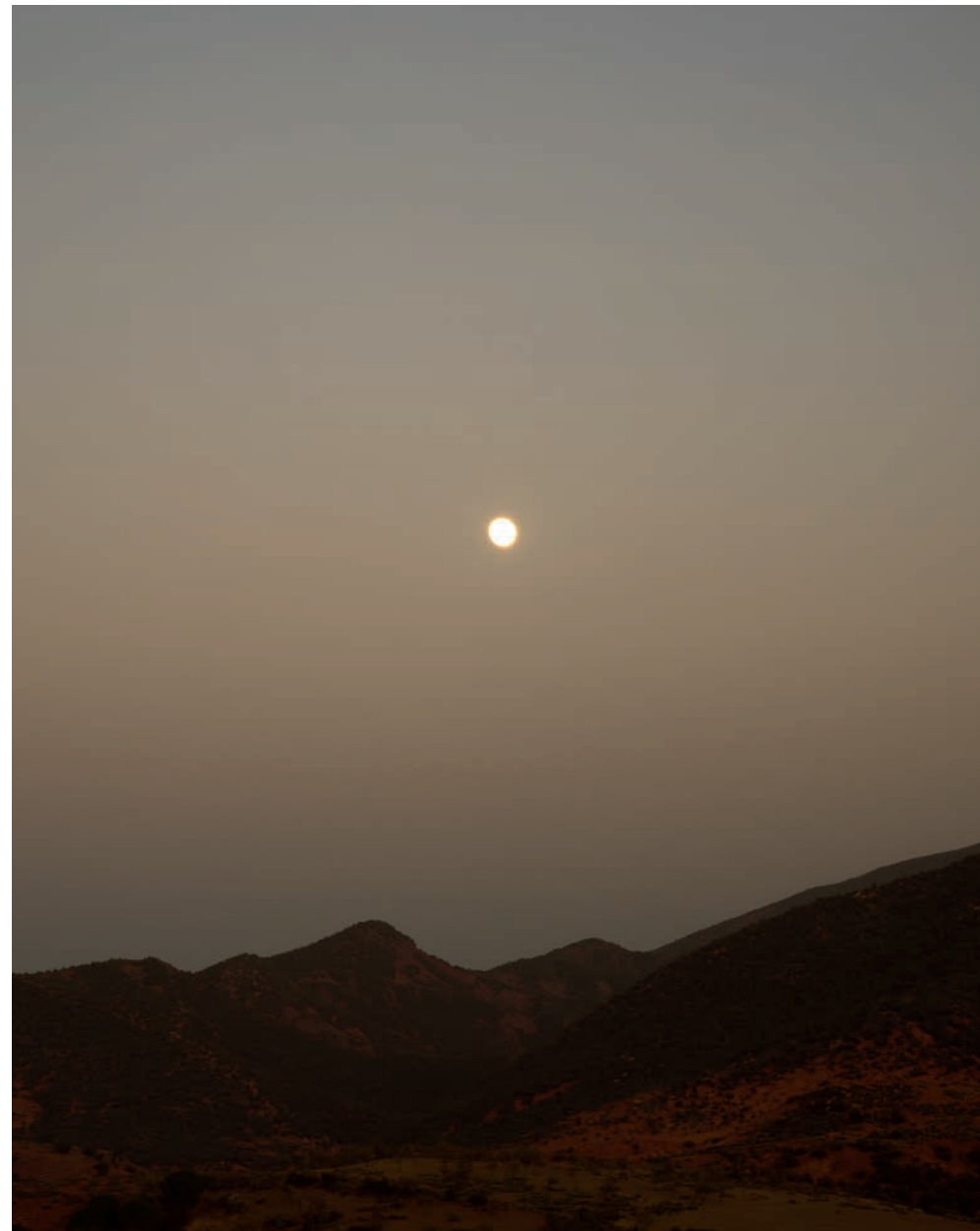

Opposite:  
Cordoba Outdoor, armchair • OCR75

---

Nella pagina accanto:  
Cordoba Outdoor, poltrona • OCR75

---

# Allure O' Outdoor

Monica Armani

“The sculptural shapes of the Allure O' tables meet the magic of glazed ceramic. The ceramic color so present in the common memory finds a new life. Vibrant, reflective surfaces with unique color depth and transparency renew the allure, in name and in fact, of these objects.”

Monica Armani

“Le forme scultoree dei tavoli Allure O' incontrano la magia della ceramica smaltata. Il colore ceramico così presente nella memoria comune trova una nuova vita. Superfici vibranti, riflettenti con profondità di colore e trasparenze uniche rinnovano l'allure di nome e di fatto di questi oggetti”.

Monica Armani





Nella pagina accanto:  
Allure O' Outdoor, table • OA225T\_6G  
Erica, chair • E61SB

---

Opposite:  
Allure O' Outdoor, tavolo • OA225T\_6G  
Erica, sedia • E61SB

---





In this page:

Allure O' Outdoor, table • OA225T\_6G  
Erica, chair • E61SB

---

In questa pagina:

Allure O' Outdoor, tavolo • OA225T\_6G  
Erica, sedia • E61SB

---



These pages:  
[Allure O' Outdoor, table • OA155TQ\\_6G](#)  
[Flair O' Outdoor, chairs • OFL60\\_B](#)

In queste pagine:  
[Allure O' Outdoor, tavolo • OA155TQ\\_6G](#)  
[Flair O' Outdoor, sedie • OFL60\\_B](#)



These pages:  
Allure O' Outdoor, table • OA155TQ\_6G  
Flair O' Outdoor, chair • OFL60\_B

---

In queste pagine:  
Allure O' Outdoor, tavolo • OA155TQ\_6G  
Flair O' Outdoor, sedia • OFL60\_B

---

# Flair O' Outdoor

Monica Armani

“To dress the taut and elegant lines of my Flair O' chair, inspired by the clothes of the 60s, in the outdoor version I thought of a sort of Summer dress with sophisticated transparencies, designing a sort of macro, sinuous and vibrant lace.”

Monica Armani

“Per vestire le linee tese ed eleganti della mia sedia Flair O', ispirate agli abiti degli anni '60, nella versione Outdoor ho pensato a una sorta di abito estivo con delle trasparenze sofisticate, disegnando una sorta di pizzo macro, sinuoso e vibrante”.

Monica Armani





Opposite:  
Flair O' Outdoor, chair • OFL60\_A

---

Nella pagina accanto:  
Flair O' Outdoor, sedia • OFL60\_A

---





Opposite and next page:  
Allure O' Outdoor, table • OA155TQ\_6G  
Flair O' Outdoor, chairs • OFL60\_B

---

Nella pagina accanto:  
Allure O' Outdoor, tavolo • OA155TQ\_6G  
Flair O' Outdoor, sedie • OFL60\_B

---

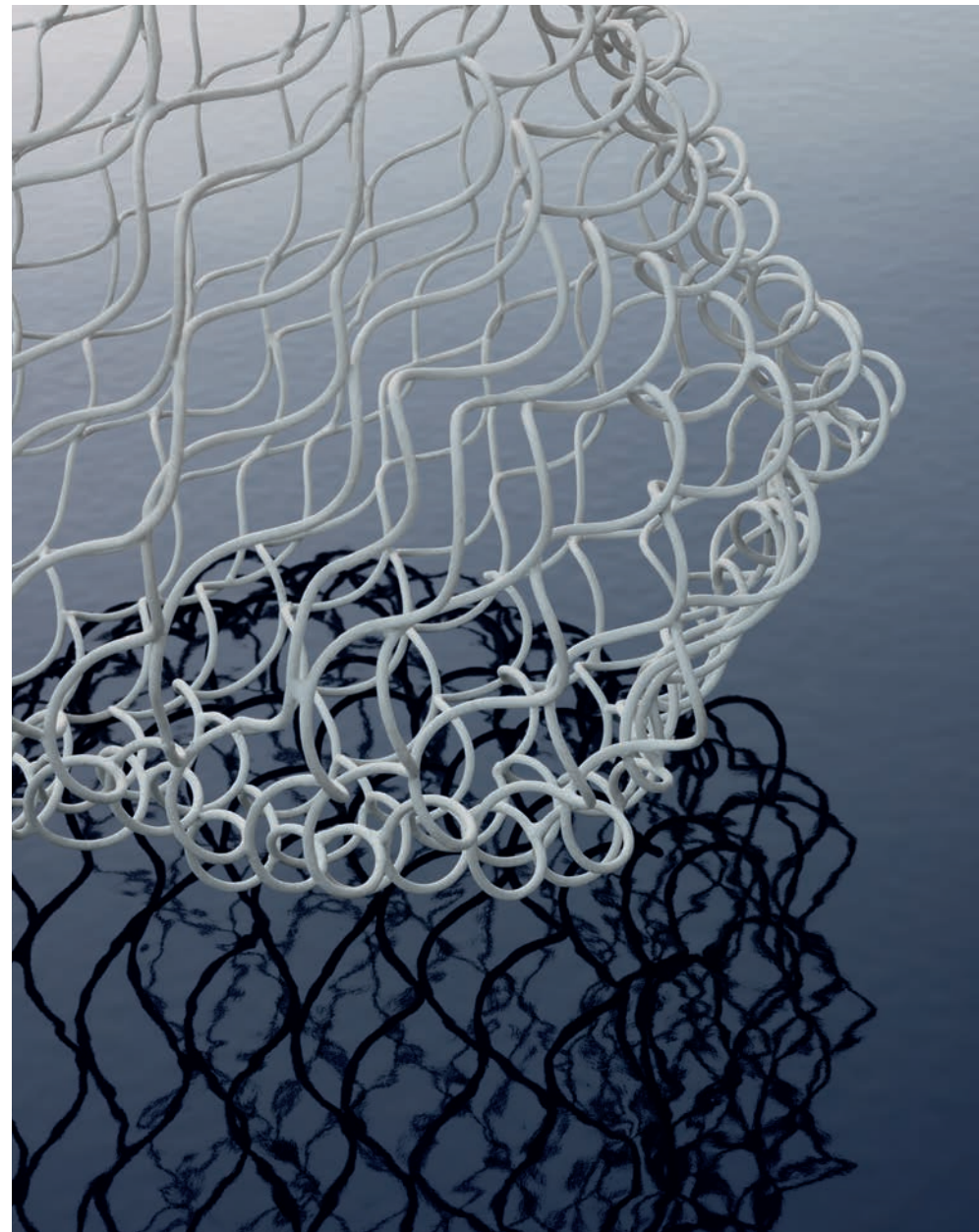

Opposite and next page:  
Allure O' Outdoor, table • OA155TQ\_6G  
Flair O' Outdoor, chair • OFL60\_B

Nella pagina accanto:  
Allure O' Outdoor, tavolo • OA155TQ\_6G  
Flair O' Outdoor, sedia • OFL60\_B





# Pablo Outdoor

Vincent Van Duysen

“My first collection for B&B Italia’s outdoor line develops the Pablo armchair features and adds layers of softness, and the tables are a link to my architectural world“.

Vincent Van Duysen

“Questa mia prima collezione per la linea outdoor di B&B Italia sviluppa nelle sedute le caratteristiche della poltrona Pablo aggiungendovi strati di morbidezza, e si lega al mio mondo architettonico nella parte dei tavoli”.

Vincent Van Duysen





These pages:

Pablo Outdoor, sofas • PBL210  
Pablo Outdoor, armchairs • PBL80  
Pablo Outdoor, ottoman • PBL75P  
Pablo Outdoor, small tables • TPB130 • TPB55

In queste pagine:

Pablo Outdoor, divani • PBL210  
Pablo Outdoor, poltrone • PBL80  
Pablo Outdoor, pouf • PBL75P  
Pablo Outdoor, tavolini • TPB130 • TPB55



These pages:  
Pablo Outdoor, sofas • PBL210  
Pablo Outdoor, armchairs • PBL80

Pablo Outdoor, small table • TPB130  
Kyra, carpet • TY200

In queste pagine:  
Pablo Outdoor, divani • PBL210  
Pablo Outdoor, poltrone • PBL80

Pablo Outdoor, tavolino • TPB130  
Kyra, tappeto • TY200



Opposite and next pages:  
Pablo Outdoor, small tables • TPB130 • TPB55

Nella pagina accanto e nelle successive:  
Pablo Outdoor, tavolini • TPB130 • TPB55

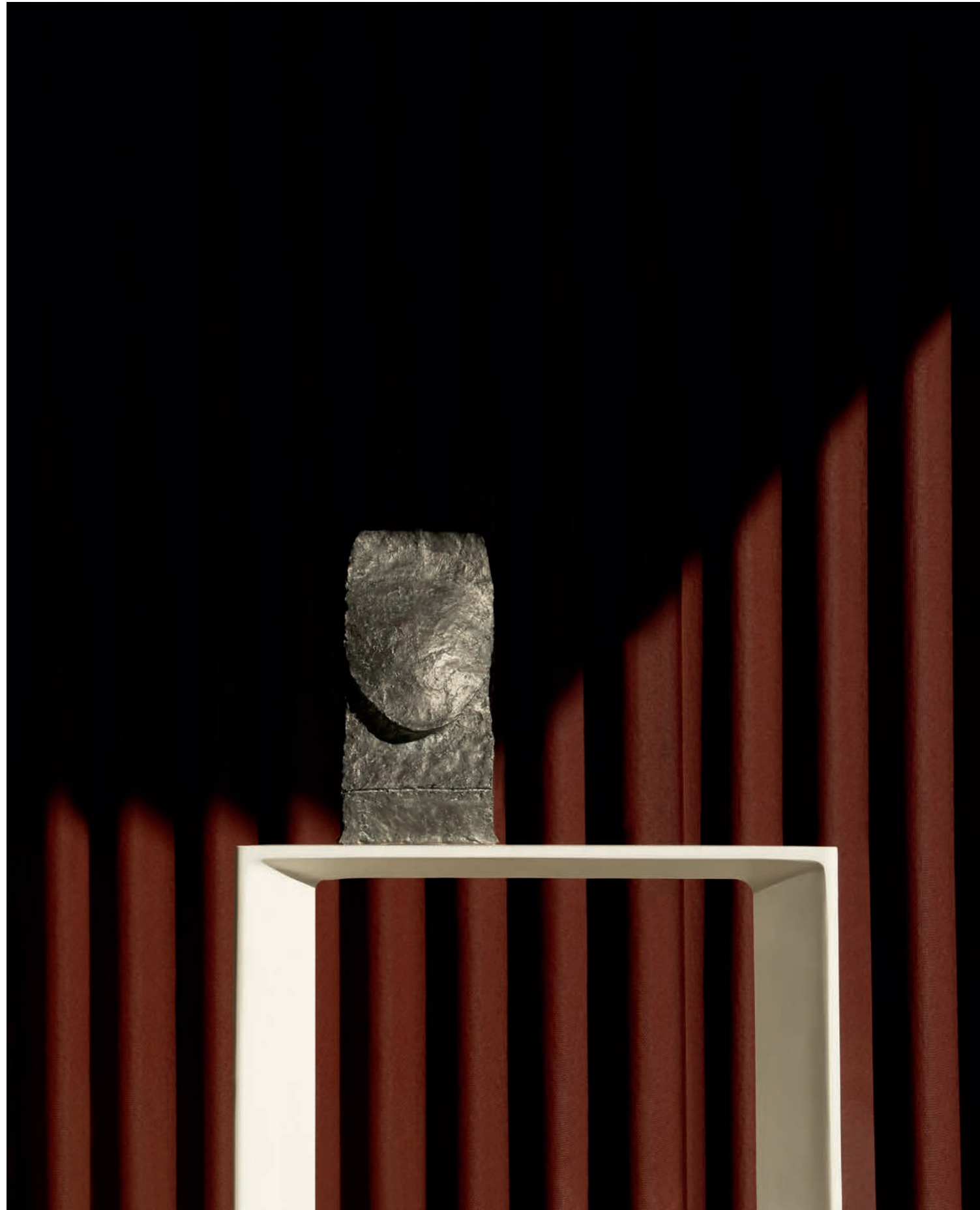



Opposite:  
 Pablo Outdoor, sofa • PBL210  
 Borea, round small table • TBE4

This page:  
 Pablo Outdoor, sofa • PBL210

Nella pagina accanto:  
 Pablo Outdoor, divano • PBL210  
 Borea, tavolino rotondo • TBE4

In questa pagina:  
 Pablo Outdoor, divano • PBL210



These pages:  
[Pablo Outdoor, lounge armchairs • PBL82L](#)

In queste pagine:  
[Pablo Outdoor, poltrone lounge • PBL82L](#)



Opposite:  
Pablo Outdoor, lounge armchairs • PBL82L  
Borea, round small table • TBE4

Next pages:  
Pablo Outdoor, lounge armchair • PBL82L  
Spool Outdoor, small table • OS40T

Nella pagina accanto:  
Pablo Outdoor, poltrone lounge • PBL82L  
Borea, tavolino rotondo • TBE4

Nelle pagine successive:  
Pablo Outdoor, poltrona • BE150L • BE210L  
Spool Outdoor, tavolino • OS40T





# Borea

Piero Lissoni

“Borea is an airplane. It is an airplane that has landed, an airplane of 2020 but with a technological soul that perhaps comes from another century.”  
Piero Lissoni

“Borea è un aeroplano. È un aeroplano che è atterrato, un aeroplano del 2020 ma con un'anima tecnologica che forse arriva da un altro secolo.”  
Piero Lissoni





These pages:  
 Borea, sofas • BE243  
 Borea, armchairs • BE108

Borea, rectangular low tables • TBE121  
 Borea, round small tables • TBE4 - TBE8  
 Piet, carpet • TPI300

In queste pagine:  
 Borea, divani • BE243  
 Borea, poltrone • BE108

Borea, tavoli bassi rettangolari • TBE121  
 Borea, tavolini rotondi • TBE4 - TBE8  
 Piet, carpet • TPI300



Opposite:  
 Borea, armchairs • BE108  
 Borea, rectangular low table • TBE121

Borea, round small table • TBE4  
 Piet, carpet • TPI300

Nella pagina accanto:  
 Borea, poltrone • BE108  
 Borea, tavolo basso rettangolare • TBE121

Borea, tavolino rotondo • TBE4  
 Piet, tappeto • TPI300



These pages :  
Borea, sofa • BE175  
Borea, small armchairs • BE69PB  
Borea, round small tables • TBE4 • TBE8

In queste pagine:  
Borea, divano • BE175  
Borea, poltroncine • BE69PB  
Borea, tavolini rotondi • TBE4 • TBE8

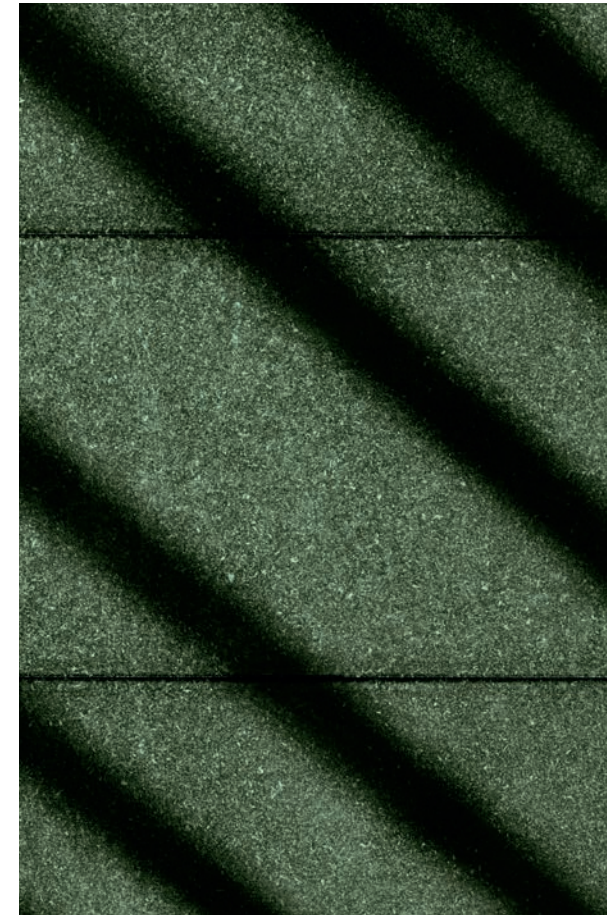

These pages:  
Borea, round small tables • TBES • TBE4  
Borea, rectangular low table • TBE121

In queste pagine:  
Borea, tavolini rotondi • TBES • TBE4  
Borea, tavolo basso rettangolare • TBE121





Previous pages:  
Borea, oval sunbed • BE210L  
Borea, round small table • TBE8

Opposite:  
Borea, oval sunbeds • BE150L • BE210L  
Borea, round small tables • TBE4 • TBE6 • TBE8

Nelle pagine precedenti:  
Borea, lettino ovale • BE210L  
Borea, tavolino rotondo • TBE8

Nella pagina accanto:  
Borea, lettini ovali • BE150L • BE210L  
Borea, tavolini rotondi • TBE4 • TBE6 • TBE8





These pages:  
Borea, oval sunbed • BE210L

In queste pagine  
Borea, lettino ovale • BE210L

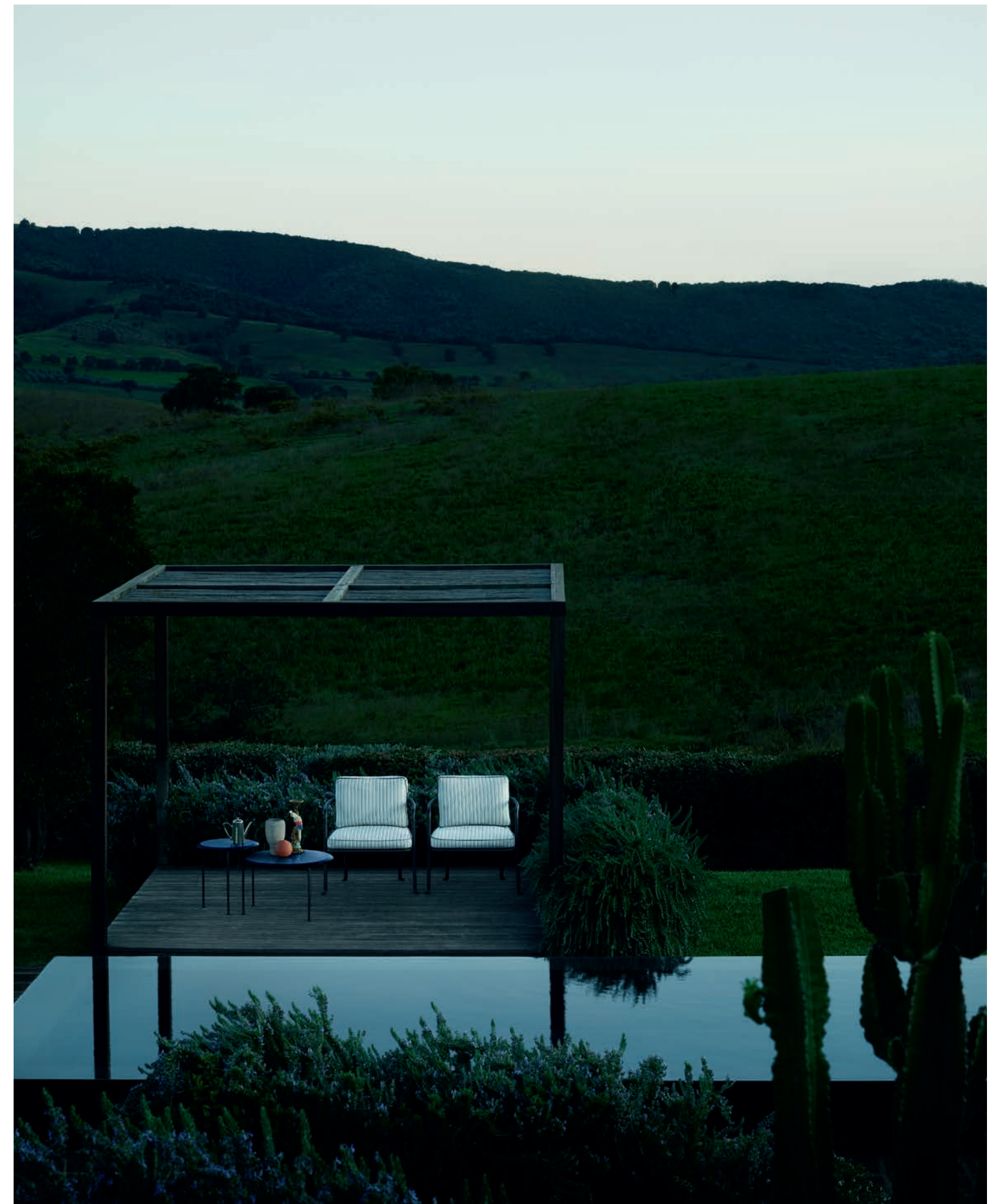
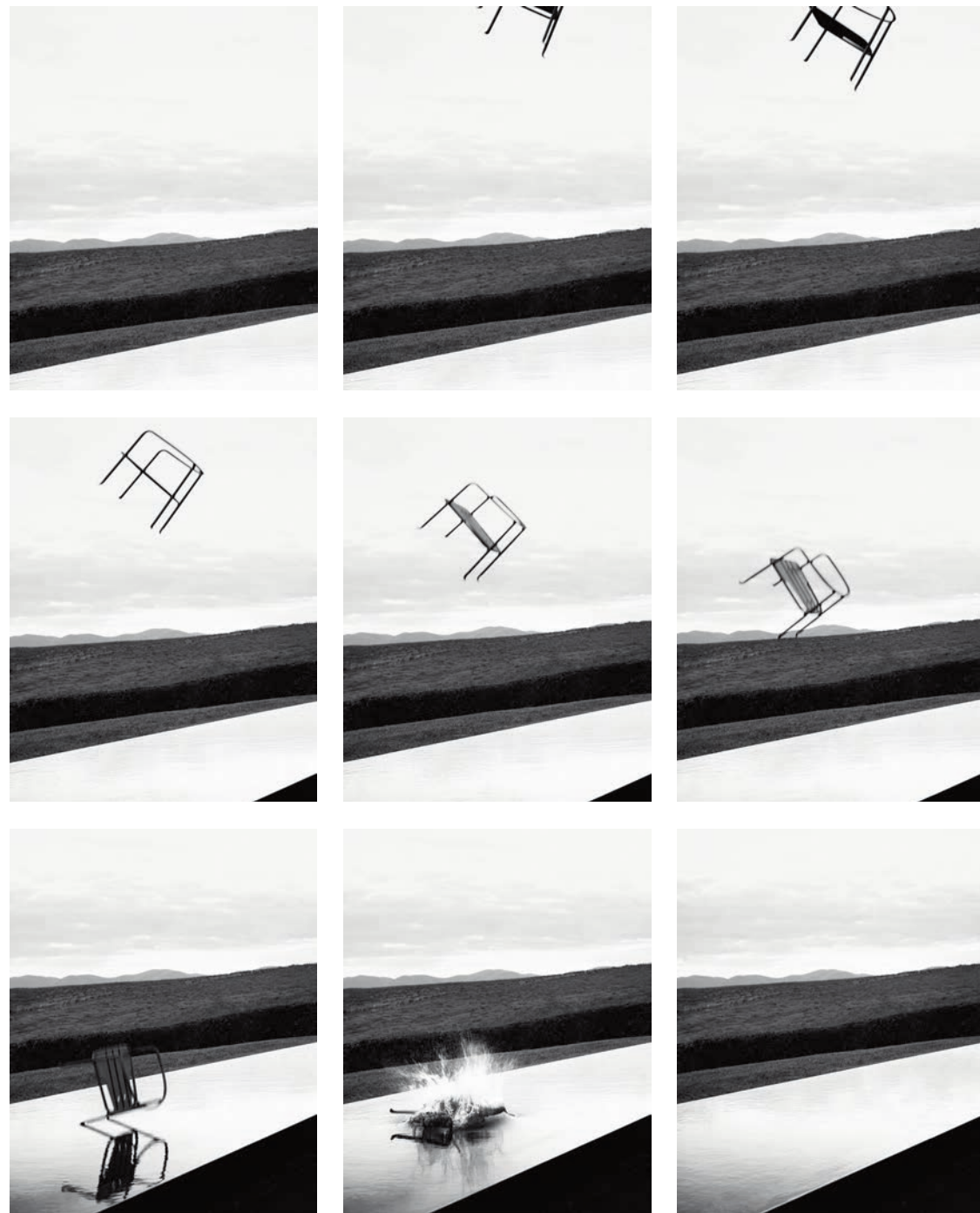

These pages:  
 Borea, small armchairs • BE69PB  
 Borea, round small tables • TBE4 • TBE6

In queste pagine:  
 Borea, poltroncine • BE69PB  
 Borea, tavolini rotondi • TBE4 • TBE6



In these pages:  
Borea, table • TBE285  
Borea, chairs • BE69PA

In queste pagine:  
Borea, tavolo • TBE285  
Borea, sedie • BE69PA

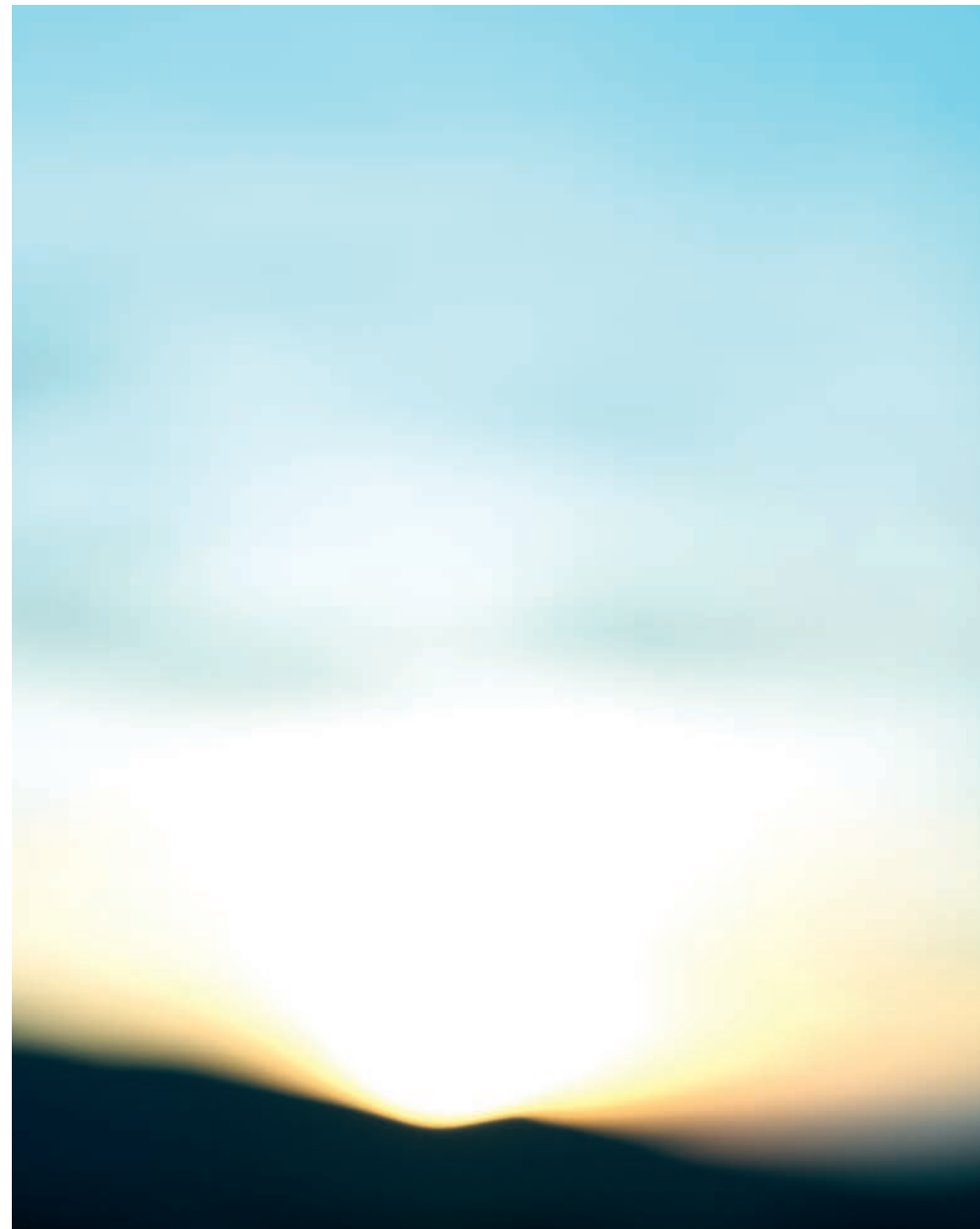

Opposite and next pages:  
Borea, table • TBE285  
Borea, chairs • BE69PA

Nella pagina accanto e nelle successive:  
Borea, tavolo • TBE285  
Borea, sedie • BE69PA





# Ayana

Naoto Fukasawa



Minimalist and innovative, Ayana collection sees wood as the protagonist with a pleasant oriental touch.

Minimalista e innovativa, la collezione Ayana vede come protagonista il legno con un piacevole tocco orientale.



These pages:  
Ayana, sofa • AY263  
Ayana, armchairs • AY86P

Ayana, low table • TAY180  
Colosseo Outdoor, service elements • OCL40T • OCL45T  
Kyra, carpets • TY200

In queste pagine:  
Ayana, divano • AY263  
Ayana, poltrone • AY86P

Ayana, tavolo basso • TAY180  
Colosseo Outdoor, elementi di servizio • OCL40T • OCL45T  
Kyra, tappeti • TY200

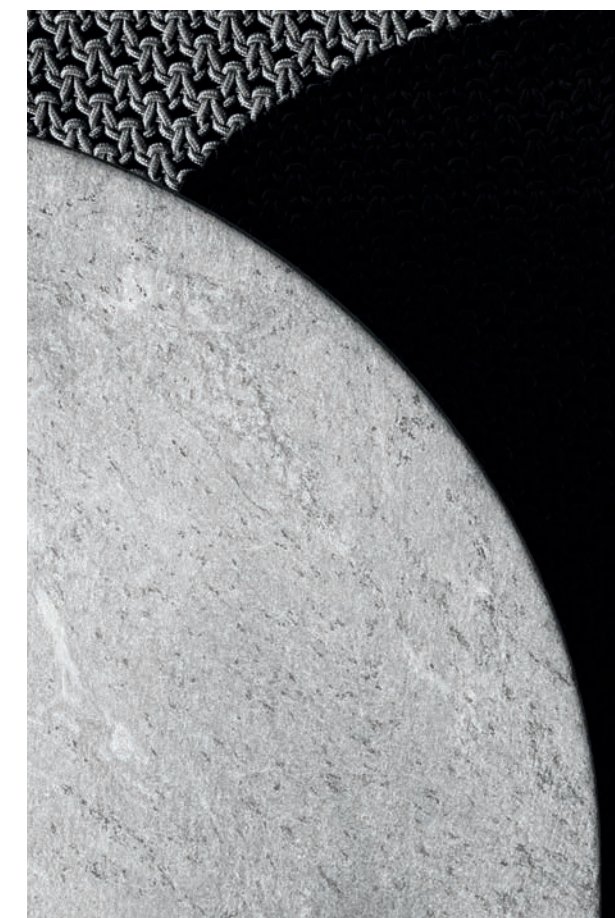
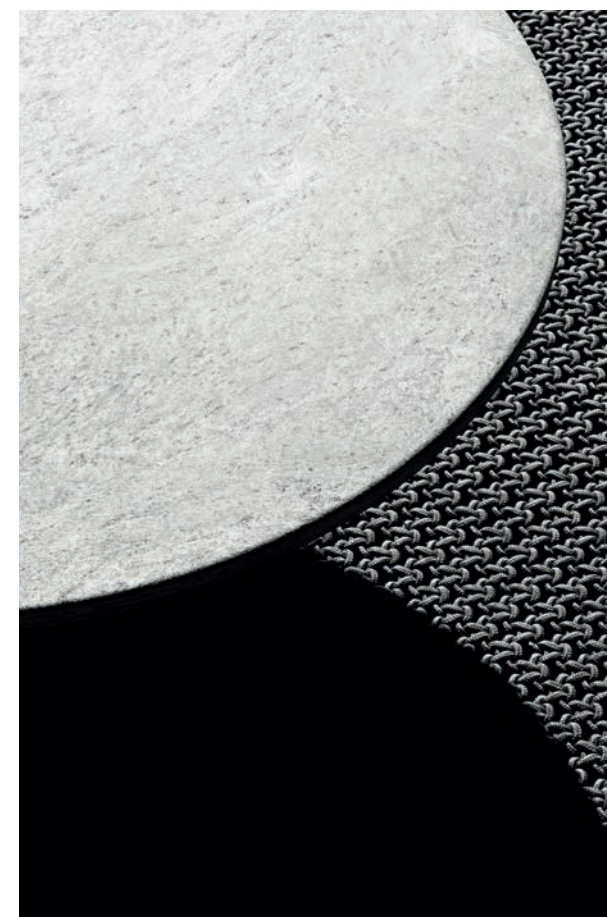

Opposite:  
 Ayana, sofa • AY263  
 Ayana, low table • TAY180

Colosseo Outdoor, service element • OCL40T  
 Kyra, carpets • TY200

Nella pagina accanto:  
 Ayana, divano • AY263  
 Ayana, tavolo basso • TAY180

Colosseo Outdoor, elemento di servizio • OCL40T  
 Kyra, tappeti • TY200





These pages:  
Ayana, sofa • AY263  
Ayana, armchairs • AY86P  
Ayana, low table • TAY180  
Kyra, carpets • TY200

In queste pagine:  
Ayana, divano • AY263  
Ayana, poltrone • AY86P  
Ayana, tavolo basso • TAY180  
Kyra, tappeti • TY200



These pages:  
 Ayana, sofas • AY210  
 Ayana, armchair • AY86P

Ayana, low table • TAY180  
 Colosseo Outdoor, service elements • OCL40T  
 Kyra, carpets • TY200

In queste pagine:  
 Ayana, divani • AY210  
 Ayana, poltrona • AY86P

Ayana, tavolo basso • TAY180  
 Colosseo Outdoor, elemento di servizio • OCL40T  
 Kyra, tappeti • TY200



Opposite:  
 Ayana, table • TAY230  
 Ayana, chairs • AY58S

Hospes, ottoman • HE2  
 Kyra, carpet • TY200

Nella pagina accanto:  
 Ayana, tavolo • TAY230  
 Ayana, sedie • AY58S

Hospes, pouf • HE2  
 Kyra, tappeto • TY200

# Hybrid

Antonio Citterio



Hybrid is an innovative system of modular seating elements that represents a real link between the inside and the outside of the house.

Hybrid è un sistema di sedute modulare che rappresenta il vero anello di congiunzione tra l'interno e l'esterno della casa.



These pages:  
 Hybrid, chaise longue • HY134L\_2 • HY200L  
 Hybrid, modular sofa • HY134L\_2 • HY134L

Gio, low table • TGO18  
 Fat-Fat Outdoor, small tables • OTF62G • OTF92G  
 Tramae, ottomans • TRM60P • TRM90P

Twist, carpets • TW200

In queste pagine:  
 Hybrid, chaise longue • HY134L\_2 • HY200L  
 Hybrid, divano componibile • HY134L\_2 • HY134L

Gio, tavolo basso • TGO18  
 Fat-Fat Outdoor, tavolini • OTF62G • OTF92G  
 Tramae, pouf • TRM60P • TRM90P

Twist, tappeti • TW200



These pages:  
 Hybrid, chaise longue • HY134L\_2 • HY200L  
 Gio, low table • TGO18 Gio, small table • TGO6

Gio, armchairs • G064  
 Tramae, ottoman • TRM60P  
 Twist, carpet • TW200

In queste pagine:  
 Hybrid, chaise longue • HY134L\_2 • HY200L  
 Gio, tavolo basso • TGO18 Gio, tavolino • TGO6

Gio, poltrone • G064  
 Tramae, pouf • TRM60P  
 Twist, tappeto • TW200



Opposite:  
 Hybrid, sofa • 9HY222  
 Tramae, ottoman • TRM60P

Fat-Fat Outdoor, small tables • OTF62G • OTF92G  
 Kyra, carpet • TY200

Nella pagina accanto:  
 Hybrid, divano • 9HY222  
 Tramae, pouf • TRM60P

Fat-Fat Outdoor, tavolini • OTF62G • OTF92G  
 Kyra, tappeto • TY200



These pages:  
 Hybrid, sofas • 9HY266C • HY266C  
 Tramae, ottomans • TRM47P • TRM60P

Canasta, low tables • TCN15  
 Canasta '13, small table • TCNC3  
 Kyra, carpet • TY200

In queste pagine:  
 Hybrid, divani • 9HY266C • HY266C  
 Tramae, pouf • TRM47P • TRM60P

Canasta, tavoli bassi • TCN15  
 Canasta '13, tavolino • TCNC3  
 Kyra, tappeto • TY200





These pages:  
 Hybrid, modular sofa • 9HY178PA • 9HY200T\_1  
 Hybrid, ottoman • HY178P  
 Erica '19, small armchairs • NES0P  
 Mirto Outdoor, console • TMO162\_6  
 Mirto Outdoor, low tables • TMO162\_4  
 Frank Outdoor, ottoman • OF58P  
 Kyra, carpet • TY200

In queste pagine:  
 Hybrid, divano componibile • 9HY178PA • 9HY200T\_1  
 Hybrid, pouf • HY178P  
 Erica '19, poltroncine • NES0P  
 Mirto Outdoor, console • TMO162\_6  
 Mirto Outdoor, tavoli bassi • TMO162\_4  
 Frank Outdoor, pouf • OF58P  
 Kyra, tappeto • TY200

# Oh, it rains!

Philippe Starck

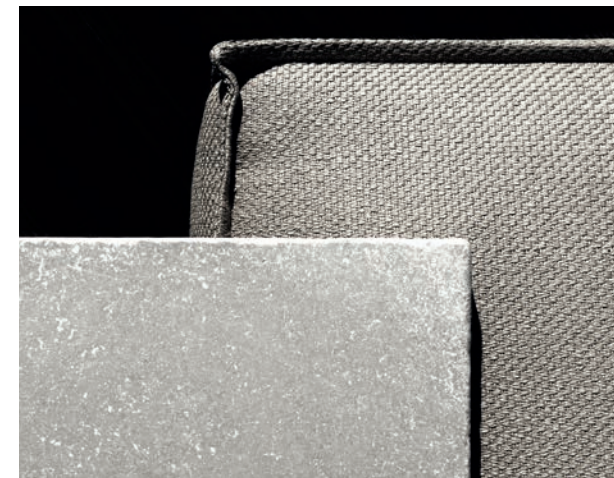

**Innovation, technology, high quality and comfort are the key characteristics of this visionary collection.**

Innovazione, tecnologia, alta qualità e comfort sono le caratteristiche principali di questa collezione visionaria.

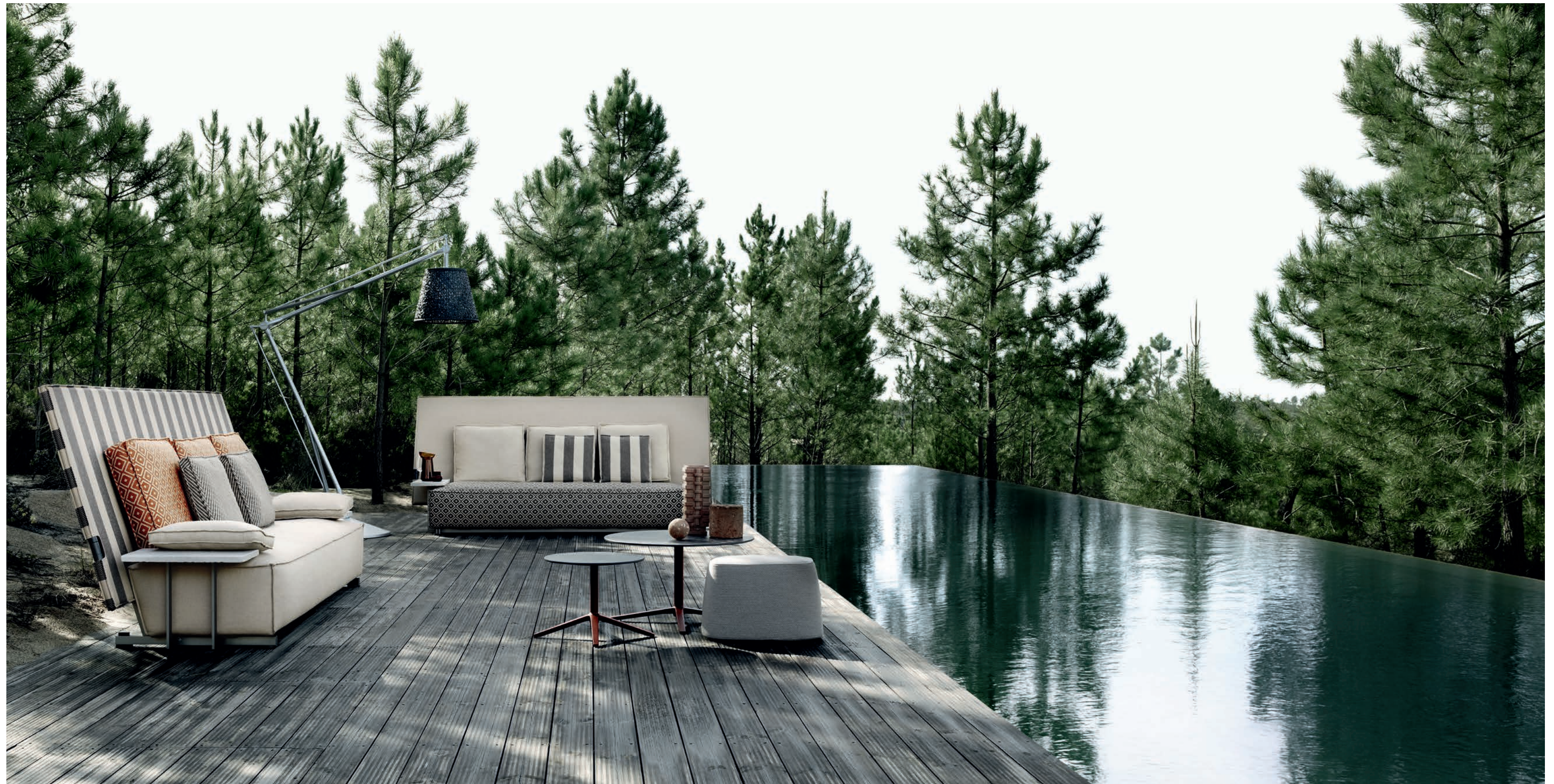

These pages:  
Oh, it rains!, sofas • OH280 • TOH1  
Frank Outdoor, ottoman • OF58P

\*Cosmos Outdoor, small tables  
\*B&B Italia archive

In queste pagine:  
Oh, it rains!, divani • OH280 • TOH1  
Frank Outdoor, pouf • OF58P

\*Cosmos Outdoor, tavolini  
\*Archivio B&B Italia



This page:  
Oh, it rains!, armchair • OH140PS • TOH1

In questa pagina:  
Oh, it rains!, poltrona • OH140PS • TOH1

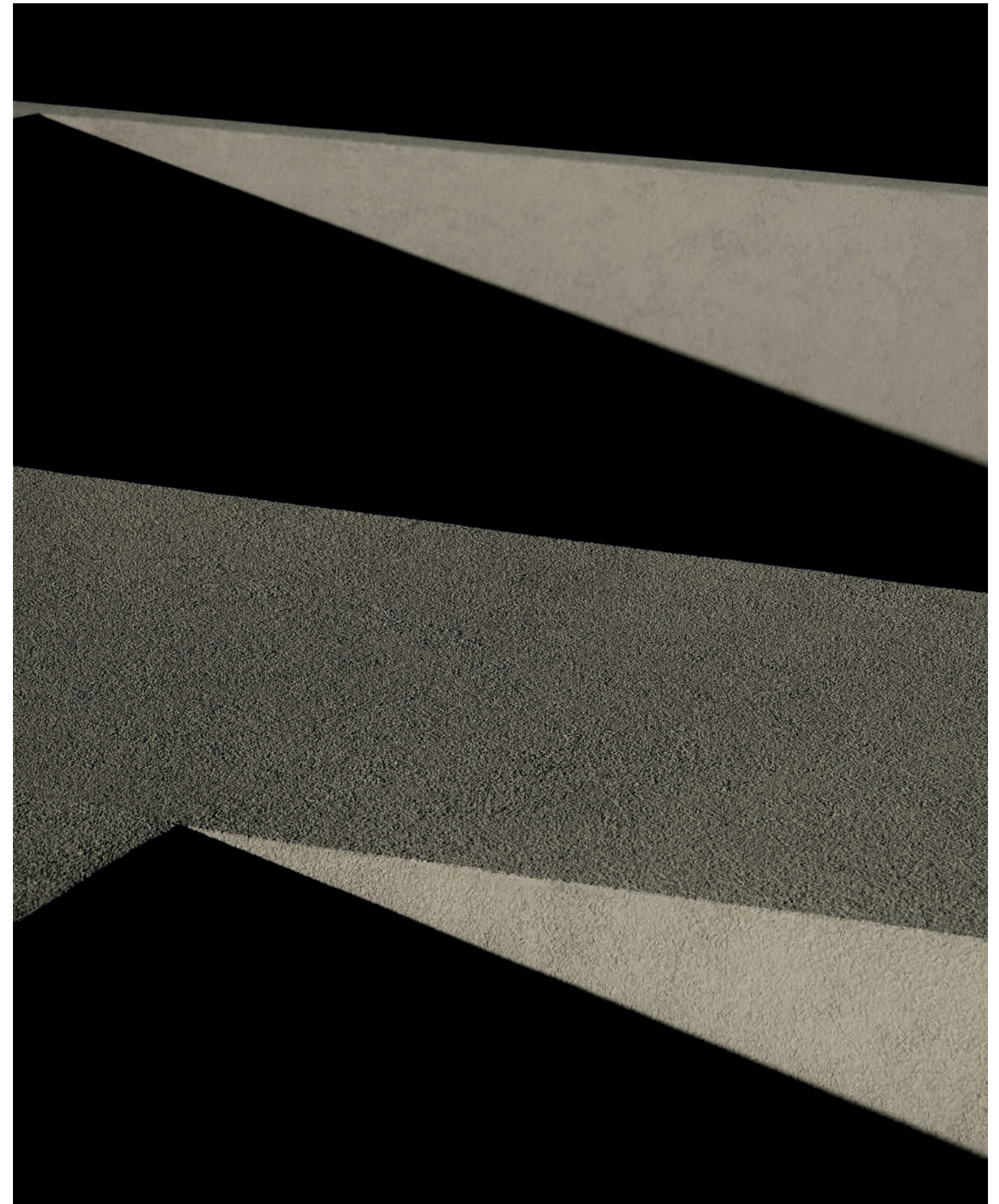





Previous pages:  
 Oh, it rains!, sofas • OH280 • TOH1  
 \*Cosmos Outdoor, small tables  
 \*B&B Italia archive

Opposite:  
 Oh, it rains!, sofa • OH280 • TOH1

Nelle pagine precedenti:  
 Oh, it rains!, divani • OH280 • TOH1  
 \*Cosmos Outdoor, small tables  
 \*Archivio B&B Italia

Nella pagina accanto:  
 Oh, it rains!, divano • OH280 • TOH1



# Ribes

Antonio Citterio



The starting point is a futon base with flexible glass-fibre slats resting on an aluminium frame.

Il punto di partenza è una base "futon" con doghe flessibili in fibra di vetro, appoggiate su una struttura in alluminio.





These pages:  
 Ribes, modular sofa • RBR141LB\_2 • RBR190PA  
 Erica '19, small armchairs • NE80P

Frank Outdoor, ottomans • OF58P  
 Canasta, low table • TCN15  
 Canasta '13, small tables • TCNC3

Kyra, carpets • TY200  
 \*Karam, floor basket  
 \*B&B Italia archive

In queste pagine:  
 Ribes, divano componibile • RBR141LB\_2 • RBR190PA  
 Erica '19, poltroncine • NE80P

Frank Outdoor, pouf • OF58P  
 Canasta, tavolo basso • TCN15  
 Canasta '13, tavolini • TCNC3

Kyra, tappeti • TY200  
 \*Karam, ceste da terra  
 \*Archivio B&B Italia



Opposite:  
Ribes, modular sofa • RB141LB\_2 • RB141LB\_2  
Erica '19, small armchair • NES0P

Canasta, low table • TCN15  
Canasta '13, small table • TCNC3  
Kyra, carpets • TY200

Nella pagina accanto:  
Ribes, divano componibile • RB141LB\_2 • RB141LB\_2  
Erica '19, poltroncina • NES0P

Canasta, tavolo basso • TCN15  
Canasta '13, tavolino • TCNC3  
Kyra, tappeti • TY200





These pages:

Ribes, modular sofa • RBR145LB\_1  
Mirto Outdoor, folding small armchairs • MI59N

Fat-Fat Outdoor, trays • OF42V • OF62V  
Kyra, carpets • TY200  
\*Karam, floor basket \*B&B Italia archive

Mirto Outdoor, table • TM0162Q  
Erica '19, stackable chairs • NE61S\_I  
Frank Outdoor, ottoman • OF58P

In queste pagine:

Ribes, divano componibile • RBR145LB\_1  
Mirto Outdoor, poltroncine pieghevoli • MI59N

Fat-Fat Outdoor, vassoi • OF42V • OF62V  
Kyra, tappeti • TY200  
\*Karam, floor basket \*Archivio B&B Italia

Mirto Outdoor, tavolo • TM0162Q  
Erica '19, sedie impilabili • NE61S\_I  
Frank Outdoor, pouf • OF58P



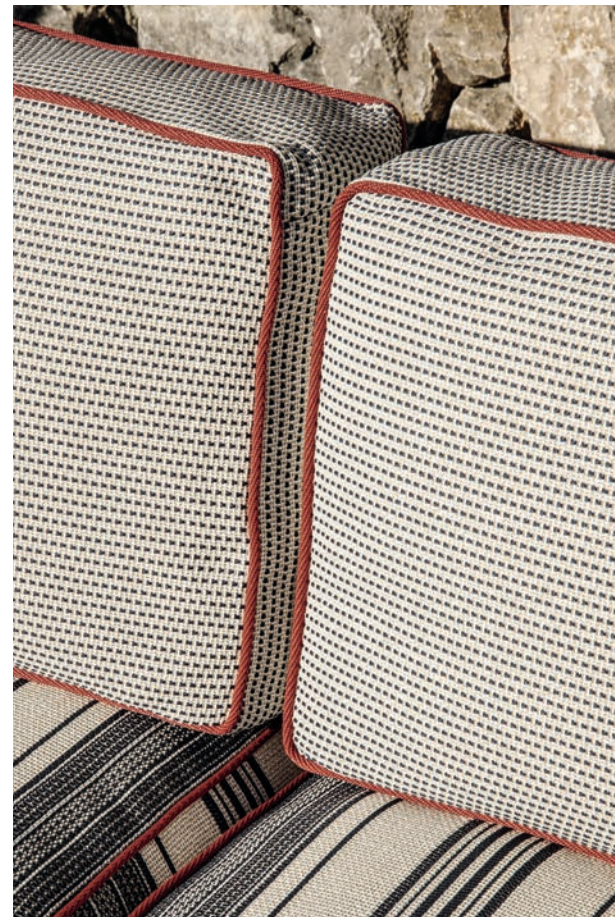

Previous and these pages:  
 Ribes, modular sofa • RBR141LB\_3 • RB201T\_3  
 Mirto Outdoor, folding small armchair • MI59N

Frank Outdoor, ottoman • OF58P  
 Fat-Fat Outdoor, small table • OTF62A  
 Fat-Fat Outdoor, tray • OF42V

Kyra, carpets • TY200  
 \*Karam, floor basket  
 \*B&B Italia archive

In queste pagine e nelle precedenti:  
 Ribes, divano componibile • RBR141LB\_3 • RB201T\_3  
 Mirto Outdoor, poltroncina pieghevole • MI59N

Frank Outdoor, pouf • OF58P  
 Fat-Fat Outdoor, tavolino • OTF62A  
 Fat-Fat Outdoor, vassoio • OF42V

Kyra, tappeti • TY200  
 \*Karam, ceste da terra  
 \*Archivio B&B Italia





These pages:  
Ribes, modular sofa • RB201T\_4 • RB201T\_3  
Erica '19, small armchairs • NESOP

Fat-Fat Outdoor, small tables • OTF92G • OTF62 • OTF62A  
Kyra, carpets • TY200

In queste pagine:  
Ribes, divano componibile • RB201T\_4 • RB201T\_3  
Erica '19, poltroncine • NESOP

Fat-Fat Outdoor, tavolini • OTF92G • OTF62 • OTF62A  
Kyra, tappeti • TY200



Nella pagina accanto e in questa pagina:  
 Ribes, chaise longue • RB130PQ\_1  
 Twist, tappeto • TW200

Nelle pagine successive:  
 Ribes, chaise longue • RB130PQ\_1  
 Twist, tappeto • TW200

\*Cosmos Outdoor, tavolino  
 \*Archivio B&B Italia

Opposite and this page:  
 Ribes, chaise longue • RB130PQ\_1  
 Twist, carpet • TW200

Next pages:  
 Ribes, chaise longue • RB130PQ\_1  
 Twist, carpet • TW200

\*Cosmos Outdoor, small table  
 \*B&B Italia archive





# Erica Erica '19

Antonio Citterio

The lightness and the design of the elements make them ideal for both public and residential settings, featuring seat and back cushions for ergonomic comfort together with strength for outdoor use. A real invitation to relax.

La leggerezza e il disegno degli elementi ne suggeriscono l'utilizzo sia in spazi pubblici che residenziali, rispettando criteri di ergonomia e adattabilità ambientale.  
Un vero e proprio invito al relax.





These pages:  
Erica '19, sofa • NE153  
Erica '19, small armchairs • NE80P

Fat-Fat Outdoor, small tables • OFT62 • OFT42

In queste pagine:  
Erica '19, divano • NE153  
Erica '19, poltroncine • NE80P

Fat-Fat Outdoor, tavolini • OFT62 • OFT42



Opposite:  
Erica '19, sofa • 9NE170  
Fat-Fat Outdoor, small tables • OFT62 • OFT42

Kyra, carpets • TY200

Nella pagina accanto:  
Erica '19, divano • 9NE170  
Fat-Fat Outdoor, tavolini • OFT62 • OFT42

Kyra, tappeti • TY200



These pages:  
Erica '19, sofa • 9NE170  
Erica '19, small armchairs • NE80P  
Fat-Fat Outdoor, small tables • OFT62 • OFT42  
Kyra, carpets • TY200

In queste pagine:  
Erica '19, divano • 9NE170  
Erica '19, poltroncine • NE80P  
Fat-Fat Outdoor, tavolini • OFT62 • OFT42  
Kyra, tappeti • TY200

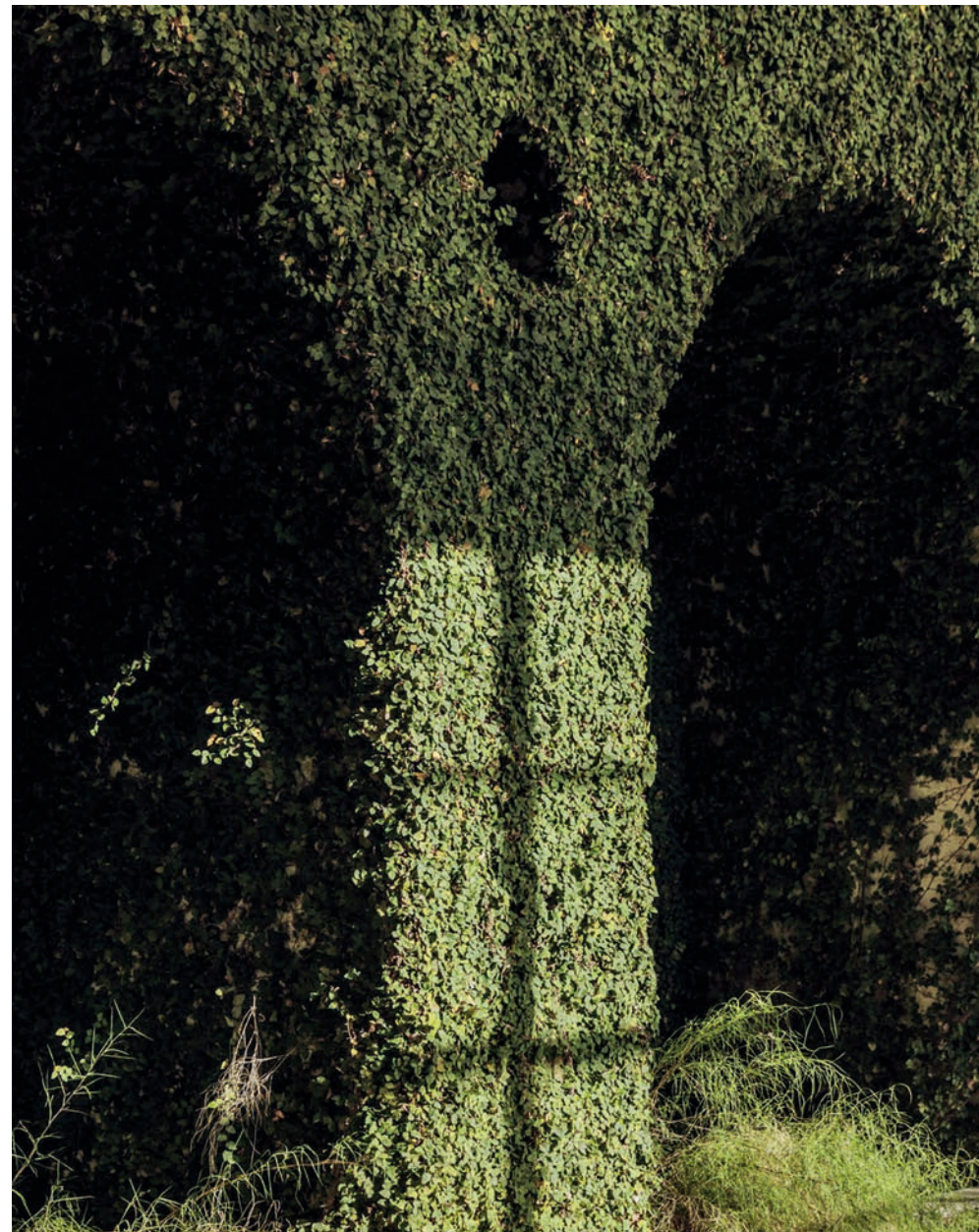

Opposite:  
Erica '19, stackable chairs • NE61S\_I  
Mirto Outdoor, table • TMO222

Kyra, carpets • TY200

Nella pagina accanto:  
Erica '19, sedie impilabili • NE61S\_I  
Mirto Outdoor, tavolo • TMO222

Kyra, tappeti • TY200



These pages:  
Erica, sofa • E216  
Erica, armchairs • E90P

Mirto Outdoor, low table • MI180\_4G  
Mirto Outdoor, console • MI200\_6G  
Twist, carpets • TW300

In queste pagine:  
Erica, divano • E216  
Erica, poltrone • E90P

Mirto Outdoor, tavolo basso • MI180\_4G  
Mirto Outdoor, console • MI200\_6G  
Twist, tappeti • TW300



Opposite:  
Erica, sofa • E170  
Erica, armchair • E90P

Pushpam, small table • TF100RB  
Twist, carpets • TW300

This page:  
Erica, chairs • E61S  
Mirto Outdoor, table • MI250TG

Nella pagina accanto:  
Erica, divano • E170  
Erica, poltrona • E90P

Pushpam, tavolino • TF100RB  
Twist, tappeti • TW300

In questa pagina:  
Erica, sedie • EE61S  
Mirto Outdoor, tavolo • MI250TG







Opposite:  
Erica '19, sofa • 7NE170  
Allure'O Outdoor, table • OA225T\_6

Nella pagina accanto:  
Erica '19, divano • 7NE170  
Allure'O Outdoor, tavolo • OA225T\_6



Opposite:  
Allure O' Outdoor, table • OA225T\_6G  
Erica, chair • E61SB

---

Nella pagina accanto:  
Allure O' Outdoor, tavolo • OA225T\_6G  
Erica, sedia • E61SB

---

# Mirto Outdoor

Antonio Citterio



The quality and attention to details make Mirto a collection that is made to last.

L'aspetto qualitativo e la cura dei dettagli fanno di Mirto una collezione fatta per durare nel tempo.





Previous and these pages:  
Mirto Outdoor, sunbeds • MI200CL  
Mirto Outdoor, small tables • MI54T

In queste pagine e nelle precedenti:  
Mirto Outdoor, lettini • MI200CL  
Mirto Outdoor, tavolini • MI54T



These and next page:  
Mirto Outdoor, table • MI250TG  
Mirto Outdoor, chairs • MI5SS

Mirto Outdoor, small armchairs • MI65P  
Mirto Outdoor, console • MI250\_6G  
Twist, carpet • TW300

In queste pagine e nella successiva:  
Mirto Outdoor, tavolo • MI250TG  
Mirto Outdoor, sedie • MI5SS

Mirto Outdoor, poltroncine • MI65P  
Mirto Outdoor, console • MI250\_6G  
Twist, tappeto • TW300



This page:  
 Mirto Outdoor, low table • MI120\_4G  
 Twist, carpet • TW300

White Collection, vase • AB20046B  
 Bunch, vase  
 see catalogue B&B Italia "The Collection"

In questa pagina:  
 Mirto Outdoor, tavolo basso • MI120\_4G  
 Twist, tappeto • TW300

White Collection, vaso • AB20046B  
 Bunch, vaso  
 vedi catalogo B&B Italia "The Collection"







These pages:

Mirto Outdoor, table • TM0162Q  
Mirto Outdoor, folding small armchairs • MI59N  
Frank Outdoor, ottoman • OF58P  
Fat-Fat Outdoor, tray • OF42V  
Kyra, carpets • TY200

In queste pagine:

Mirto Outdoor, tavolo • TM0162Q  
Mirto Outdoor, poltroncine pieghevoli • MI59N  
Frank Outdoor, pouf • OF58P  
Fat-Fat Outdoor, vassoio • OF42V  
Kyra, tappeti • TY200



These pages:  
 Mirto Outdoor, table • TMO162Q  
 Mirto Outdoor, folding small armchairs • MI59N

Frank Outdoor, ottoman • OF58P  
 Fat-Fat Outdoor, tray • OF42V  
 Kyra, carpets • TY200

In queste pagine:  
 Mirto Outdoor, tavolo • TMO162Q  
 Mirto Outdoor, poltroncine pieghevoli • MI59N

Frank Outdoor, pouf • OF58P  
 Fat-Fat Outdoor, vassoio • OF42V  
 Kyra, tappeti • TY200





Opposite:  
 Mirto Outdoor, low table • TM0162\_4  
 Mirto Outdoor, small table • MI54T  
 Frank Outdoor, ottomans • OF58P

Ribes, modular sofa • RBR141LB\_2 • RBR190PA  
 Kyra, carpets • TY200  
 \*Karam, floor baskets \*B&B Italia archive

Nella pagina accanto:  
 Mirto Outdoor, tavolo basso • TM0162\_4  
 Mirto Outdoor, tavolino • MI54T  
 Frank Outdoor, pouf • OF58P

Ribes, divano componibile • RBR141LB\_2 • RBR190PA  
 Kyra, tappeti • TY200  
 \*Karam, ceste da terra \*Archivio B&B Italia

# Ray Outdoor Fabric-Natural

Antonio Citterio

Both featured by structures covered with interlaced materials: Ray Outdoor is created using a ribbon pattern composed by polypropylene fibres resistant to UV rays and weathering; while Ray Outdoor Natural features an interlacing rope pattern reminiscent of Manila hemp, in perfect harmony with nature.

Entrambi caratterizzati dalla struttura rivestita ad intreccio, Ray Outdoor Fabric si distingue per l'intreccio a nastro realizzato in fibra di polipropilene resistente ai raggi UV ed agli agenti atmosferici, Ray Outdoor Natural per l'intreccio a "corda" che si rifà all'abaca naturale, in perfetta armonia con la natura.





These pages:  
 Ray Outdoor Fabric, armchairs • RF85  
 Ray Outdoor Fabric, modular sofa • RF235D • RF235LS

Gio, low table • TGO12  
 Gio, small tables TGO6  
 Fat-Sofa Outdoor, ottoman • FA61P

Kaleidos, carpets • TKA300

In queste pagine:  
 Ray Outdoor Fabric, poltrone • RF85  
 Ray Outdoor Fabric, divano componibile • RF235D • RF235LS

Gio, tavolo basso • TGO12  
 Gio, tavolino • TGO6  
 Fat-Sofa Outdoor, pouf • FA61P

Kaleidos, tappeti • TKA300

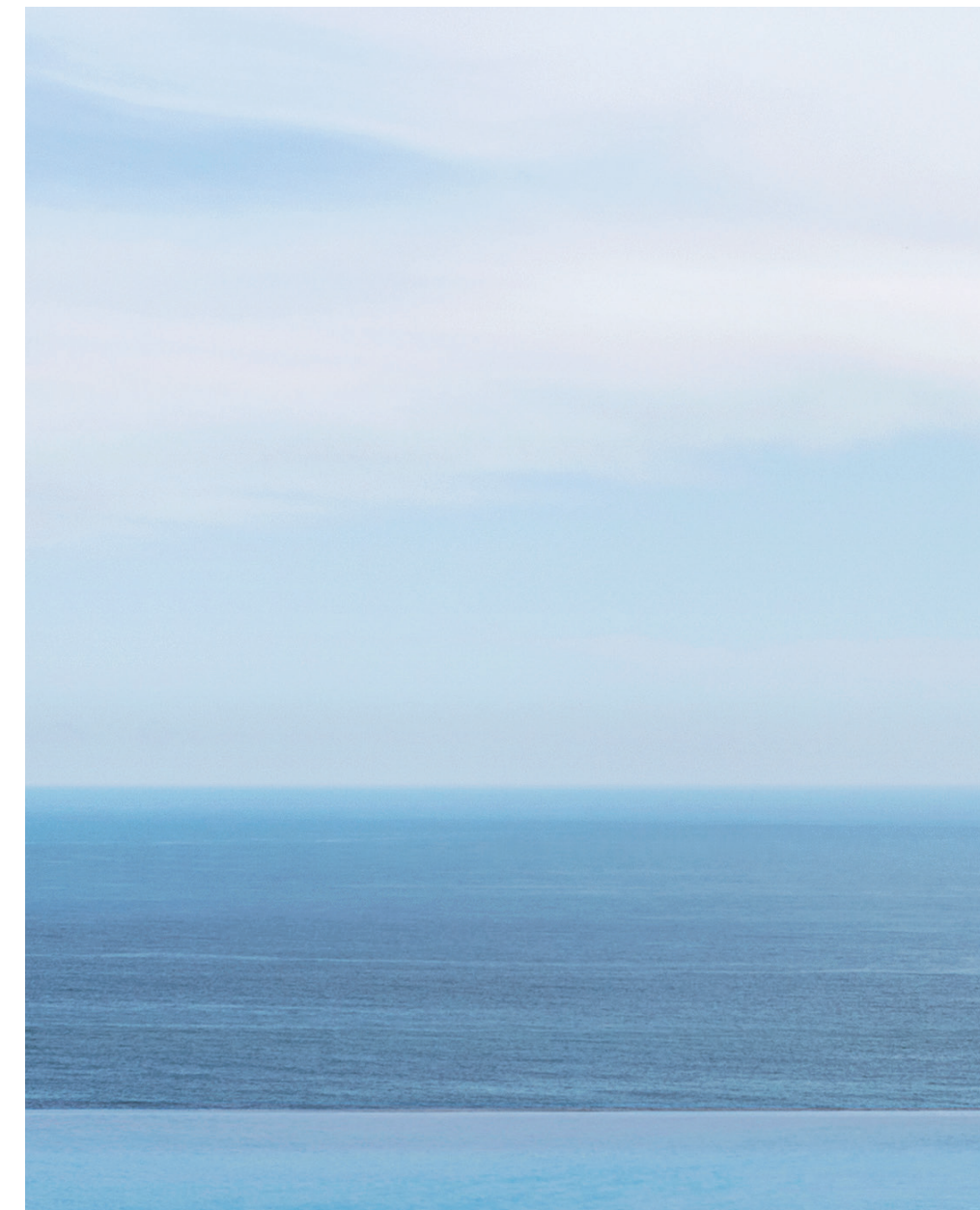

Opposite:  
Ray Outdoor Fabric, armchairs • RF85  
Gio, low table • TGO12

Kaleidos, carpet • TKA300

Nella pagina accanto:  
Ray Outdoor Fabric, poltrone • RF85  
Gio, tavolo basso • TGO12

Kaleidos, tappeto • TKA300



These pages:  
Ray Outdoor Fabric, sunbeds • RF203LA  
Gio, small table • TG06  
Husk Outdoor, tray • HT062V

In queste pagine:  
Ray Outdoor Fabric, lettini • RF203LA  
Gio, tavolino • TG06  
Husk Outdoor, vassoio • HT062V





These pages: Ray Outdoor Natural, sofa • RNL236\_B  
 Ray Outdoor Natural, chaise longue • RN236LD\_B  
 Ray Outdoor Natural, armchairs • RN86\_B

Gio, low table • TGO18  
 Gio, small table • TGO6  
 Twist, carpets • TW300

In queste pagine: Ray Outdoor Natural, divano • RNL236\_B  
 Ray Outdoor Natural, chaise longue • RN236LD\_B  
 Ray Outdoor Natural, poltrone • RN86\_B

Gio, tavolo basso • TGO18  
 Gio, tavolino • TGO6  
 Twist, tappeti • TW300

# Gio

Antonio Citterio

The solid teak structure with a special antique grey finish, gives the wood a particular lived-in aspect and silver-grey reflective quality.

La struttura in massello di teak nella speciale finitura antique grey, conferisce al legno un particolare aspetto vissuto con riflessi grigio argento.





These pages:  
Gio, modular sofa • G0233TD • G0197AD • G0197AS  
Gio, low table • TG012 Gio, small table • TG06

In queste pagine:  
Gio, divano componibile • G0233TD • G0197AD • G0197AS  
Gio, tavolo basso • TG012 Gio, tavolino • TG06



Opposite:  
Gio, sofa • G0238  
Gio, armchair • G064  
Gio, low table • TG018

Nella pagina accanto:  
Gio, divano • G0238  
Gio, poltrona • G064  
Gio, tavolo basso • TG018



These pages:  
Gio, sunbeds • G0200L  
Gio, small tables • TG06

In queste pagine:  
Gio, lettini • G0200L  
Gio, tavolini • TG06



Opposite:  
Gio, table • TG0280  
Gio, chairs • G058

Gio, bench • G0130P

Nella pagina accanto:  
Gio, tavolo • TG0280  
Gio, sedie • G058

Gio, panca • G0130P

# Charles Outdoor

Antonio Citterio

**Characteristics that made it a classic of pure contemporary taste have been left unchanged.**

Rimangono inalterate le caratteristiche che lo hanno reso un classico dal gusto decisamente contemporaneo.





These pages:  
 Charles Outdoor, modular sofa  
 CHO160LS • CHO234D

Charles Outdoor, armchair • CH084  
 Springtime, small table • TST7  
 Husk Outdoor, tray • HTO62V

\*Reel, service element  
 \*B&B Italia archive

In queste pagine:  
 Charles Outdoor, divano componibile  
 CHO160LS • CHO234D

Charles Outdoor, poltrona • CH084  
 Springtime, tavolino • TST7  
 Husk Outdoor, vassoio • HTO62V

\*Reel, elemento di servizio  
 \*Archivio B&B Italia





Opposite:  
Charles Outdoor, modular sofa  
CHO160LS • CHO234D

This page:  
Charles Outdoor, armchair • CH084  
Springtime, small table • TST7

Nella pagina accanto:  
Charles Outdoor, divano componibile  
CHO160LS • CHO234D

In questa pagina:  
Charles Outdoor, poltrona • CH084  
Springtime, tavolino • TST7

# Ginepro

Antonio Citterio

The table is made with an anthracite painted aluminum structure and a Serpentine stone top, extremely durable and precious as the linear and timeless style.

Il tavolo è realizzato con struttura in alluminio verniciato antracite e piano in pietra Serpentino, estremamente durevole e pregiata in linea con lo stile lineare e senza tempo.

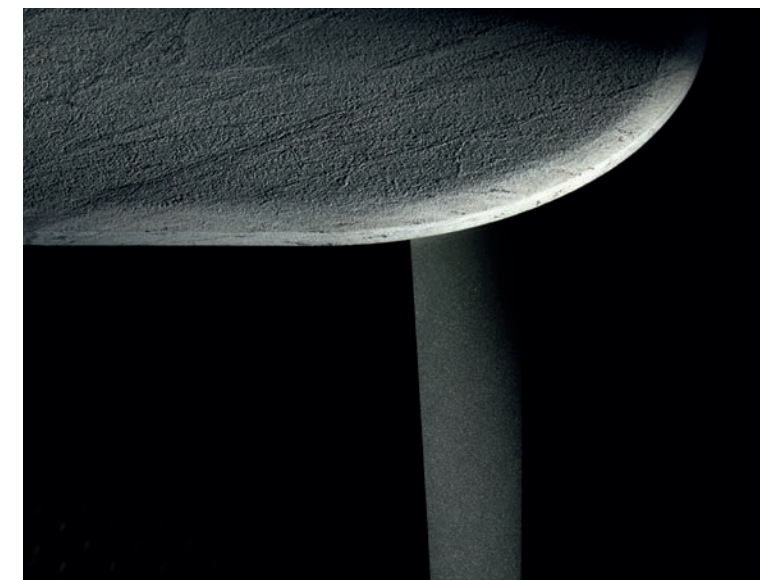
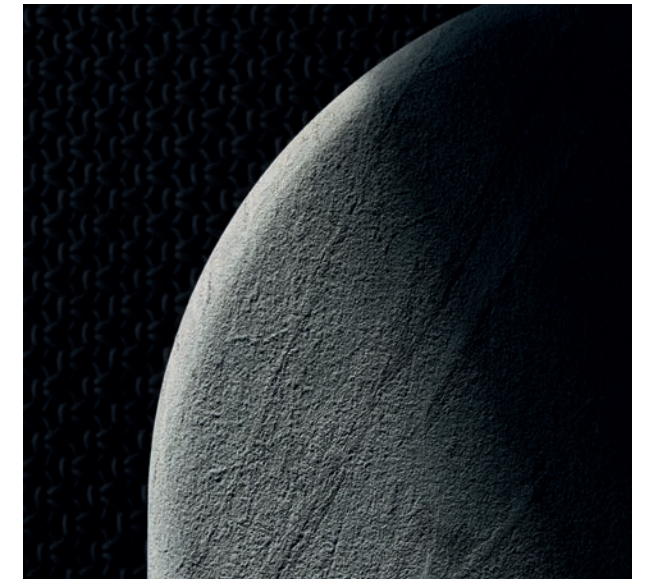



These pages:  
Ginepro, table • TGS250  
Erica, chairs • E61S

Hospes, ottomans • HE1 • HE2  
Kyra, carpet • TY200

In queste pagine:  
Ginepro, tavolo • TGS250  
Erica, sedie • E61S

Hospes, pouf • HE1 • HE2  
Kyra, tappeto • TY200



Opposite:  
Ginepro, table • TGS105R  
Erica, chairs • E61S

Hospes, ottoman • HE2

Nella pagina accanto:  
Ginepro, tavolo • TGS105R  
Erica, sedie • E61S

Hospes, pouf • HE2



# Bay

Nipa Doshi & Jonathan Levien



A collection of sculptural and monolithic yet visually light outdoor seats.

Una collezione di sedute da esterno dall'aspetto scultoreo e monolitico, al contempo visivamente leggero.



This pages:  
Bay, sofa • BY176CL  
Bay, small armchair • BY94N  
Bay, ottomans • BY74PQ  
Tobi-Ishi Outdoor, low table • OT146  
Kyra, carpets • TY200

In queste pagine:  
Bay, divano • BY176CL  
Bay, poltroncina • BY94N  
Bay, pouf • BY74PQ  
Tobi-Ishi Outdoor, tavolo basso • OT146  
Kyra, tappeti • TY200



This pages:  
 Bay, sofa • BY176CL  
 Bay, small armchair • BY94N

Bay, ottoman • BY74PQ  
 Tobi-Ishi Outdoor, low table • OT146  
 Kyra, carpets • TY200

In queste pagine:  
 Bay, divano • BY176CL  
 Bay, poltroncina • BY94N

Bay, pouf • BY74PQ  
 Tobi-Ishi Outdoor, tavolo basso • OT146  
 Kyra, tappeti • TY200



These pages:  
 Bay, sofa • BY236  
 Bay, armchair with high back • BY123A

\*Tabour Outdoor, ottoman  
 \*B&B Italia archive  
 Twist, carpets • TW300

In queste pagine:  
 Bay, divano • BY236  
 Bay, poltrona con schienale alto • BY123A

\*Tabour Outdoor, pouf  
 \*Archivio B&B Italia  
 Twist, tappeti • TW300



# Ginestra

Antonio Citterio

Sinuous harmonious lines clearly inspired by northern trends. It is characterised by an interlacing in polypropylene fibre that is ideal for outdoor use.

Dalle linee sinuose e fluide di chiara ispirazione nordica, caratterizzata da un intreccio di nastri in tessuto sintetico adatto all'utilizzo outdoor.





These pages:  
Ginestra, table • GN280T  
Ginestra, chairs • GN60

Twist, carpets • TW300

In queste pagine:  
Ginestra, tavolo • GN280T  
Ginestra, sedie • GN60

Twist, tappeti • TW300



Opposite:  
Ginestra, table • GN180TR  
Ginestra, chairs • GN60

Nella pagina accanto:  
Ginestra, tavolo • GN180TR  
Ginestra, sedie • GN60

# Butterfly

Patricia Urquiola

Its name comes from the “butterfly” shape created by the outer corner that joins the armrest and the backrest.

Prende il suo nome dalla forma a “farfalla” che disegna l’angolo esterno di unione tra bracciolo e schienale.





These and next pages:  
Butterfly, modular sofa  
BT112S • BT90C • BT112D

Butterfly, small tables • BT9R • BT7

In queste pagine e nelle successive:  
Butterfly, divano componibile  
BT112S • BT90C • BT112D

Butterfly, tavolini • BT9R • BT7





These pages:  
Butterfly, modular sofa  
BT112S • BT90C • BT90P • BT112D

Butterfly, ottomans • BT90P  
Butterfly, low table • BT15  
Overscale Flames Outdoor, oil candles • AB20044B

In queste pagine:  
Butterfly, divano componibile  
BT112S • BT90C • BT90P • BT112D

Butterfly, pouf • BT90P  
Butterfly, tavolo basso • BT15  
Overscale Flames Outdoor, candele ad olio • AB20044B

# Fat-Sofa Outdoor

Patricia Urquiola

The rounded, soft and sinuous shapes of the Fat-Sofa seating system are the base for the outdoor version, characterized by a brand new interlacing design.

Le forme arrotondate, morbide e sinuose del sistema di sedute Fat-Sofa vengono riprese nella versione da esterni, caratterizzata da un'inedita proposta di intreccio.







These pages:  
Fat-Sofa Outdoor, sofa • FA230  
Fat-Sofa Outdoor, armchairs with high back • FA91A

Butterfly, low table • BT15

In queste pagine:  
Fat-Sofa Outdoor, divano • FA230

Fat-Sofa Outdoor, poltrone con schienale alto • FA91A  
Butterfly, tavolo basso • BT15



Opposite:  
Fat-Sofa Outdoor, sofa • FA150  
Husk Outdoor, tray • HTO62V

Nella pagina accanto:  
Fat-Sofa Outdoor, divano • FA150  
Husk Outdoor, vassoio • HTO62V



# Canasta Canasta '13

Patricia Urquiola

For Canasta, the play between classic and contemporary is without any nostalgia: if the Viennese cane inspiration is retro, the polyethylene texture speaks today's language. The Canasta' 13 series maintain the iconic design and the typologies of the entire Canasta series, but with a new look designed to blend in with the external environment even more.

Per Canasta, il gioco tra il classico ed il contemporaneo è senza alcuna nostalgia: se l'ispirazione alla paglia di Vienna è retro, la texture in polietilene parla il linguaggio di oggi. La serie Canasta '13 mantiene il design iconico e le tipologie di tutta la serie Canasta e cambia "veste" per fondersi maggiormente con l'ambiente esterno.





These pages:  
Canasta, sofa with canopy and wheels  
CN160P1 • CN160P1C

Canasta '13, small tables • TCNC3 • TCNC4

In queste pagine:  
Canasta, divano con capote e ruote  
CN160P1 • CN160P1C

Canasta '13, tavolini • TCNC3 • TCNC4



These pages:  
Canasta, sofa • CN160P1  
Canasta, armchairs with high back • CN98PA

In queste pagine:  
Canasta, divano • CN160P1  
Canasta, poltrone con schienale alto • CN98PA





Opposite:  
 Canasta, table • TCN283N  
 Crinoline, chairs • C2P

White Collection, stool • AB20048B

Nella pagina accanto:  
 Canasta, tavolo • TCN283N  
 Crinoline, sedie • C2P

White Collection, sgabello • AB20048B

Opposite:  
Canasta, low table • TCN12  
Canasta '13, small table • TCNC4

Joker, vases  
see catalogue B&B italia "The Collection"

Nella pagina accanto:  
Canasta, tavolo basso • TCN12  
Canasta '13, tavolino • TCNC4

Joker, vasi  
vedi catalogo B&B Italia "The Collection"

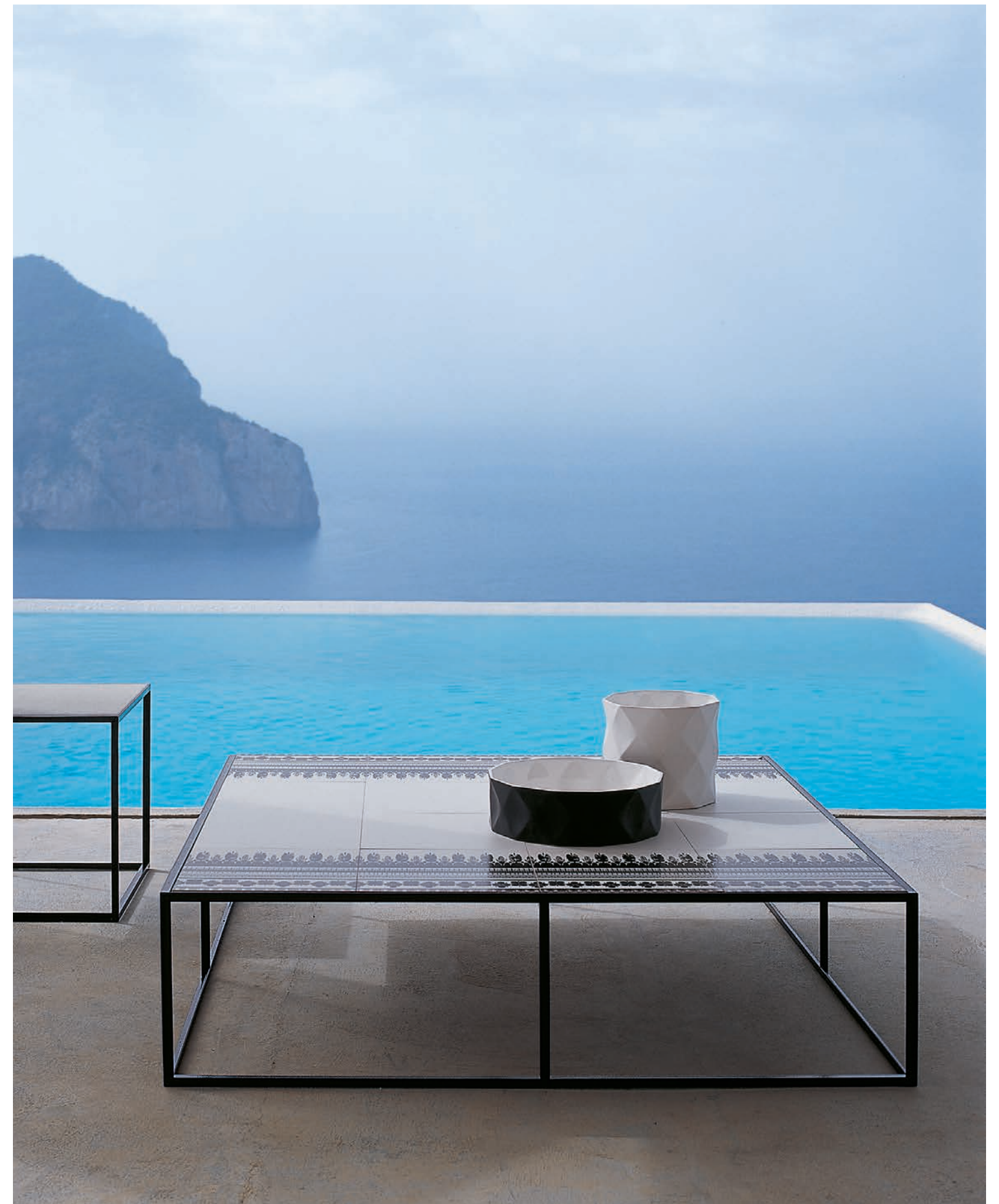



These pages:  
Canasta '13, sofa • CNC160P1  
Spool Outdoor, round small table • OS40T

In queste pagine:  
Canasta '13, divano • CNC160P1  
Spool Outdoor, tavolino rotondo • OS40T





This page:  
 Canasta '13, sofa • CNC160P1 • CNC160P1C

Opposite:  
 Canasta '13, sofa • CNC160P1

In questa pagina:  
 Canasta '13, divano • CNC160P1 • CNC160P1C

Nella pagina accanto:  
 Canasta '13, divano • CNC160P1



Opposite:  
Canasta '13, armchairs • CNC98PA  
Canasta '13, ottoman • PCNC60

Nella pagina accanto:  
Canasta '13, poltrona • CNC98PA  
Canasta '13, pouf • PCNC60

# Crinoline

Patricia Urquiola

Can you picture the dresses that women wore in the 1800s? Full, bell-shaped skirts held by crinolines (rigid underskirt garments) were spectacular “micro-architectures”.

Avete presente le gonne delle dame ottocentesche? Gonfie, a campana, sostenute dalle crinoline (sottogonne rigide). Erano scenografiche micro-architetture.



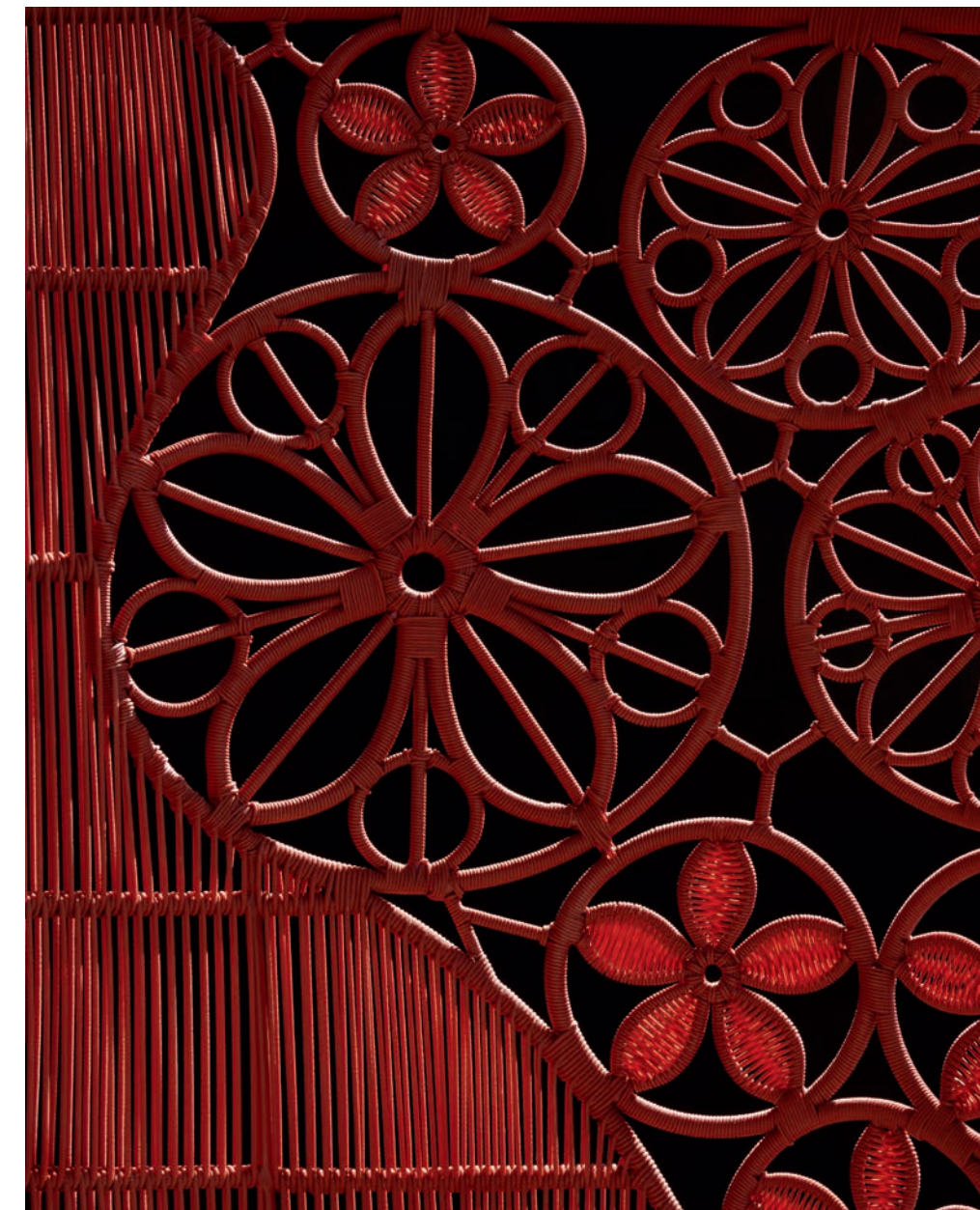

These pages:  
[Crinoline, armchair • C5P\\_FL](#)

In queste pagine:  
[Crinoline, poltrona • C5P\\_FL](#)



These pages:  
[Crinoline, armchairs C5C • C5P](#)

In queste pagine:  
[Crinoline, poltrone C5C • C5P](#)



Opposite:  
Crinoline, chairs with armrests • C2PF  
Tobi-Ishi Outdoor, table • OT162

Nella pagina accanto:  
Crinoline, sedie con braccioli • C2PF  
Tobi-Ishi Outdoor, tavolo • OT162



# Tobi-Ishi Outdoor

Edward Barber & Jay Osgerby

The name and inspiration come from the smooth stones “tobi-ishi” used as ornaments in traditional Zen gardens.

Il nome e l'ispirazione sono un riferimento alle pietre levigate “tobi-ishi” usate con funzione ornamentale nei tradizionali giardini zen.

Opposite:  
Tobi-Ishi Outdoor, table • OT162

---

Nella pagina accanto:  
Tobi-Ishi Outdoor, tavolo • OT162

---



# Link Outdoor

Jakob Wagner

It stands out for its “soft” material and sensual shape. The material makes you want to reach out and touch its smooth surface.

Si distingue per la sua matericità “morbida”, per la sensualità della sua forma e del suo materiale che suscitano il desiderio di sfiorarne la superficie levigata.





These pages and previous page:  
Link Outdoor, table • TLK250N  
White Collection, vase • AB20046B  
\*Mini Papilio Outdoor, chairs  
\*B&B Italia archive

In queste pagine e nella precedente:  
Link Outdoor, tavolo • TLK250N  
White Collection, vaso • AB20046B  
\*Mini Papilio Outdoor, sedie  
\*Archivio B&B Italia



# Cosmos Outdoor

Jeffrey Bennett

A series of compact, streamlined tables which can be used individually or clustered together. Suitable both for public and residential spaces.

Serie di tavoli dalle linee armoniose che possono essere utilizzati in coppia o in piccoli gruppi. Ideali sia in spazi pubblici che residenziali.

Opposite:  
Cosmos Outdoor, table • OTC90R\_1

Nella pagina accanto:  
Cosmos Outdoor, tavolo • OTC90R\_1



# Pushpam

Naoto Fukasawa

“I have called my latest project Pushpam, or flower in Indonesian, because the Papilio Shell chairs sit around these tables like butterflies flying around a flower”.  
Naoto Fukasawa

“Ho chiamato questo nuovo tavolo Pushpam (fiore in indonesiano) perché è un tavolo a cui le Papilio Shell stanno intorno come le farfalle volano intorno al fiore”.  
Naoto Fukasawa

Opposite:  
Pushpam, table • TF100RA  
Papilio Shell Outdoor, chairs • OSH1  
Fat-Sofa Outdoor, ottoman • FA61P

Nella pagina accanto:  
Pushpam, tavolo • TF100RA  
Papilio Shell Outdoor, sedie • OSH1  
Fat-Sofa Outdoor, pouf • FA61P



# Papilio Shell Outdoor

Naoto Fukasawa

A chair characterised by a shell whose design evokes the Papilio butterfly. Comfort is ensured thanks to its cocooning wings.

Una sedia originata da una scocca, il cui schienale evoca formalmente le ali di una farfalla che accoglie comodamente ed abbraccia l'ospite.

Opposite:  
Papilio Shell Outdoor, chairs • OSH1  
Pushpam, table • TF100RA

Nella pagina accanto:  
Papilio Shell Outdoor, sedia • OSH1  
Pushpam, tavolo • TF100RA



# Husk Outdoor

Patricia Urquiola

A collection of armchairs and chairs with an original personality characterized by soft and cosy cushions divided into small sections evoking relaxation at first sight.

Una serie di poltrone e sedie dalla personalità originale caratterizzata da una soffice e avvolgente cuscineria suddivisa in porzioni che invita al relax già al primo sguardo.

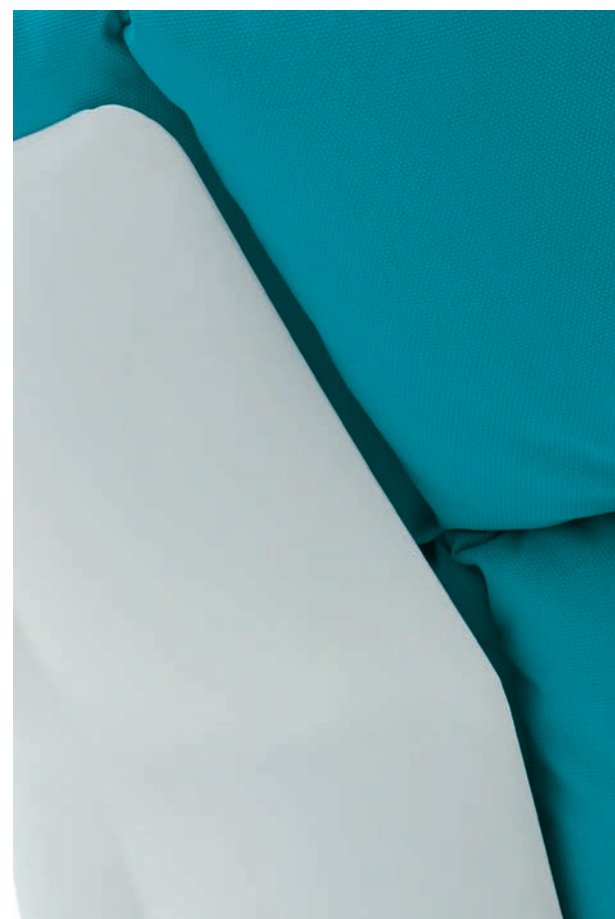

Previous page:  
 Husk Outdoor, armchairs • H4 • H2  
 Husk Outdoor, small table • HT

Opposite:  
 Husk Outdoor, small table • HT062  
 Butterfly, modular sofa  
 Twist, carpet • TW300

Nella pagina precedente:  
 Husk Outdoor, poltrone • H4 • H2  
 Husk Outdoor, tavolino • HT

Nella pagina accanto:  
 Husk Outdoor, tavolino • HT062  
 Butterfly, divano componibile  
 Twist, tappeto • TW300



# Spool Outdoor

Piero Lissoni

An extremely versatile outdoor accessory able to add character to the setting thanks to its lively distinctive form.

Un complemento estremamente versatile in grado di conferire carattere agli ambienti grazie alla vivace proposta cromatica.

Opposite:  
Spool Outdoor, small table • OS40T  
Borea, sofa • BE243

Nella pagina accanto:  
Spool Outdoor, tavolino • OS40T  
Borea, divano • BE243

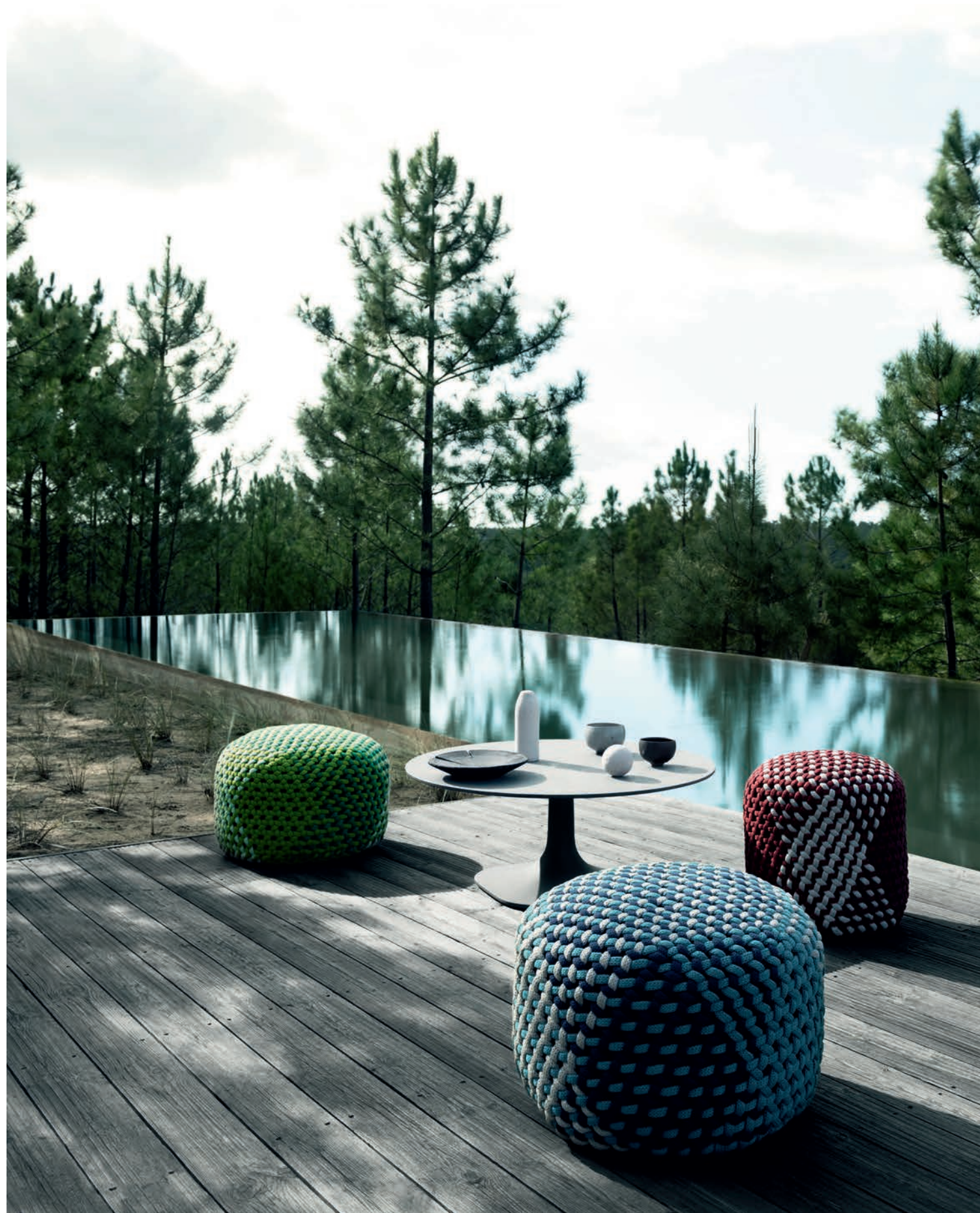

# Tramae

unPIZZO

A three dimensional ottoman with a strong personality, thanks to its colourful weave that reinterprets tradition basket weaving giving it a new contemporary twist.

Un pouf in tre dimensioni con una forte personalità colorata che reinterpreta il tradizionale intreccio dei cesti in vimini in chiave contemporanea.



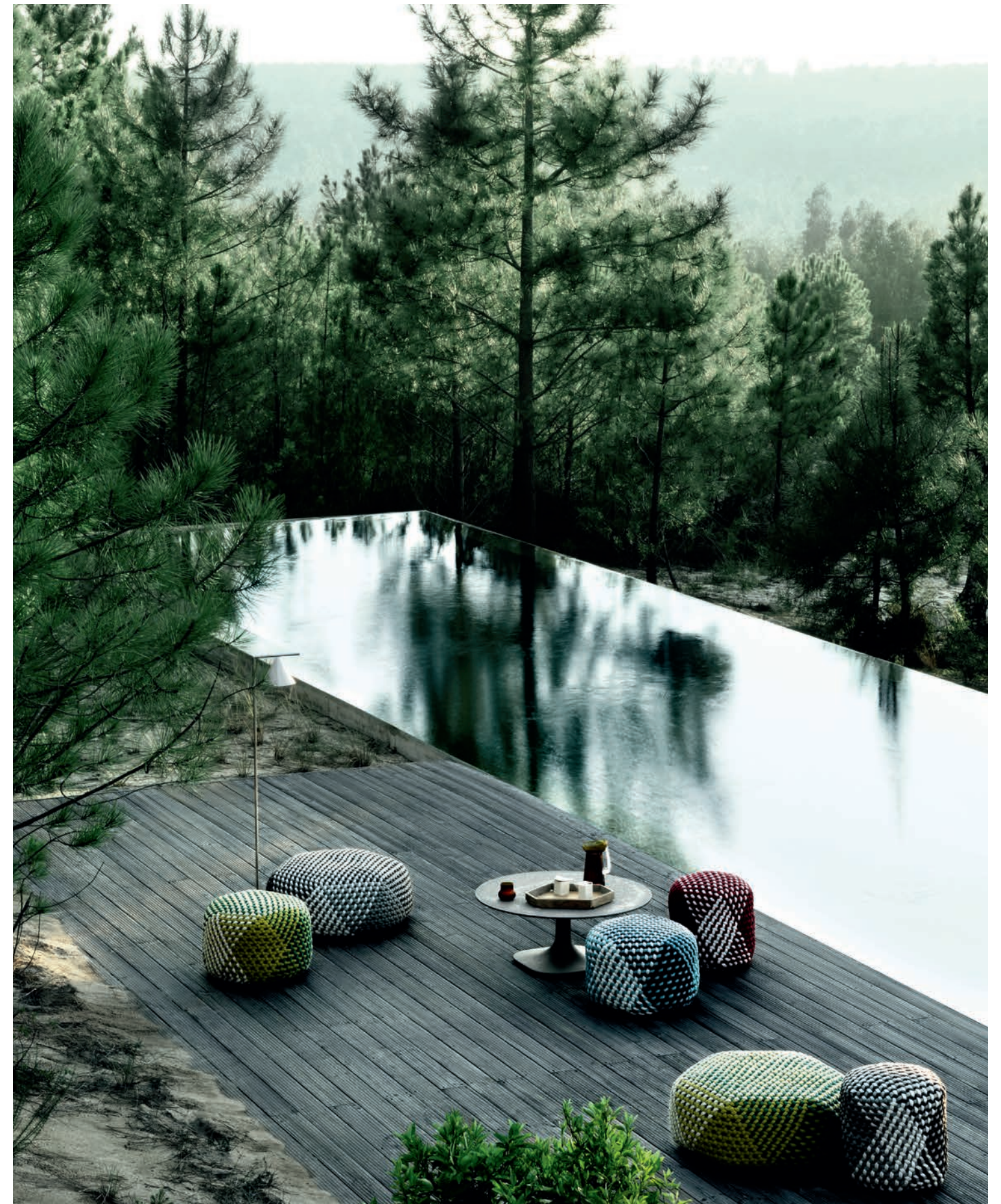
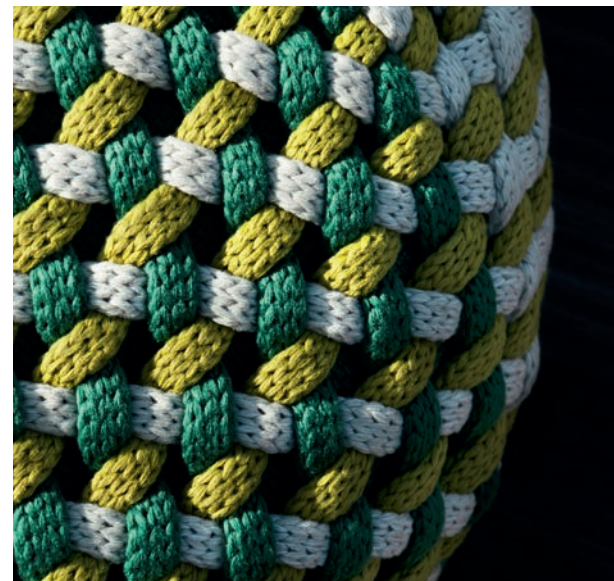
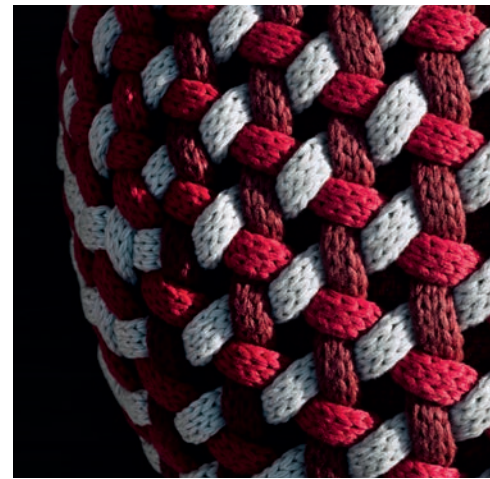
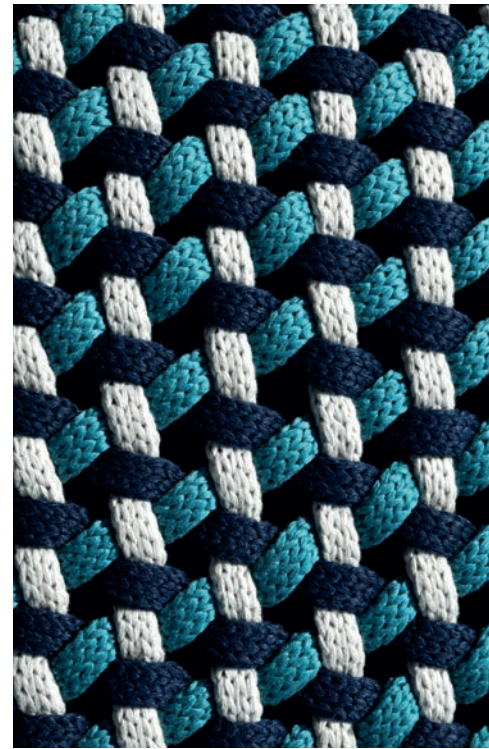

Previous and opposite page:  
Tramae, ottomans • TRM47P • TRM60P • TRM90P  
Pushpam, small table • TF100RB

Nella pagina accanto e nella precedente:  
Tramae, pouf • TRM47P • TRM60P • TRM90P  
Pushpam, tavolino • TF100RB



# Hospes

B&B Italia CR&S

A versatile ottoman in two sizes that can be used in many ways and fits perfectly with different product families.

Un pouf versatile e dinamico in due dimensioni che si adatta a varie situazioni e a diverse famiglie di prodotto.

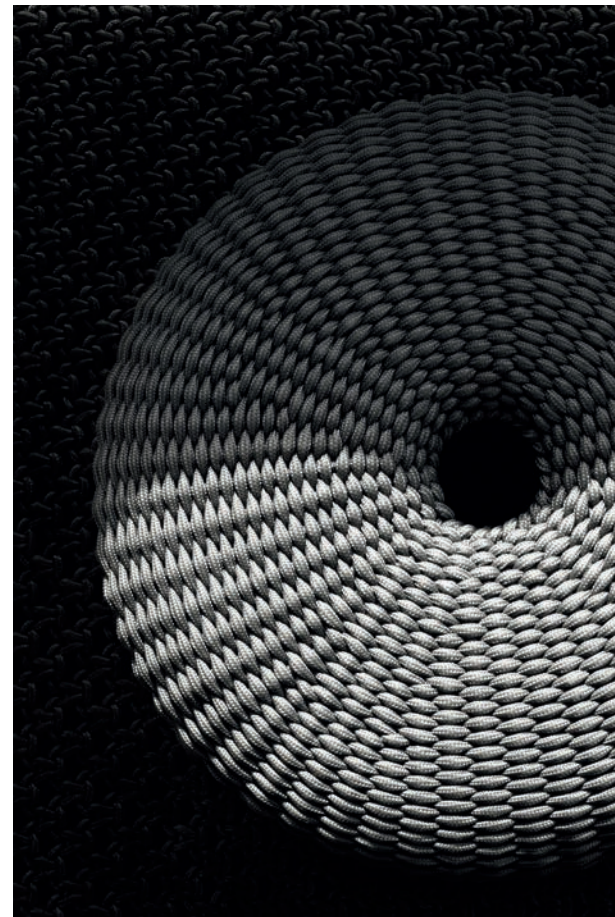
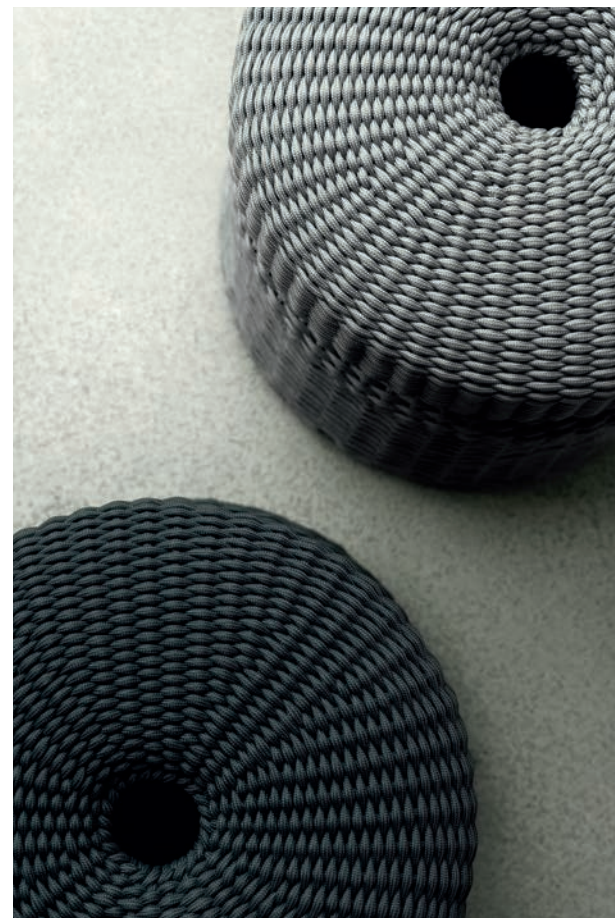

Previous and opposite page:  
Hospes, ottomans • HE1 • HE2

Nella pagina accanto e nella precedente:  
Hospes, pouf • HE1 • HE2



# Colosseo Outdoor

Naoto Fukasawa

Colosseo debuts outdoor in a porcelain stoneware version. A furniture element with various functions depending on the setting.

Colosseo debutta outdoor nella nuova versione in gres porcellanato. Elemento di arredo con varie funzioni a seconda delle occasioni e delle necessità.

Opposite:  
Colosseo, service elements • OCL40T • OCL45T

Nella pagina accanto:  
Colosseo, elementi di servizio • OCL40T • OCL45T



# Fat-Fat Outdoor

Patricia Urquiola

The concept of a tray helped create three small outdoor tables with steel frames that give them a lightweight look. These small tables are entirely painted or with tops in porcelain stoneware.

Il tema del vassoio viene ripreso per dar vita a tre tavolini per esterni il cui aspetto leggero è merito della struttura in acciaio. I tavolini sono proposti interamente verniciati oppure con piano in gres porcellanato.

Opposite:  
Fat-Fat Outdoor, small tables • OTF62  
Erica, sofa • E216  
Erica, armchair • E80P

Nella pagina accanto:  
Fat-Fat Outdoor, tavolini • OTF62  
Erica, divano • E216  
Erica, poltrona • E80P



# Awa Outdoor

Naoto Fukasawa

Base and top are integrated: aesthetically, it's the epitome of essential elegance.

Base e piano sono un unicuum: l'estetica si divide tra l'eleganza e l'essenzialità.

Opposite:  
Awa Outdoor, small table • TA1  
Butterfly, modular sofa • BT112D • BT112S

---

Nella pagina accanto:  
Awa Outdoor, tavolino • TA1  
Butterfly, divano componibile • BT112D • BT112S

---



# Titikaka

Naoto Fukasawa

It revolutionises the concept of a bench. The traditional typology of the outdoor bench is revamped with contemporary language. It's an impressive piece that resembles a sculpture.

Rivoluziona il concetto di panchina. Ripropone la tradizionale tipologia della panca per esterni con linguaggio contemporaneo e si impone per la sua presenza scultorea.

Opposite:  
Titikaka, bench • TK

---

Nella pagina accanto:  
Titikaka, panca • TK

---



# Overscale Flames Outdoor

Jean-Marie Massaud

The large oil candles designed by Jean-Marie Massaud are enclosed by a metallic frame painted matt white.

Le grandi candele a olio disegnate da Jean-Marie Massaud sono sostenute da una struttura metallica verniciata bianca opaca.

Opposite:  
Overscale, oil candles • AB20044B

Nella pagina accanto:  
Overscale, candele ad olio • AB20044B





# White Collection

Marcel Wanders

The Gold Collection by Marcel Wanders is available in the white version: vases and stool are in ceramic, also suitable for outdoor use.

La Gold Collection firmata da Marcel Wanders viene proposta in versione bianca: vasi e sgabello sono in ceramica, adatta anche per esterno.

Opposite:  
White Collection, vases • AB20046B

---

Nella pagina accanto:  
White Collection, vasi • AB20046B

---



# Springtime

Jean-Marie Massaud

The Springtime complements are designed by Jean-Marie Massaud as furnishing elements of an outdoor area that conceptually dialogues between nature and interior spaces.

I complementi Springtime sono pensati da Jean-Marie Massaud come elementi di arredo di un'area esterna che dialoga concettualmente tra natura e spazi interni della casa.

Opposite:  
Springtime, small tables • TST4 • TST7

Nella pagina accanto:  
Springtime, tavolini • TST4 • TST7



# Frank Outdoor

Antonio Citterio

This outdoor ottomans have contrasting profiles matched to colourful outdoor fabrics to provide a touch of colour to the outdoor furnishings.

Pouf per esterni che si caratterizzano per l'abbinamento di profili a contrasto abbinati a colorati tessuti outdoor che donano una nota di colore agli arredi per esterno.

Opposite:  
Frank Outdoor, ottomans • OF58P

Nella pagina accanto:  
Frank Outdoor, pouf • OF58P



# Kyra

B&B Italia CR&S

Designed to guarantee high performance outdoor, Kyra carpets are made entirely by hand in a single size and they come in different colours.

Progettati per garantire alte prestazioni in ambienti esterni, i tappeti Kyra sono realizzati interamente a mano in una unica dimensione e sono proposti in diverse tonalità di colori.



# Piet

B&B Italia CR&S

An homage to the painter Piet Mondrian who inspired the geometric lined pattern that decorates the carpet.

Un omaggio al pittore Piet Mondrian che ha ispirato il disegno geometrico delle linee che decorano il tappeto.



# Twist Kaleidos

Specifically designed for outdoor use, marked by permeability and breathability.

Studiati appositamente per l'utilizzo all'aperto con caratteristiche di permeabilità e traspirabilità.

Sofas  
Divani



**Ayana**  
Naoto Fukasawa

Specifications 22

Inspiration 105



**Bay**  
Nipa Doshi and Jonathan Levien

Specifications 32

Inspiration 231



**Erica '19**  
Antonio Citterio

Specifications 104

Inspiration 161



**Erica '19**  
Antonio Citterio

Specifications 104

Inspiration 161



**Bay**  
Nipa Doshi and Jonathan Levien

Specifications 32

Inspiration 231



**Borea**  
Piero Lissoni

Specifications 40

Inspiration 81



**Fat-Sofa Outdoor**  
Patricia Urquiola

Specifications 118

Inspiration 253



**Fat-Sofa Outdoor**  
Patricia Urquiola

Specifications 118

Inspiration 253



**Canasta**  
Patricia Urquiola

Specifications 62

Inspiration 259



**Canasta**  
Patricia Urquiola

Specifications 62

Inspiration 259



**Gio**  
Antonio Citterio

Specifications 136

Inspiration 209



**Hybrid**  
Antonio Citterio

Specifications 154

Inspiration 117



**Canasta '13**  
Patricia Urquiola

Specifications 72

Inspiration 268



**Canasta '13**  
Patricia Urquiola

Specifications 72

Inspiration 268



**Oh, it rains!**  
Philippe Starck

Specifications 202

Inspiration 129



**Pablo Outdoor**  
Vincent Van Duysen

Specifications 208

Inspiration 63



**Canasta**  
Patricia Urquiola

Specifications 62

Inspiration 259



**Canasta '13**  
Patricia Urquiola

Specifications 72

Inspiration 268



**Ray Outdoor Fabric**  
Antonio Citterio  
228 • Inspiration 200

Specifications 62

Inspiration 259



**Ray Outdoor Natural**  
Antonio Citterio  
234 • Inspiration 206

Specifications 72

Inspiration 268



**Charles Outdoor**  
Antonio Citterio

Specifications 78

Inspiration 219



**Erica**  
Antonio Citterio

Specifications 98

Inspiration 161



**Ribes**  
Antonio Citterio

Specifications 242

Inspiration 141



**Ribes**  
Antonio Citterio

Specifications 242

Inspiration 141

### Modular sofas Divani componibili



**Butterfly**  
Patricia Urquiola

Specifications 58

Inspiration 245



**Gio**  
Antonio Citterio

Specifications 136

Inspiration 209



**Nooch**  
Piero Lissoni

Specifications 190

Inspiration 5



**Ray Outdoor Natural**  
Antonio Citterio

Specifications 234

Inspiration 206



**Ribes**  
Antonio Citterio

Specifications 242

Inspiration 141



**Charles Outdoor**  
Antonio Citterio

Specifications 78

Inspiration 219



**Hybrid**  
Antonio Citterio

Specifications 154

Inspiration 117



**Ray Outdoor Fabric**  
Antonio Citterio

Specifications 228

Inspiration 200



**Ray Outdoor Natural**  
Antonio Citterio

Specifications 234

Inspiration 206



**Ribes**  
Antonio Citterio

Specifications 242

Inspiration 141

### Chaise Longue Chaise Longue



**Hybrid**  
Antonio Citterio

Specifications 154

Inspiration 117



**Ray Outdoor Fabric**  
Antonio Citterio

Specifications 228

Inspiration 200



**Ray Outdoor Natural**  
Antonio Citterio

Specifications 234

Inspiration 206

### Sunbeds Lettini



**Borea**  
Piero Lissoni

Specifications 40

Inspiration 81



**Mirto Outdoor**  
Antonio Citterio

Specifications 170

Inspiration 181



**Ray Outdoor Fabric**  
Antonio Citterio

Specifications 228

Inspiration 200



**Nooch**  
Piero Lissoni

Specifications 190

Inspiration 5



**Ray Outdoor Natural**  
Antonio Citterio

Specifications 234

Inspiration 206



**Ribes**  
Antonio Citterio

Specifications 242

Inspiration 141



**Gio**  
Antonio Citterio

Specifications 136

Inspiration 209



**Mirto Outdoor**  
Antonio Citterio

Specifications 170

Inspiration 181



### Armchairs and small armchairs Poltrone e poltroncine



**Ayana**  
Naoto Fukasawa

Specifications 22

Inspiration 105



**Bay**  
Nipa Doshi and Jonathan Levien

Specifications 32

Inspiration 231



**Fat-Sofa Outdoor**  
Patricia Urquiola

Specifications 118

Inspiration 253



**Gio**  
Antonio Citterio

Specifications 136

Inspiration 209



**Bay**  
Nipa Doshi and Jonathan Levien

Specifications 32

Inspiration 231



**Borea**  
Piero Lissoni

Specifications 40

Inspiration 81



**Husk Outdoor**  
Patricia Urquiola

Specifications 148

Inspiration 294



**Mirto Outdoor**  
Antonio Citterio

Specifications 170

Inspiration 181



**Borea**  
Piero Lissoni

Specifications 40

Inspiration 81



**Canasta**  
Patricia Urquiola

Specifications 62

Inspiration 259



**Nooch**  
Piero Lissoni

Specifications 190

Inspiration 5



**Oh, it rains!**  
Philippe Starck

Specifications 202

Inspiration 129



**Canasta '13**  
Patricia Urquiola

Specifications 72

Inspiration 268



**Charles Outdoor**  
Antonio Citterio

Specifications 78

Inspiration 219



**Pablo Outdoor**  
Vincent Van Duysen

Specifications 208

Inspiration 63



**Ray Outdoor Fabric**  
Antonio Citterio

Specifications 228

Inspiration 200



**Cordoba Outdoor**  
Foster+Partners,  
Industrial Design Studio

Specifications 86

Inspiration 37

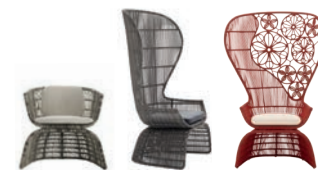

**Crinoline**  
Patricia Urquiola

Specifications 92

Inspiration 275



**Ray Outdoor Natural**  
Antonio Citterio

Specifications 234

Inspiration 206



**Ray Outdoor Natural**  
Antonio Citterio

Specifications 234

Inspiration 206



**Erica**  
Antonio Citterio

Specifications 98

Inspiration 161



**Erica '19**  
Antonio Citterio

Specifications 104

Inspiration 161

### Ottomans Pouf



**Bay**  
Nipa Doshi and Jonathan Levien

Specifications 32

Inspiration 231



**Frank Outdoor**  
Antonio Citterio

Specifications 126

Inspiration 322



**Hospes**  
B&B Italia CR&S

Specifications 146

Inspiration 304



**Nooch**  
Piero Lissoni

Specifications 190

Inspiration 5



**Ribes**  
Antonio Citterio

Specifications 242

Inspiration 141



**Fat-Sofa Outdoor**  
Patricia Urquiola

Specifications 118

Inspiration 253



**Hybrid**  
Antonio Citterio

Specifications 154

Inspiration 117



**Husk Outdoor**  
Patricia Urquiola

Specifications 148

Inspiration 294



**Pablo Outdoor**  
Vincent Van Duysen

Specifications 208

Inspiration 63



**Tramae**  
unPIZZO

Specifications 268

Inspiration 300

### Tables Tavoli



**Allure O' Outdoor**  
Monica Armani

Specifications 16

Inspiration 45

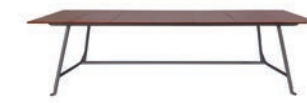

**Borea**  
Piero Lissoni

Specifications 40

Inspiration 81



**Cosmos Outdoor**  
Jeffrey Bennett

Specifications 90

Inspiration 288



**Ginepro**  
Antonio Citterio

Specifications 128

Inspiration 225



**Ginestra**  
Antonio Citterio

Specifications 132

Inspiration 239



**Link Outdoor**  
Jakob Wagner

Specifications 168

Inspiration 284



**Ayana**  
Naoto Fukasawa

Specifications 22

Inspiration 105



**Canasta**  
Patricia Urquiola

Specifications 68

Inspiration 264



**Ginepro**  
Antonio Citterio

Specifications 128

Inspiration 225



**Ginestra**  
Antonio Citterio

Specifications 132

Inspiration 239



**Gio**  
Antonio Citterio

Specifications 136

Inspiration 209



**Mirto Outdoor**  
Antonio Citterio

Specifications 170

Inspiration 181

Tables  
Tavoli



**Mirto Outdoor**  
Antonio Citterio

[Specifications 170](#)

[Inspiration 181](#)



**Pushpam**  
Naoto Fukasawa

[Specifications 226](#)

[Inspiration 290](#)



**Tobi-Ishi Outdoor**  
Edward Barber and Jay Osgerby

[Specifications 266](#)

[Inspiration 282](#)

Chairs  
Sedie



**Ayana**  
Naoto Fukasawa

[Specifications 22](#)

[Inspiration 105](#)



**Borea**  
Piero Lissoni

[Specifications 40](#)

[Inspiration 81](#)



**Canasta '13**  
Patricia Urquiola

[Specifications 72](#)

[Inspiration 268](#)



**Crinoline**  
Patricia Urquiola

[Specifications 92](#)

[Inspiration 275](#)



**Erica**  
Antonio Citterio

[Specifications 98](#)

[Inspiration 161](#)



**Erica '19**  
Antonio Citterio

[Specifications 104](#)

[Inspiration 161](#)



**Flair O'**  
Monica Armani

[Specifications 122](#)

[Inspiration 55](#)



**Ginestra**  
Antonio Citterio

[Specifications 132](#)

[Inspiration 239](#)



**Gio**  
Antonio Citterio

[Specifications 136](#)

[Inspiration 209](#)



**Husk Outdoor**  
Patricia Urquiola

[Specifications 148](#)

[Inspiration 294](#)



**Mirto Outdoor**  
Antonio Citterio

[Specifications 170](#)

[Inspiration 181](#)



**Papilio Shell Outdoor**  
Naoto Fukasawa

[Specifications 222](#)

[Inspiration 292](#)

## Low tables, small tables and service elements Tavoli bassi, tavolini ed elementi di servizio



**Awa Outdoor**  
Naoto Fukasawa

Specifications 20

Inspiration 312



**Borea**  
Piero Lissoni

Specifications 40

Inspiration 81

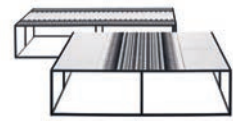

**Canasta**  
Patricia Urquiola

Specifications 62

Inspiration 259



**Canasta '13**  
Patricia Urquiola

Specifications 72

Inspiration 268



**Fat-Fat Outdoor**  
Patricia Urquiola

Specifications 116

Inspiration 310



**Husk Outdoor**  
Patricia Urquiola

Specifications 148

Inspiration 294



**Ayana**  
Naoto Fukasawa

Specifications 118

Inspiration 253



**Butterfly**  
Patricia Urquiola

Specifications 58

Inspiration 245



**Canasta**  
Patricia Urquiola

Specifications 62

Inspiration 259



**Canasta '13**  
Patricia Urquiola

Specifications 72

Inspiration 268



**Gio**  
Antonio Citterio

Specifications 136

Inspiration 209



**Mirto Outdoor**  
Antonio Citterio

Specifications 170

Inspiration 181

## Low tables and small tables Tavoli bassi e tavolini



**Mirto Outdoor**  
Antonio Citterio

Specifications 170

Inspiration 181



**Pablo Outdoor**  
Vincent Van Duysen

Specifications 208

Inspiration 63



**Pushpam**  
Naoto Fukasawa

Specifications 226

Inspiration 290



**Spool Outdoor**  
Piero Lissoni

Specifications 260

Inspiration 298



**Nooch**  
Piero Lissoni

Specifications 190

Inspiration 5



**Pablo Outdoor**  
Vincent Van Duysen

Specifications 208

Inspiration 63



**Tobi-Ishi Outdoor**  
Edward Barber and Jay Osgerby

Specifications 266

Inspiration 282

### Benches Panche



**Gio**  
Antonio Citterio

[Specifications 136](#)

[Inspiration 209](#)



**Ribes**  
Antonio Citterio

[Specifications 242](#)

[Inspiration 141](#)



**Hybrid**  
Antonio Citterio

[Specifications 154](#)

[Inspiration 117](#)



**Titikaka**  
Naoto Fukasawa

[Specifications 264](#)

[Inspiration 314](#)

### Carpets Tappeti



**Kaleidos**  
B&B Italia CR&S

[Specifications 164](#)

[Inspiration 328](#)



**Kyra**  
B&B Italia CR&S

[Specifications 166](#)

[Inspiration 234](#)

### Complements Complementi



**Colosseo Outdoor**  
Naoto Fukasawa

[Specifications 84](#)

[Inspiration 308](#)



**Overscale Flames Outdoor**  
Jean-Marie Massaud

[Specifications 206](#)

[Inspiration 316](#)

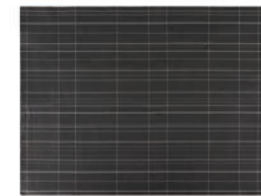

**Piet**  
B&B Italia CR&S

[Specifications 224](#)

[Inspiration 326](#)



**Twist**  
B&B Italia CR&S

[Specifications 270](#)

[Inspiration 328](#)



**Springtime**  
Jean-Marie Massaud

[Specifications 262](#)

[Inspiration 320](#)



**White Collection**  
Marcel Wanders

[Specifications 272](#)

[Inspiration 318](#)

## Allure O' Outdoor

Monica Armani • 2023

Inspiration • 45



The Allure O' table, a heartfelt tribute to glamour interpreted in contemporary style, is presented in an outdoor version that keeps the graceful force of its design, clearly visible in the shape of the top and the balance between straight lines and sinuous curves. It is proposed with square and rectangular tops and in two heights. In addition to the usual top height of 72 cm top, you can choose a 66 cm version, to accompany the Flair O' chairs but also the sofas and chairs in the other families of the B&B Italia Outdoor collection.

Il tavolo Allure O', sentito omaggio al glamour interpretato in chiave contemporanea, si presenta in una versione outdoor che mantiene intatta la forza aggraziata del suo design, chiaramente visibile nella forma del piano e nell'equilibrio tra linee rette e curve sinuose. E' proposto con piani quadrati e rettangolari e in due altezze. Oltre alla consueta altezza del piano di 72 cm, si potrà scegliere una versione da 66 cm, da accompagnare alle sedie Flair O' ma anche a divanetti e sedie di altre famiglie della collezione B&B Italia Outdoor.

## Allure O' Outdoor

### Monica Armani • 2023

Inspiration • 45



The tops are created in lightened grey concrete, and a surprising glossy glazed stoneware, a nostalgic material, used in the past for kitchen cooking surfaces. It is a material that is decidedly resistant to corrosive agents and the stains that can be caused by food, drinks and the typical situations of outdoor life. Produced with an artisanal technique, after a slow, single firing process at a temperature of 250 °C, the material is manually glazed by airbrush, a technique that allows for a unique depth and variety of colour.

The base-frame is made of moulded grey cement, a choice that gives Allure O' Outdoor extreme solidity and an appearance that easily adapts to any outdoor furnishing situation.

I piani sono previsti in cemento grigio alleggerito, e un sorprendente gres smaltato, materiale della memoria, utilizzato in passato per le superfici di cottura nelle cucine. Si tratta di un materiale decisamente resistente agli agenti corrosivi e alle macchie che possono derivare dal cibo, dalle bevande e dalle situazioni tipiche della vita all'aria aperta. Prodotto con tecnica artigianale, dopo un lento processo di monocottura alla temperatura di 250 °C, viene smaltato manualmente ad aerografo, tecnica che permette di ottenere una singolare profondità e varietà del colore.

Il basamento è realizzato in cemento grigio colato a stampo, una scelta che conferisce ad Allure O' Outdoor estrema solidità e un aspetto che si adatta facilmente a qualsiasi situazione di arredo outdoor.

Top	stonewear or cement (ultra high performance concrete)
Coupling plate	stainless steel
Base-frame	cement (ultra high performance concrete)
Ferrules and spacers	thermoplastic material

Piano e basamento	gres o cemento (ultra high performance concrete)
Piastra di aggancio	acciaio inox
Basamento	cemento (ultra high performance concrete)
Puntali e distanziali	materiale termoplastico

#### Tables Tavoli

OA155TQ\_6 - OA155TQ\_6G

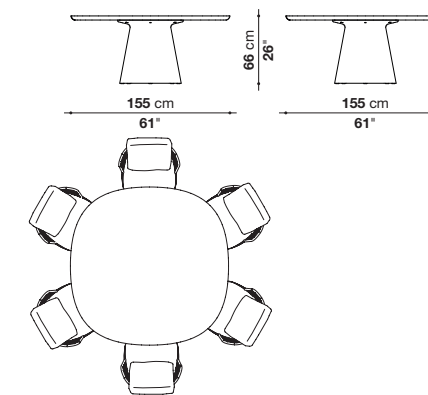

OA155TQ\_7 - OA155TQ\_7G

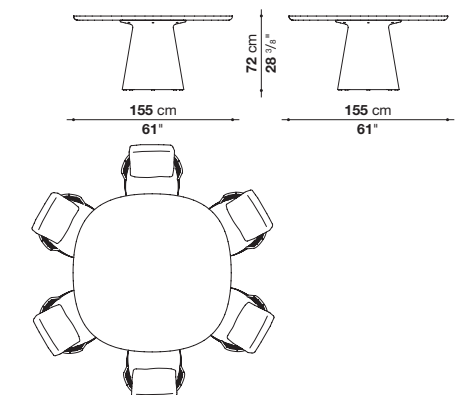

OA225T\_6 - OA225T\_6G

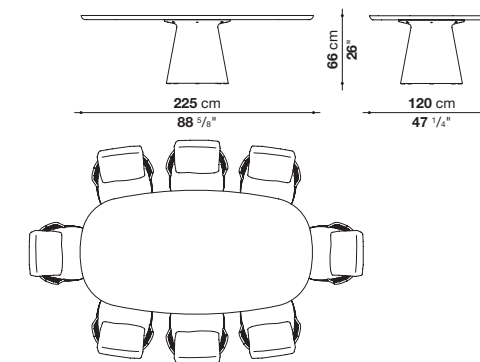

OA225T\_7 - OA225T\_7G

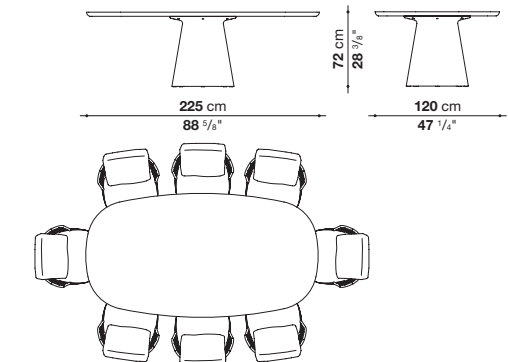

#### Base-Frame Basamento

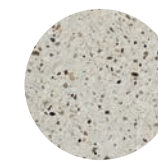

0237G  
grey cement  
cemento grigio

#### Top Piano

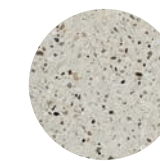

0237G  
grey cement  
cemento grigio

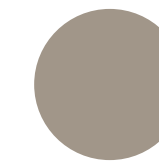

0613T  
glossy dove grey stonewear  
gres tortora lucido

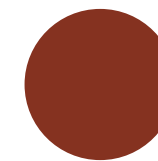

0784A  
glossy clay stonewear  
gres argilla lucido

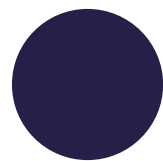

0829B  
glossy ocean blue stonewear  
gres blu oceano lucido

## Awa Outdoor

### Naoto Fukasawa • 2009

Inspiration • 312



A sculptural project by Naoto Fukasawa: the small table Awa Outdoor is a versatile object that can be used as a base for a lot of things. Base and top are integrated: aesthetically, it's the epitome of essential elegance. Awa is made with a technologically advanced material, a special blend of white Cristalplant Outdoor® that ensures it can be used both indoors and outdoors. Its particular surface is very soft, similar to natural stone.

Scultoreo progetto di Naoto Fukasawa: il tavolino Awa Outdoor è un oggetto versatile, di servizio, indispensabile per l'appoggio. Base e piano sono un unicuum: l'estetica si divide tra l'eleganza e l'essenzialità. Il materiale è tecnologicamente avanzato: lo compone una speciale miscela in Cristalplant Outdoor® bianco che assicura l'utilizzo in indoor così come in outdoor. La particolare superficie del materiale ha un effetto soft touch, simile alla pietra naturale.

Top and base-frame	Cristalplant Outdoor® (natural mineral filler of phosphate of aluminium with polyester acrylate resin)	Piano e basamento	Cristalplant Outdoor® (carica minerale naturale di idrato d'alluminio con resina poliestere acrilata)
Ferrules	thermoplastic material	Puntali	materiale termoplastico

#### Small table

##### Tavolino

TA1

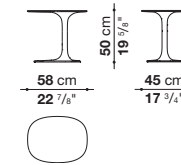

#### Top and base-frame

##### Piano e basamento

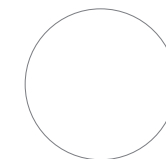

**0101G**  
white Cristalplant Outdoor®  
Cristalplant Outdoor® bianco

The colour shown are an indication.  
La tonalità del colore è indicativa.



## Ayana

### Naoto Fukasawa • 2020

Inspiration • 105



Minimalist and innovative, the Ayana collection becomes a new chapter in the story that connects B&B Italia to Naoto Fukasawa. It sees wood as the protagonist, interpreted in an unusual way, with a pleasant oriental touch. If the depths and heights are a clear reference to the south-east Asian tradition, the backrest recalls a Swedish wall bar, an exercise equipment turned into a load-bearing element. Thanks to this solution, the elements of the Ayana collection can be enjoyed and appreciated at 360 degrees, discovering on each side a new elegant interplay of intersections and proportions. Two and three seat sofas and the armchair have armrests at different heights. The armchair armrest is higher to guarantee a more ergonomic seat. The sofa armrest, which is lower, can be combined with a cushion that is easy to be fastened and removed, and helps to lie down more comfortably if necessary. The upholstery of this collection stands out for the individual cushions, all covered with waterproof fabrics.

Minimalista e innovativa, la collezione Ayana diventa un nuovo capitolo nella storia che lega B&B Italia a Naoto Fukasawa e che vede come protagonista il legno, interpretato in maniera insolita, con un piacevole tocco orientale. Se le profondità e le altezze sono un chiaro rimando alla tradizione del sud-est asiatico, lo schienale richiama una spalliera svedese, che da strumento per l'attività fisica si trasforma in elemento portante. Grazie a questa soluzione, gli elementi della collezione Ayana possono essere goduti e apprezzati a 360 gradi, scoprendo su ogni lato un nuovo elegante gioco di incroci e proporzioni. I divani, proposti nelle versioni a due e tre posti, e la poltrona si presentano con braccioli di diversa altezza. Il bracciolo della poltrona è più alto per garantire una seduta più ergonomica. Al bracciolo del divano, più basso, è possibile abbinare un cuscinetto facile da agganciare e rimuovere, che all'occorrenza consente di sdraiarsi agevolmente. Le imbottiture si contraddistinguono per i cuscini singoli, rivestiti da tessuti waterproof.



Ayana's warm minimalism is completed with a chair, a dining table and a low table. The dining chair recalls the stylistic features of the other seats, for a perfect family feeling, with the structure in natural teak wood and two generously padded cushions covered in fabric. The table stands out for its oval top in serpentine, a typical stone of the Alps. The supporting structure in natural teak appears light but is extremely robust, able to resist weather and support the heavy top. Even the coffee table has a round section structure in natural teak, with a top in serpentine. Its broad dimensions allow to create a pleasant convivial atmosphere in outdoor settings. Ayana is a project with a green soul. The teak used to make the structures is FSC® certified (Forest Stewardship Council) and all the materials that make up the various elements of the series, at the end of the product's life cycle, can be separated and disposed of with respect for the environment.

Il minimalismo caldo di Ayana si completa con una sedia, un tavolo da pranzo e un tavolo basso. La sedia richiama gli stilemi delle altre sedute, per un perfetto family feeling, con la struttura in teak naturale a sezione tonda e una generosa imbottitura a due cuscini rivestiti in tessuto. Il tavolo si contraddistingue per l'ovale del piano in serpentino, pietra tipica delle Alpi. La struttura portante in teak naturale appare leggera ma si rivela estremamente robusta, capace di resistere alle intemperie e sostenere l'importante superficie. Anche il tavolo basso presenta la struttura a sezione tonda in teak naturale, sormontata da un piano in serpentino. Le ampie dimensioni sono pensate per creare un ambiente conviviale e piacevole anche all'aperto. Ayana è un progetto dall'animo green. Il teak utilizzato per realizzare le strutture è certificato FSC® (Forest Stewardship Council) e tutti i materiali che compongono i vari elementi della serie, al termine del ciclo di vita del prodotto, potranno essere separati e smaltiti nel rispetto dell'ambiente.

## Ayana

### Naoto Fukasawa • 2020

Inspiration • 105

The entire collection is based on structures with a round section, a far cry from the traditional square section that defines many outdoor furnishings. As if they were made of sticks simply set next to one another, the Ayana structures are made of natural teak. The wood is unpainted to allow it to age and evolve in the most genuine way, respecting the intrinsic characteristics of this material. An ancestral choice that recalls ancient tools and primitive constructions, which however conceals ingenious technical solutions.

The structures are also distinguished by the presence of invisible joints that do not include metal elements such as screws, but only wooden pins. An aesthetic choice that is also a functional one: in fact, this allows the wood to continue its transformations as weather conditions change, without however causing irreversible cracking or deformation. In Fukasawa's vision, round sections and untreated wood create a more natural look that is completed with a seat style that is halfway between the Far East and contemporary Scandinavian.

L'intera collezione si basa su strutture a sezione tonda, lontane dalla tradizionale sezione quadrata che definisce larga parte dell'arredo outdoor. Come fossero fatte di bastoni semplicemente accostati, appoggiati a quota zero, le strutture di Ayana sono realizzate in teak naturale, non verniciato in modo da garantire al legno di maturare ed evolvere nella maniera più genuina, rispettando le caratteristiche intrinseche di questo materiale. Una scelta ancestrale, che ricorda strumenti antichi o magari costruzioni primitive, che tuttavia nasconde soluzioni tecniche di assoluto ingegno. Le strutture sono contraddistinte anche dalla presenza di incastri invisibili che non prevedono l'aggiunta di elementi metallici quali viti o giunti, ma soltanto spine di legno. Una scelta estetica, ma anche funzionale: infatti in questo modo si permette al legno di seguire naturalmente le sue trasformazioni al variare delle condizioni atmosferiche, senza però causare fessurazioni o deformazioni irreversibili. Nella visione di Fukasawa, sezione tonda e legno non trattato concorrono a creare un aspetto più naturale, che si completa con uno stile di seduta che si situa a metà strada tra Estremo Oriente e contemporaneo scandinavo.



## Ayana Naoto Fukasawa • 2020

Inspiration • 105

### TEAK WOOD

Teak wood comes from various tectona plants that are common in tropical countries. As a result of its strong resistance to humidity and of its internal content of oily substances, it is considered a very precious wood type especially for outdoor environments.

It must be said that wood is a living material that reacts to external agents; hence, it is normal and natural to note a variation in the shade of colour as time goes by.

The change in colour over time is not a defect.

On the contrary, it is a natural characteristic of this wood that lives and reacts to the outside environment with an aging/oxidation process which does not alter the structural integrity of the product. The images on the right show an example of how the colour of the wood surface can vary.

Il legno di Teak proviene da diverse piante di tectona diffuse nei paesi tropicali. Ha eccellenti caratteristiche di resistenza agli agenti atmosferici, alla salsedine, all'umidità e alle escursioni termiche grazie alla presenza al suo interno di una resina oleosa. Il legno è comunque un materiale vivo che reagisce agli agenti esterni; una esposizione continua ad essi muta progressivamente lo strato superficiale fino alla formazione di una patina superficiale grigio/argento. Tale fenomeno non è quindi da considerarsi un difetto ma la testimonianza della naturalità del legno che vive e reagisce all'ambiente esterno con un processo di maturazione/ossidazione che non altera in alcun modo l'integrità strutturale del prodotto. L'immagine a lato riporta un esempio di variazione della colorazione della superficie del legno.

### SERPENTINE STONE

The Serpentine of Valmalenco is an ornamental stone used for both construction and furnishing. It is quarried by natural splitting or in blocks and has physical and aesthetic properties that render it both highly prized and extremely durable. Thanks to its physical and aesthetic properties, it is perfect for interior and exterior cladding of buildings, lining stoves and furnishings. With its fine grain and marked foliation, natural split serpentine is processed mainly into sheets of varying thicknesses.

Il serpentino della Valmalenco è una pietra ornamentale e da costruzione utilizzata in edilizia e nell'arredamento. E' coltivato sia nella varietà a spacco sia in quella massiccia, e possiede caratteristiche fisiche ed estetiche che lo rendono estremamente durevole e pregiato. Grazie alle sue proprietà fisiche e qualità estetiche, trova naturale impiego nella realizzazione di rivestimenti di stufe, esterni e interni di edifici e complementi d'arredo. Il serpentino a spacco, in virtù della sua grana molto fine e della marcata foliazione, viene lavorato prevalentemente in lastre di vario spessore, leggere e impermeabili.



2602407

Linaria

2485207

Lipari

2602207

Linaria

0408S

Serpentine stone

Pietra Serpetino

0456T

Natural teakwood

Teak naturale



# Ayana

## Naoto Fukasawa • 2020

Inspiration • 105

Sofas  
Divani

AY210

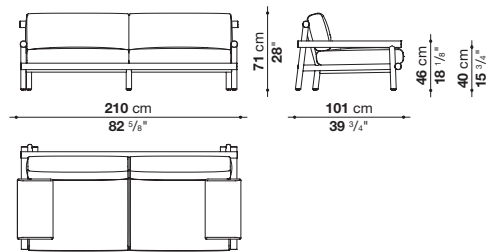

AY263

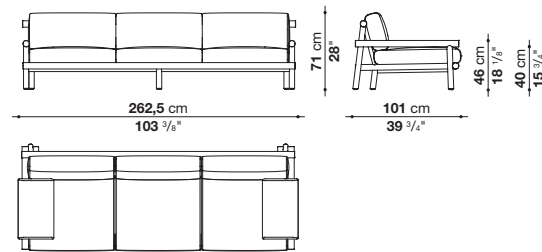

Armchair  
Poltrona

AY86P

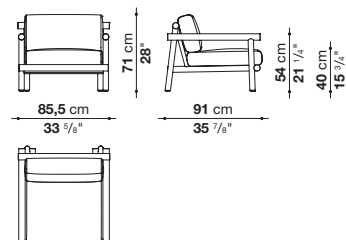

Chair  
Sedia

AY58S

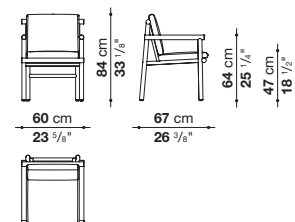
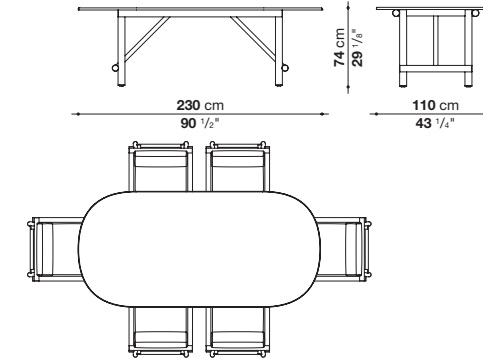

Table  
Tavolo

TAY230



Low table  
Tavolo basso

TAY180

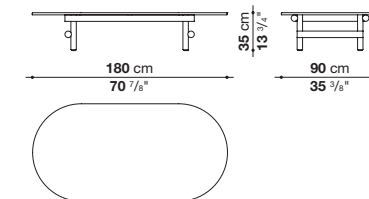

# Ayana

## Naoto Fukasawa • 2020

Inspiration • 105

Frame	solid wood
Upholstery	shaped polyurethane, cover in water repellent polyester fibre
Top (TAY230-TAY180)	Serpentine stone
Ferrules	thermoplastic material
Waterproof cover cloth	PES fabric coated on one side in PU
Cover	fabric in limited categories

Struttura	legno massello
Imbottitura	poliuretano sagomato, fodera in fibra di poliestere con trattamento idrorepellente
Piano (TAY230-TAY180)	pietra Serpentino
Puntali	materiale termoplastico
Telo di copertura impermeabile	tessuto PES monospalmato su un lato PU
Rivestimento	tessuto in categorie limitate

### Product items/Prodotti

#### Recommended combinations/Abbinamenti suggeriti



2602207  
Linaria



2485207  
Lipari



0456T  
natural teakwood  
teak naturale



2603207  
Liri



0456T  
natural teakwood  
teak naturale



2485207  
Lipari



0456T  
natural teakwood  
teak naturale



2485407  
Lipari



0456T  
natural teakwood  
teak naturale



2485830  
Lipari



0456T  
natural teakwood  
teak naturale



2485830  
Lipari



0408S  
Serpentine  
stone  
pietra  
Serpentino



0456T  
natural teakwood  
teak naturale

#### Frame Struttura



0456T  
natural teakwood  
teak naturale

#### Table and low table top Piano tavolo e tavolo basso

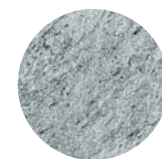

0408S  
Serpentine stone  
pietra Serpentino

## Bay

Nipa Doshi and Jonathan Levien • 2018

Inspiration • 231



Bay is a collection of sculptural and monolithic yet visually light outdoor seats comprising of a sofa in two sizes, an armchair and a high-backed armchair. Their enveloping volumes are marked by a double polypropylene fibre interlacing that creates “air pockets”, granting transparency and lightness to the furniture. The frame accommodates padded solid seats and soft cushions for added comfort. The colours combinations are extremely refined, with tortora and anthracite for the interlacing, paired with elegant block colour and patterned fabrics for the seats and cushions.

Bay è una collezione di sedute da esterno composta da divano in due dimensioni, poltrona e poltrona con schienale alto, che si distinguono per l'aspetto scultoreo monolitico, al contempo visivamente leggero. Avvolgenti volumi intrecciati realizzati in fibra di polipropilene, con un doppio intreccio che crea “tasche d'aria” che donano trasparenza e leggerezza, sono combinati con sedute imbottite dalle sembianze di rocce e si completano con morbidi cuscini che offrono grande comfort. Ricercata la proposta cromatica che prevede due colori per l'intreccio, tortora e antracite, da abbinare alle raffinate tonalità di tessuti tinta unita e fantasia previsti per i rivestimenti di sedute e cuscini.

## Bay

Nipa Doshi and Jonathan Levien • 2018

Inspiration • 231



In 2019 the Bay collection has seen the addition of a sofa, a small armchair and an ottoman that reinforce the iconic image of the range by mirroring the generous and solid shapes and the sense of transparency generated by the interplay of anthracite-and dove-coloured polypropylene interlacing. The new sofa has a particularly welcoming and deep seat, complemented by soft seat-back cushions and new roller cushions that can be used as headrests. The small armchair is a scaled-down version of the existing armchair providing a perfect addition to the collection, or an alternative for smaller spaces. The new ottoman mirrors the chair design and coordinates with the whole range.

La collezione Bay si arricchisce nel 2019 di un divano, una poltroncina e un pouf che confermano l'iconicità della famiglia, riprendendone i volumi ampi e monolitici e le trasparenze create dai sofisticati giochi di intrecci in polipropilene antracite e tortora. Il nuovo divano presenta una seduta particolarmente accogliente e profonda, completata da morbidi cuscini schienale e dai nuovi cuscini rullo da utilizzare come poggiatesta. La poltroncina riproduce in scala ridotta le poltrone già in collezione, diventando così una perfetta aggiunta oppure un'alternativa per spazi più ridotti. Nuovo anche il pouf che riprende il disegno delle sedute e si coordina con tutti gli elementi della serie.

## Bay

Nipa Doshi and Jonathan Levien • 2018  
Inspiration • 231

Sofas  
Divani

BY176

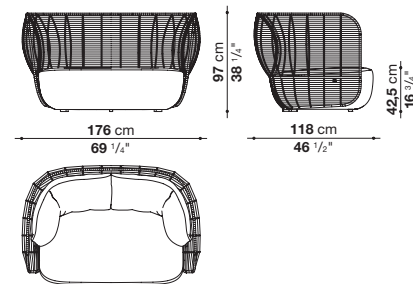

BY176CL

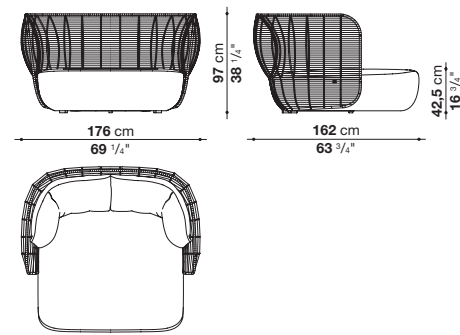

BY236

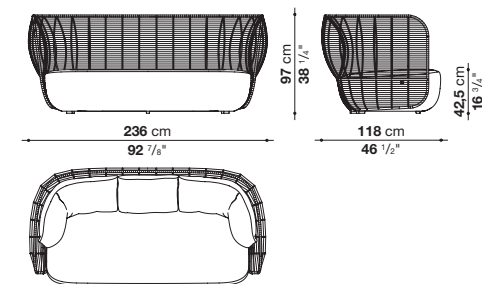

Small armchairs  
Poltroncina

BY94N

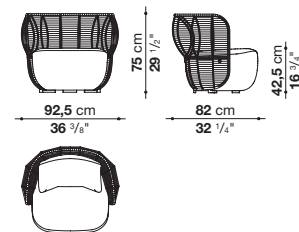

Armchairs  
Poltrone

BY118B

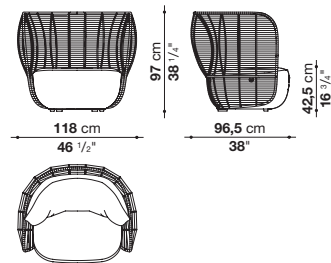

BY123A

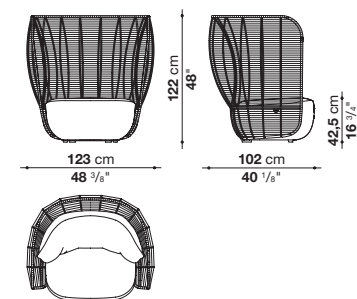

Ottoman  
Pouf

BY74PQ

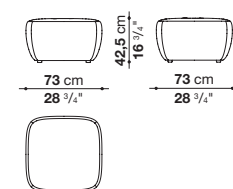

Internal frame	tubular steel and steel profiles	Telaio interno	tubolari e profilati d'acciaio
Back frame	aluminium	Telaio schienale	alluminio
Upholstery	Bayfit® (Bayer®) flexible cold shaped polyurethane foam, water repellent polyester fibre cover (with heat-sealed ribbon)	Imbottitura	schiuma di poliuretano flessibile a freddo Bayfit® (Bayer®), fodera in fibra di poliestere con trattamento idrorepellente (con cuciture termosaldate)
Back cushion	Solotex fibre and visco-elastic polyurethane combination, cover in water repellent polyester fibre	Cuscino schienale	combinazione fibra Solotex e poliuretano viscoelastico, fodera in fibra di poliestere con trattamento idrorepellente
Interlacing	polypropylene fibre braid	Intreccio	treccia in fibra di polipropilene
Feet and ferrules	thermoplastic material	Piedini e puntali	materiale termoplastico
Waterproof cover cloth	PES fabric coated on one side in PU	Telo di copertura impermeabile	tessuto PES monospalmato su un lato PU
Cover	fabric in limited categories	Rivestimento	tessuto in categorie limitate

Frame and interlacing matching  
Abbinamento struttura e intreccio



0158A  
anthracite painted - anthracite polypropylene  
verniciato antracite - polipropilene antracite



0833T  
tortora painted - tortora polypropylene  
verniciato tortora - polipropilene tortora

The colours and materials shown are an indication. Images not in scale.  
La tonalità dei colori e dei materiali è indicativa. Immagini non in scala.



# Bay

Nipa Doshi and Jonathan Levien • 2018  
Inspiration • 231

2558877  
Samos

2481877  
Lesia

2481400  
Lesia

2481251  
Lesia

2481255  
Lesia

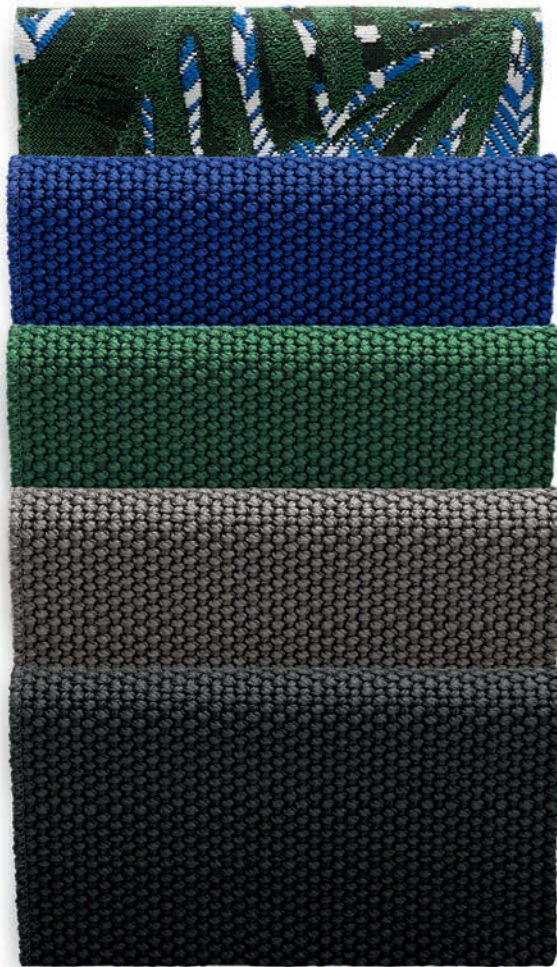

## Product items/Prodotti Recommended combinations/Abbinamenti suggeriti



2481877  
Lesia



2558877  
Samos



0158A  
anthracite painted  
anthracite polypropylene  
verniciato antracite  
polipropilene antracite



2481877  
Lesia



2558877  
Samos



0158A  
anthracite painted  
anthracite polypropylene  
verniciato antracite  
polipropilene antracite



2481255  
Lesia



2485255  
Lipari



0158A  
anthracite painted  
anthracite polypropylene  
verniciato antracite  
polipropilene antracite



2481400  
Lesia



2558877  
Samos



0158A  
anthracite painted  
anthracite polypropylene  
verniciato antracite  
polipropilene antracite



2481280  
Lesia



2570415  
Elisir



2570420  
Elisir



0833T  
tortora painted  
tortora polypropylene  
verniciato tortora  
polipropilene tortora



2481280  
Lesia



2570420  
Elisir



0833T  
tortora painted  
tortora polypropylene  
verniciato tortora  
polipropilene tortora

## Borea

Piero Lissoni • 2021-2022

Inspiration • 81



Borea is a complete and eclectic collection of outdoor seats and tables designed by Piero Lissoni. The numerous pieces in the collection have in common tubular metal structures with a fluid and seamless design, without joints and interruptions, captivating and even emerging in the detail that extends to the base. The metal bending processes take advantage of techniques typically used in the aeronautical sector and transport them into the world of outdoor furniture bringing life to a collection with an unmistakable style.

Borea è una collezione completa ed eclettica di sedute e tavoli da esterni disegnata da Piero Lissoni. I numerosi pezzi che la compongono sono accomunati da strutture in metallo tubolare dal disegno fluido e continuo, senza giunti e interruzioni, accattivante e addirittura sorprendente nella parte terminale che appoggia a terra. Le lavorazioni di piegatura e curvatura del metallo riprendono tecniche tipicamente utilizzate nel settore aeronautico e le trasportano nel mondo dell'arredo outdoor dando vita ad una collezione dalla cifra stilistica inconfondibile.

The collection includes two- and three-seater sofas, an oversized armchair, a low small armchair and a dining chair, all with stackable aluminum structures painted in dove grey, sage, clay and anthracite colours. Comfort is ensured by generous cushions, which are not only soft and relaxing but were also developed to be sustainable. Paddings are in fact made with polyester fiber filling coming from recycled PET plastic bottles enveloping a different densities polyurethane core.

Le sedute comprendono divani a due e tre posti, una poltrona dalle proporzioni importanti, una poltroncina bassa e una poltroncina pranzo, tutte con strutture impilabili in alluminio verniciato nei colori tortora, salvia, argilla e antracite. Il comfort è assicurato da cuscinate super generose e accoglienti, all'insegna della morbidezza, del relax e della sostenibilità. Le imbottiture sono infatti realizzate in fibra 100% poliestere proveniente dal riciclo di bottiglie in plastica PET che avvolge un inserto in poliuretano a densità differenziata.

## Borea

Piero Lissoni • 2021-2022

Inspiration • 81



A delicate balance of oval shapes defines the essence of the Borea sunbed lounge, a seat with great character. Available in two versions: chaise lounge and sofa, both featuring a large section of reclinable back. The chaise lounge has an elongated, welcoming form just right for one or two people. By lowering the back, the chaise longue becomes an island with multiple uses. The same is true of the sofa, with construction and structural features that are perfect for the pool, the lawn, or even the terrace. The frame is made of curved aluminium tubes and is completed with an upholstered mattress that guarantees great comfort.

Un delicato equilibrio di forme ovali definisce l'essenza di Borea lounge sunbed, una seduta di grande carattere proposta in due versioni: chaise longue e divano, entrambe caratterizzate da uno schienale regolabile in tre posizioni. La chaise longue si definisce con una forma allungata e accogliente, adatta a ospitare una o due persone. Abbassando lo schienale la chaise longue diventa un'isola dai molteplici usi. Lo stesso accade con il divano, che per le sue caratteristiche costruttive e strutturali risulta perfetto per la piscina, su un prato oppure in terrazza. La struttura è realizzata in alluminio tubolare curvato ed è completata da un materassino imbottito che offre grande comodità.

## Borea

Piero Lissoni • 2021-2022

Inspiration • 81

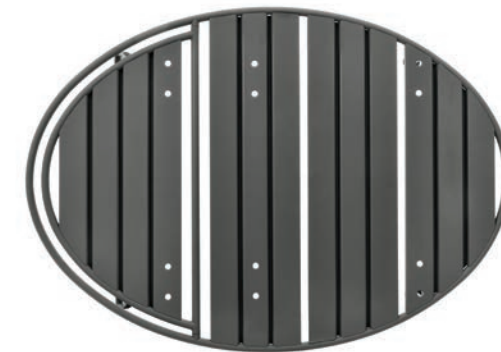
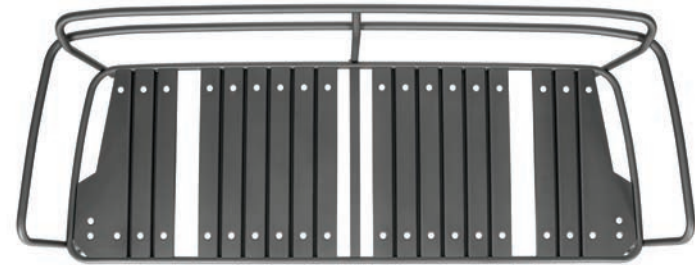

Stackable products  
Prodotti impilabili

The starting point of the seating collection are lightweight tubular aluminium structures that combine a fluid, continuous design with functionality and sustainability. The starting point of the seating collection are lightweight tubular aluminium structures that combine a fluid, continuous design with functionality and sustainability.

Aluminium's lightness combined with a well thought-out design allows the structures to be easily stacked so that they can be stored during winter in the smallest space. It is possible to stack up to three armchairs, three two-seater sofas, three three-seater sofas, six chairs and six small armchairs.

Punto di partenza della collezione di sedute sono strutture leggere in tubolare d'alluminio che combinano un disegno fluido e continuo a contenuti di funzionalità e sostenibilità. L'alluminio rappresenta infatti una scelta sostenibile sia perché estremamente resistente e durevole sia perché interamente e facilmente riciclabile, quindi riutilizzabile all'infinito per dare vita

ogni volta a nuovi prodotti. La leggerezza dell'alluminio unita al design studiato nei minimi dettagli consente inoltre di impilare le strutture agevolmente così da poterle riporre durante la stagione invernale occupando il minor spazio possibile. È possibile impilare fino a 3 poltrone, 3 divani a due posti, 3 divani a tre posti, 6 sedie e 6 poltroncine.

# Borea

Piero Lissoni • 2021-2022

Inspiration • 81

Sofas  
Divani

BE175

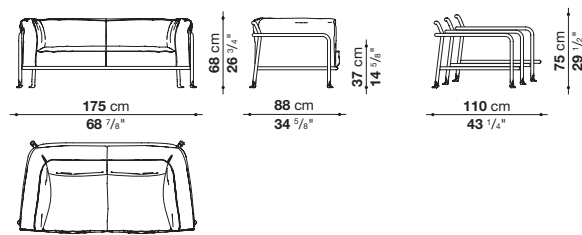

BE243

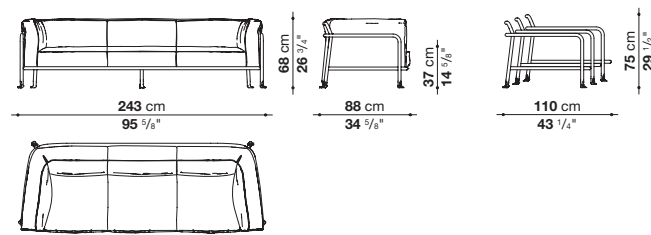

Oval sunbeds  
Lettini ovali

BE150L

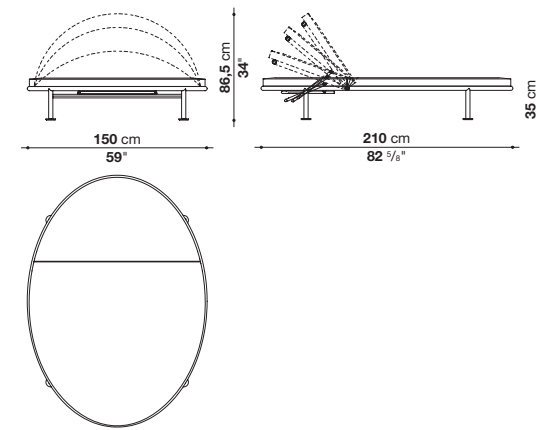

BE210L

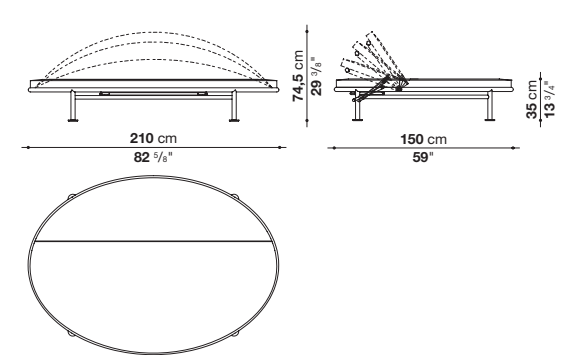

Armchair  
Poltrona

BE1018

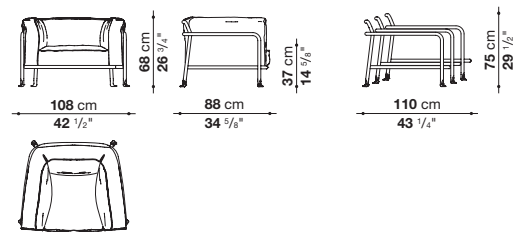

Small armchair  
Poltroncina

BE69PB

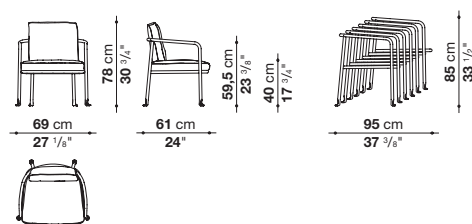

Chair  
Sedia

BE69PA

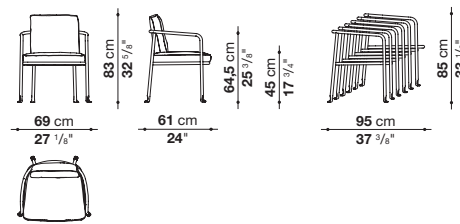

# Borea

## Piero Lissoni • 2021-2022

Inspiration • 81

Frame	tubular and aluminium sheet
Upholstery	shaped polyurethane of different density, polyester fibre
Ferrules	thermoplastic material
Waterproof cover cloth	PES fabric coated on one side in PU
Cover	fabric in limited categories (with profile)

Struttura	tubolare e lamiera d'alluminio
Imbottitura	poliuretano sagomato a densità differenziata, fibra di poliestere
Puntali	materiale plastico
Telo di copertura impermeabile	tessuto PES monospalmato su un lato PU
Rivestimento	tessuto in categorie limitate (con profilo)

### Profile Profilo

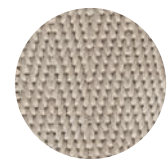

0041E  
cream white  
bianco panna



0082N  
natural  
naturale

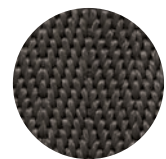

0054G  
dark grey  
grigio scuro

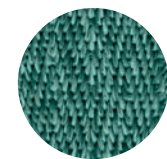

00585A  
acquamarine  
acquamarina

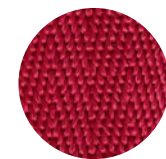

0075R  
red  
rosso

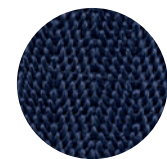

0095B  
blue  
blu

### Frame Struttura

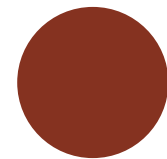

0750A  
clay painted  
verniciato argilla



0427S  
sage painted  
verniciato salvia

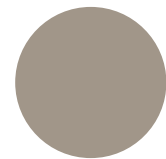

0380T  
tortora painted  
verniciato tortora

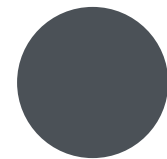

0236B  
anthracite painted  
verniciato antracite

The colours and materials shown are an indication. Images not in scale.  
La tonalità dei colori e dei materiali è indicativa. Immagini non in scala.

### Product items/Prodotti Recommended combinations/Abbinamenti suggeriti



2563810  
Agate



0085A  
acquamarine profile  
profilo acqua marina



0236B  
anthracite painted  
verniciato antracite



2620102  
Aliseo



0095B  
blu profile  
profilo blu



0380T  
tortora painted  
verniciato tortora



2620102  
Aliseo



2818210  
Solano



2818215  
Solano



0041E  
cream white profile  
profilo bianco panna



0236B  
anthracite painted  
verniciato antracite



2818210  
Solano



0054G  
dark grey profile  
profilo grigio scuro



0750A  
clay painted  
verniciato argilla



2818815  
Solano



0095B  
blue profile  
profilo blu



0236B  
anthracite painted  
verniciato antracite



2620102  
Aliseo



0075R  
profilo rosso  
red profile



0750A  
clay painted  
verniciato argilla



2818815  
Solano



0095B  
blue profile  
profilo blu



0236B  
anthracite painted  
verniciato antracite

The colours and materials shown are an indication. Images not in scale.  
La tonalità dei colori e dei materiali è indicativa. Immagini non in scala.

## Borea

### Piero Lissoni • 2021-2022

Inspiration • 81

Frame	tubular and aluminium sheet
Upholstery	shaped polyurethane of different density, polyester fibre
Ferrules	plastic material
Waterproof cover cloth	PES fabric coated on one side in PU
Cover	fabric in limited categories

Struttura	tubolare e lamiera d'alluminio
Imbottitura	poliuretano sagomato a densità differenziata, fibra di poliestere
Puntali	materiale plastico
Telo copertura	tessuto PES monospalmato su un lato in PU
Rivestimento	tessuto in categorie limitate

#### Product items/Prodotti

#### Recommended combinations/Abbinamenti suggeriti



2821895  
Lamone



2820811  
Lilia



2820100  
Lilia



0750A  
clay painted  
verniciato argilla



2821895  
Lamone



2820811  
Lilia



2820100  
Lilia



0380T  
dove grey painted  
verniciato tortora

#### Frame

#### Struttura

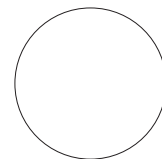

0186V  
white painted  
verniciato bianco

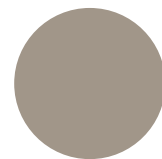

0380T  
dove grey painted  
verniciato tortora

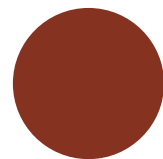

0750A  
clay painted  
verniciato argilla

## Borea

Piero Lissoni • 2021-2022

Inspiration • 81



The dining tables reflect the design and shades of the seating structures, but use steel instead of aluminum to support distinctive tops in teak and glazed lava stone. The lava stone comes from the slopes of Mount Etna (Sicily, Italy) and is available in large rectangular tiles in three bright colors - sage, clay and ocean blue - which harmonize perfectly with the whole collection. The glazed surface is made with a special material obtained by recycling the glass of discarded TV and PC monitors, applied directly to the stone through an exclusive manufacturing process. The tables are available in two sizes to accommodate six and eight people respectively: 244x105 cm and 285x105 cm.

I tavoli da pranzo riprendono il disegno e le tonalità delle strutture delle sedute, ma utilizzano l'acciaio al posto dell'alluminio per sostenere piani importanti in teak e in pietra lavica proveniente dalle pendici dell'Etna. Quest'ultima è interpretata con grosse piastrelle rettangolari smaltate in tre colori brillanti - salvia, argilla e blu oceano - che si armonizzano perfettamente con tutta la collezione. La superficie smaltata è realizzata con un materiale speciale ottenuto dal recupero del vetro di monitor di tv e pc dismessi, applicato direttamente alla pietra tramite un esclusivo processo di lavorazione. Due le dimensioni per ospitare rispettivamente sei e otto persone: cm 244x105 e cm 285x105.



The low tables designed to complement the sofas and chairs have the same tops composed of glazed lava stone tiles. They are available in two sizes - 121x105 cm and 162x105 cm - with structures in steel rod painted in dove grey, sage, clay and anthracite. The collection is enriched and completed by a series of round tables that offer multiple support solutions. The Borea coffee tables, in three sizes and heights, have thin structures in dove-gray, sage, clay and anthracite painted steel rod and are available with tops in glazed lava stone in sage, clay and ocean blue colors.

Il motivo del piano con piastrelle in pietra lavica smaltata è ripreso da tavoli bassi pensati come complemento per le sedute. Sono proposti in due dimensioni - cm 121x105 e cm 162x105 - con strutture in tondino di acciaio verniciato tortora, salvia, argilla e antracite. Ad arricchire e completare la collezione una serie di tavolini tondi che offrono molteplici soluzioni di appoggio. I tavolini Borea, in tre misure e altezze, hanno strutture sottili in tondino di acciaio verniciato tortora, salvia, argilla e antracite e prevedono piani in pietra lavica smaltata salvia, argilla e blu oceano.



**Borea**  
Piero Lissoni • 2021-2022  
Inspiration • 81

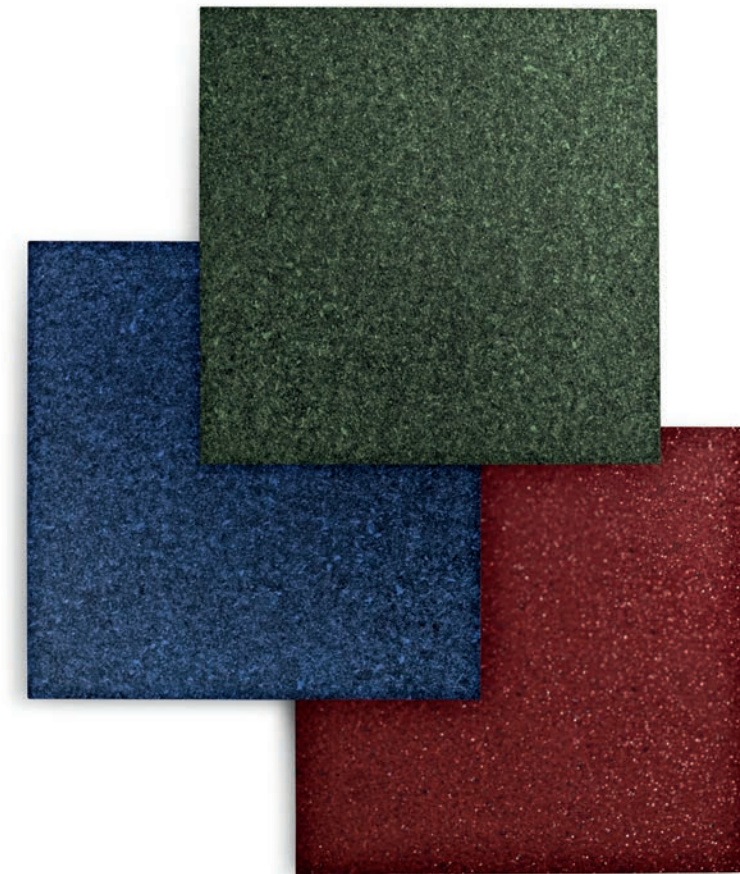

## Borea

### Piero Lissoni • 2021-2022

Inspiration • 81

Frame	tubular stainless steel
Top	enamelled lava stone
Ferrules and spacers	plastic material
Waterproof cover cloth	PES fabric coated on one side in PU

Struttura	tubolare d'acciaio inox
Piano	pietra lavica smaltata
Puntali e distanziali	materiale plastico
Telo di copertura impermeabile	tessuto PES monospalmato su un lato PU

#### Top Piano

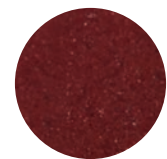

0032A  
clay enamelled lava stone  
pietra lavica smaltata argilla

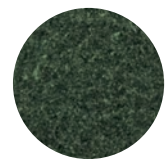

0057S  
sage enamelled lava stone  
pietra lavica smaltata salvia

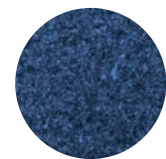

0097B  
ocean blue enamelled lava stone  
pietra lavica smaltata blu oceano

#### Frame Struttura

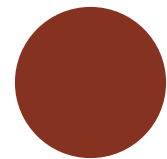

0750A  
clay painted  
verniciato argilla



0427S  
sage painted  
verniciato salvia

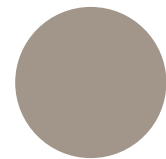

0380T  
tortora painted  
verniciato tortora

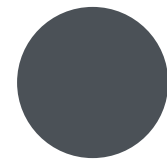

0236B  
anthracite painted  
verniciato antracite

The colours and materials shown are an indication. Images not in scale.  
La tonalità dei colori e dei materiali è indicativa. Immagini non in scala.

#### Tables Tavoli

##### TBE244

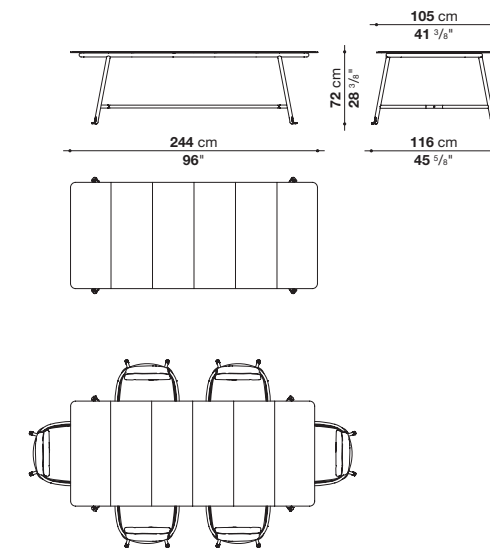

##### TBE285

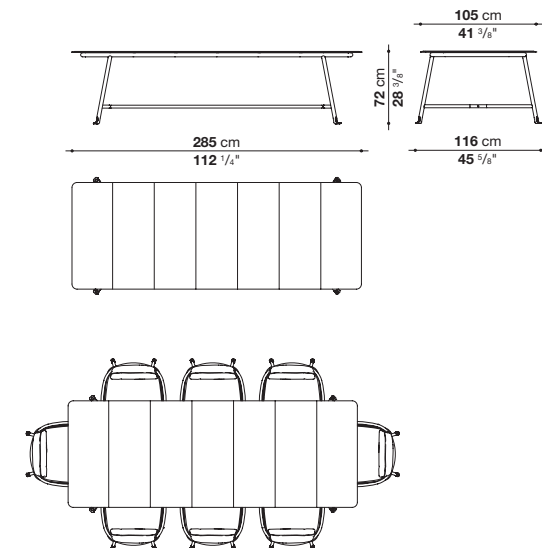

#### Low tables Tavoli bassi

##### TBE121

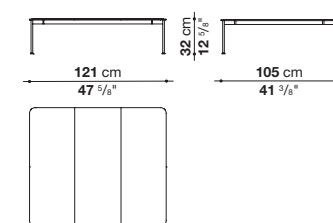

##### TBE162

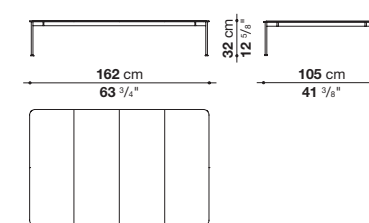

#### Round small tables Tavolini rotondi

##### TBE4

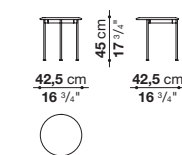

##### TBE6

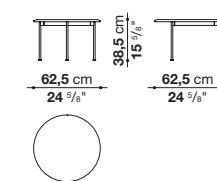

##### TBE8

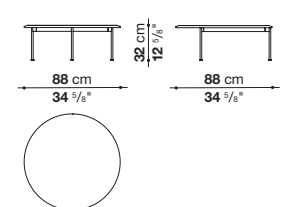

## Butterfly

Patricia Urquiola • 2015

Inspiration • 245



Butterfly gets its name from the “butterfly” shape created by the outer corner that joins the armrest and the backrest. It is a modular seating system that responds effectively to the needs of modularity and comfort, suitable for free and informal usage. Its modular structure is shaped around an ottoman, which is the base piece, and which, when integrated with the backrest and/or the armrest, becomes a central or terminal element, either left or right. The combination of these elements, using a simple joint system, makes it possible to freely set up versatile configurations, from in-line sofas to corner solutions, from front facing to lounge layouts.

Butterfly prende il suo nome dalla forma a “farfalla” che disegna l’angolo esterno di unione tra bracciolo e schienale. È un sistema di sedute componibili che risponde in modo efficace ad esigenze di modularità e comfort, proponendo un utilizzo libero e informale. La struttura modulare si sviluppa intorno ad un pouf, il pezzo base, che integrato con schienale e/o bracciolo diventa poi un elemento centrale o terminale, destro o sinistro. Dall’accostamento tra questi elementi, tramite un semplice sistema di giunzione, nascono configurazioni libere e versatili, dai divani lineari a soluzioni angolari, da un accostamento vis-à-vis a soluzioni lounge.

The Butterfly complements have an outline that perfectly follows the lines of the sofa, harmoniously flanking the seat at the top. The family consists of two low tables and two small table featuring a large weave pattern, made of tortora coloured twisted polyethylene fibres that wraps around the grey painted aluminium frame. The surface of the complements is available in white Carrara marble “venatino statuarietto”.

I complementi Butterfly presentano una silhouette che riprende perfettamente l’andamento della struttura del divano, affiancandosi poi armoniosamente alla seduta nella parte alta. La famiglia si compone di due tavoli bassi e due tavolini caratterizzati da un intreccio grafico a dimensioni macro, realizzato con fibre di polietilene ritorte di color tortora, che avvolge la struttura in alluminio con finitura verniciato grigio. Il piano dei complementi è proposto in marmo bianco di Carrara “venatino statuarietto”.

## Butterfly

### Patricia Urquiola • 2015

Inspiration • 245

#### Terminal elements

Elementi terminali

BT112S

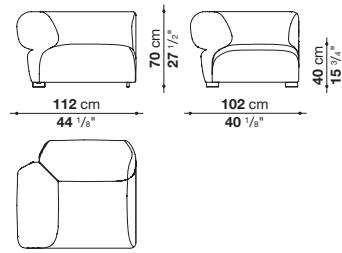

BT112D

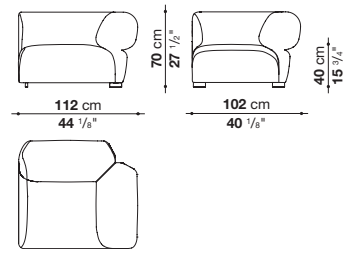

#### Central element

Elemento centrale

BT90C

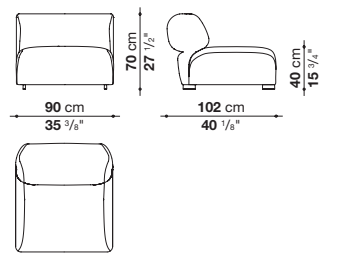

#### Ottoman

Pouf

BT90P

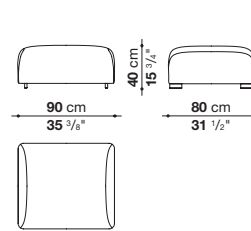

#### Small tables

Tavolini

BT7

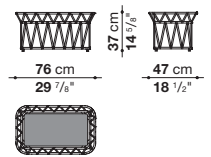

BT7Q

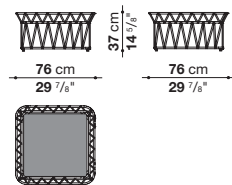

BT9R

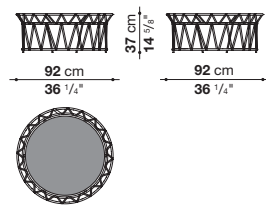

#### Low table

Tavolo basso

BT15

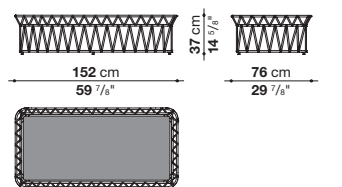

Internal frame	tubular steel and steel profiles	Telaio interno	tubolari e profilati d'acciaio
Internal frame upholstery	Bayfit® (Bayer®) flexible cold shaped polyurethane foam, water repellent polyester fibre cover (with heat-sealed ribbon)	Imbottitura telaio interno	schiuma di poliuretano flessibile a freddo Bayfit® (Bayer®), fodera in fibra di poliestere con trattamento idrorepellente (con cuciture termosaldate)
Frame (BT7-BT7Q-BT9R-BT15)	aluminium with polyester powder painting	Struttura (BT7-BT7Q-BT9R-BT15)	alluminio con verniciatura a polvere poliestere
Interlacing (BT7-BT7Q-BT9R-BT15)	polyethylene fibre	Intreccio (BT7-BT7Q-BT9R-BT15)	fibra di polietilene
Top (BT7-BT7Q-BT9R-BT15)	marble (natural finish)	Piano (BT7-BT7Q-BT9R-BT15)	marmo (finitura naturale)
Feet, ferrules and fixing elements	thermoplastic material	Piedini, puntali ed elementi di fissaggio	materiale termoplastico
Waterproof cover cloth	PES fabric coated on one side in PU	Telo di copertura impermeabile	tessuto PES monospalmato su un lato PU
Cover	fabric in limited categories	Rivestimento	tessuto in categorie limitate

#### Interlacing

Intreccio



0612T  
tortora polyethylene  
polietilene tortora

#### Small tables top

Piano tavolini

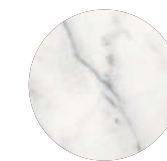

0900M  
natural Carrara white  
"venatino statuarietto" marble  
marmo bianco Carrara  
venatino statuarietto" naturale

The colours and materials shown are an indication. Images not in scale.  
La tonalità dei colori e dei materiali è indicativa. Immagini non in scala.

## Canasta

Patricia Urquiola • 2007

Inspiration • 259



The inspiration? A wicker basket in the Far East: Patricia Urquiola started working on the weave of Canasta (basket in Spanish) while out in the Far East. To find the perfect weave, the designer reinterpreted the traditional design of the octagonal holes in Viennese cane, mixed two patterns to transform the product into the macro-pattern of Canasta and create a series of outdoor sofas that look classic but have contemporary adaptability. In fact, the play between classic and contemporary is not a new idea: the Viennese cane inspiration is retro, and the polyethylene texture speaks today's language.

L'ispirazione? Una cesta in vimini vista in Estremo Oriente: Patricia Urquiola inizia da qui il lavoro sull'intreccio di Canasta (cesta, in spagnolo). Per trovare la trama perfetta la designer reinterpreta anche il tipico disegno a fori ottagonali della paglia di Vienna, mixa i due segni e li trasforma nel macro pattern geometrico di Canasta creando una serie di divani da giardino dalla memoria classica ma con plasticità contemporanea. Infatti il gioco tra il classico e il contemporaneo è senza alcuna nostalgia: se l'ispirazione alla paglia di Vienna è retro, la texture in polietilene parla il linguaggio di oggi.

A family of seating featuring a maxi-interlacing of white polyethylene fibre ribbon. There are many typologies: circular and linear sofas, armchairs and service elements. All these very comfortable seating have frames in aluminium with weather resistant polyester powder painting with interlacing in polyethylene fibre.

Famiglia di sedute caratterizzata dal macro-intreccio di nastri in fibra di polietilene bianca. Molteplici le tipologie: divani circolari e lineari, poltrone ed elementi di servizio. Tutte le sedute di grande comfort hanno la struttura in alluminio verniciato a polvere poliestere resistente agli agenti atmosferici e intreccio in fibra di polietilene.

# Canasta

## Patricia Urquiola • 2007

Inspiration • 259

Sofas  
Divani

CN190B

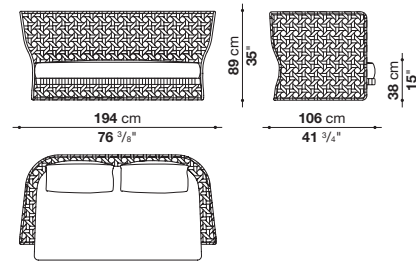

CN226B

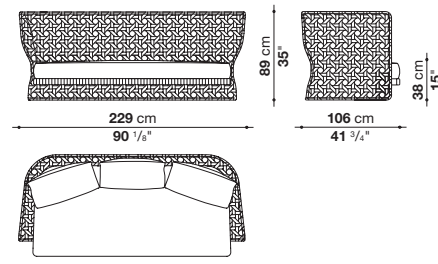

Armchairs  
Poltrone

CN98PB

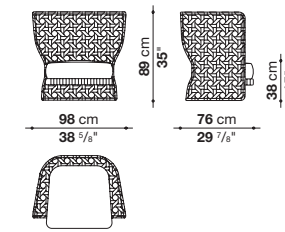

CN98PA

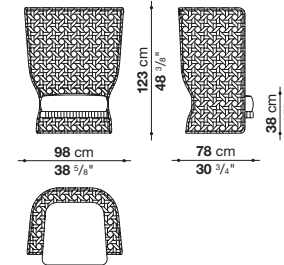

CN160P1

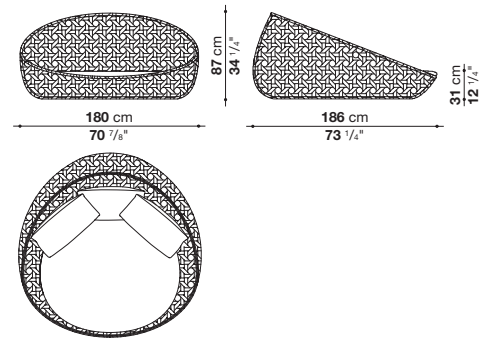

CN160P1, CN160P1W, CN160P1C

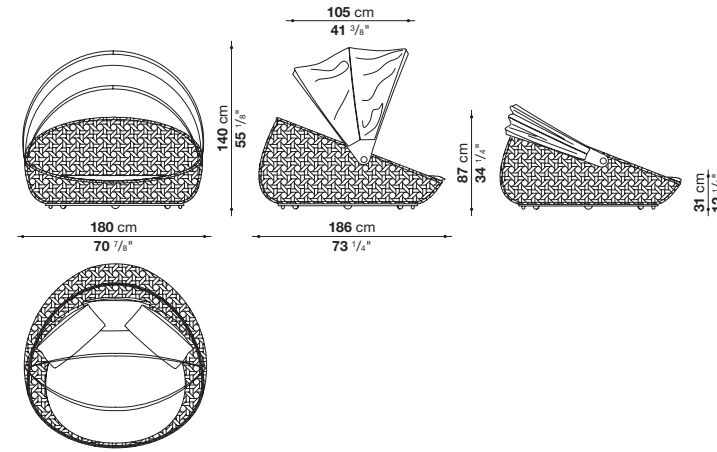

Service elements  
Elementi di servizio

PCN60

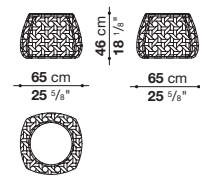

PCN80

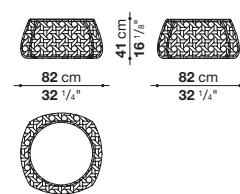

PCN110

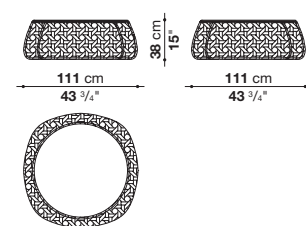

## Canasta

### Patricia Urquiola • 2007

Inspiration • 259

Frame	aluminium or steel with polyester powder painting
Interlacing	polyethylene fibre
Seat cushion (CN190B-CN226B-CN98PB-CN98PA)	shaped polyurethane, cover in water repellent polyester fibre (with heat-sealed ribbon)
Seat cushion (CN160P1)	shaped polyurethane, cover in water repellent polyester fibre
Back cushion	polyester fibre, cover in water repellent polyester fibre
Canopy frame (CN160P1C)	glass fibre
Canopy mechanism (CN160P1C)	electro polished steel, anodized aluminium
Canopy cover (CN160P1C)	Batik fabric
Wheels (CN160P1W)	plastic material, elastomeric polyurethane, electro polished stainless steel pin
Service element tray (PCN60-PCN80-PCN110)	steel sheet with polyester powder painting
Ferrules	thermoplastic material
Waterproof cover cloth	PES fabric coated on one side in PU
Cover	fabric in limited categories

Struttura	alluminio o acciaio con verniciatura a polvere poliestere
Intreccio	fibra di polietilene
Cuscino sedile (CN190B-CN226B-CN98PB-CN98PA)	poliuretano sagomato, fodera in fibra di poliestere con trattamento idrorepellente (con cuciture termosaldate)
Cuscino sedile (CN160P1)	poliuretano sagomato, fodera in fibra di poliestere con trattamento idrorepellente
Cuscino schienale	fibra di poliestere, fodera in fibra di poliestere con trattamento idrorepellente
Struttura capote (CN160P1C)	vetroresina
Meccanismo capote (CN160P1C)	acciaio elettrolucidato, alluminio anodizzato
Rivestimento capote (CN160P1C)	tessuto Batik
Ruote (CN160P1W)	materiale plastico, poliuretano elastomerico, perno in acciaio inox elettrolucidato
Vassoio elemento di servizio (PCN60-PCN80-PCN110)	lamiera d'acciaio con verniciatura a polvere poliestere
Puntali	materiale termoplastico
Telo di copertura impermeabile	tessuto PES monospalmato su un lato PU
Rivestimento	tessuto in categorie limitate

### Product items/Prodotti

#### Recommended combinations/Abbinamenti suggeriti



2481255  
Lesia



2481207  
Lesia



0200W  
white polyethylene  
polietilene bianco



2369100  
Bali



2563287  
Agate



2593100  
Batik  
Batik



0200W  
white polyethylene  
polietilene bianco



2481255  
Lesia



2481101  
Lesia



0200W  
white polyethylene  
polietilene bianco



2481255  
Lesia



2481207  
Lesia



0200W  
white polyethylene  
polietilene bianco

#### Interlacing Intreccio



0200W  
white polyethylene  
polietilene bianco

#### Canopy cover (CNC160P1) Rivestimento capote



2593100  
white Batik fabric  
tessuto Batik bianco

#### Tray (PCN60 - PCN80 - PCN110) Vassoio

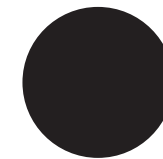

09005  
black painted  
verniciato nero

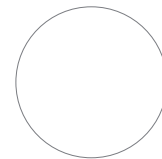

0179A  
white painted  
verniciato bianco



0179A  
white painted  
verniciato bianco



0200W  
white polyethylene  
polietilene bianco

## Canasta tables

Patricia Urquiola • 2007/2013

Inspiration • 264

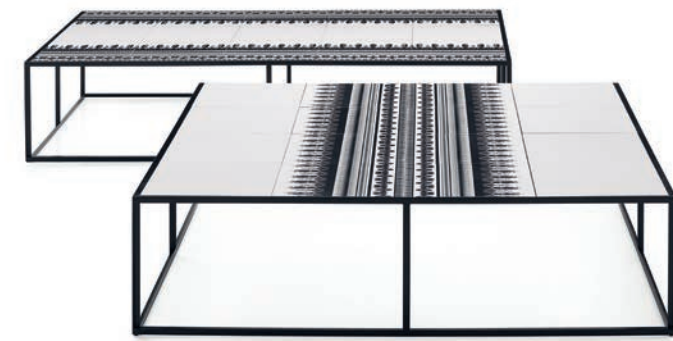
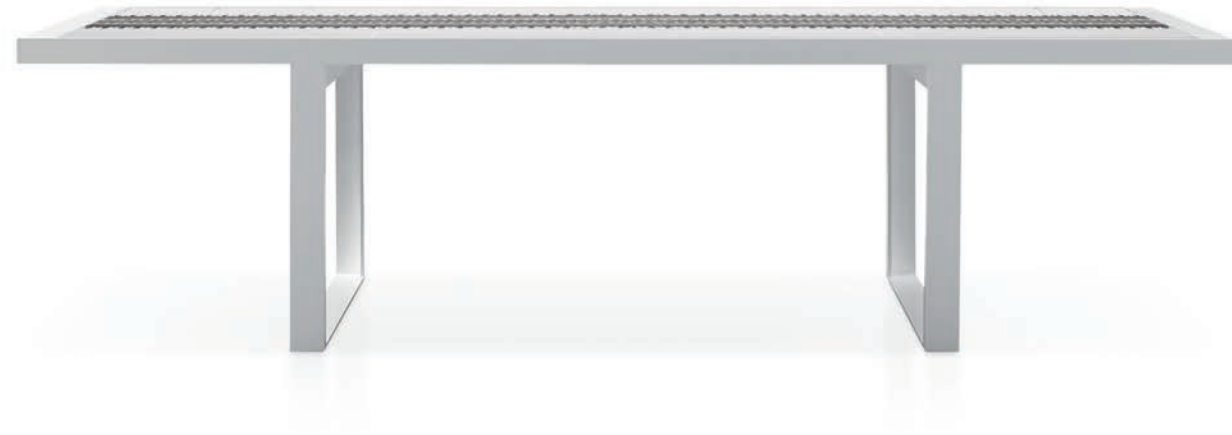

The Canasta collection includes tables and low tables in different sizes. The tables frames are in aluminium and the low tables frames are in steel. Both frames are painted with weather resistant polyester powder. The tops are covered with exclusive tiles with decorative patterns.

La collezione Canasta si completa di tavoli e tavoli bassi in diverse dimensioni. I tavoli hanno la struttura in alluminio mentre i tavoli bassi in acciaio. Entrambe le strutture sono verniciate a polvere poliestere resistente agli agenti atmosferici e piani rivestiti con piastrelle esclusive con motivi decorativi.



## Canasta tables

### Patricia Urquiola • 2007/2013

Inspiration • 264

#### Canasta tables

#### Canasta tavoli

TCN224

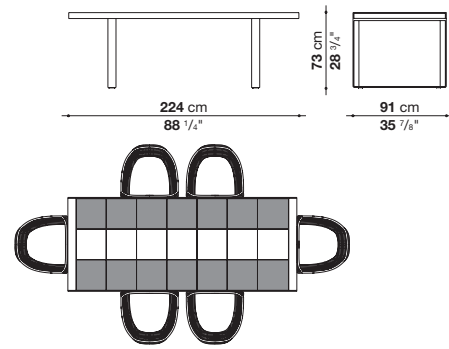

TCN283N

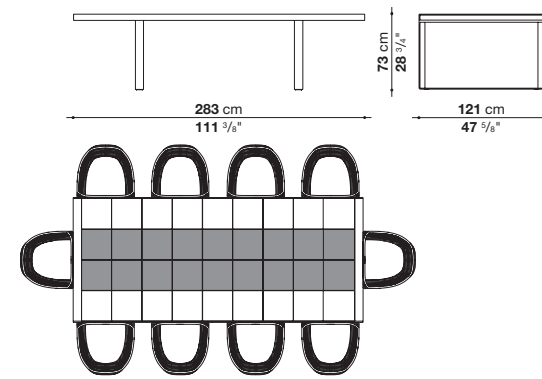

#### Low tables

#### Tavoli bassi

TCN12

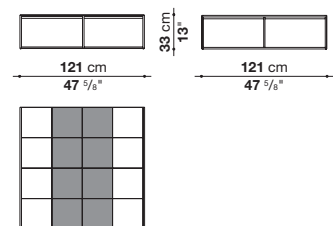

TCN15

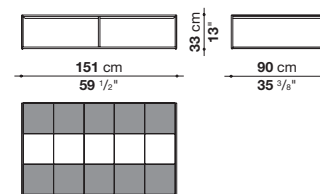

Frame	aluminium or steel with polyester powder painting	Struttura	alluminio o acciaio con verniciatura a polvere poliesteri
Top	tiles in porcelain stoneware	Piano	piastrelle in gres porcellanato
Ferrules	thermoplastic material	Puntali	materiale termoplastico
Waterproof cover cloth	PES fabric coated on one side in PU	Telo di copertura impermeabile	tessuto PES monospalmato su un lato PU

#### Top

#### Piano

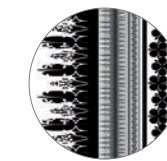

1510A  
porcelain stoneware with  
black / white decoration  
gres porcellanato con  
decoro nero / bianco

#### Frame (TCN224 - TCN283N)

#### Struttura

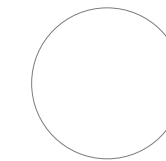

0179A  
white painted  
verniciato bianco

#### Frame (TCN12 - TCN15)

#### Struttura



09005  
black painted  
verniciato nero

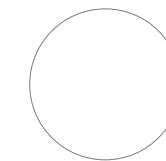

0179A  
white painted  
verniciato bianco

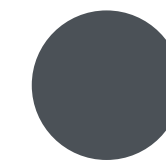

0236B  
anthracite painted  
verniciato antracite

The colours and materials shown are an indication. Images not in scale.  
La tonalità dei colori e dei materiali è indicativa. Immagini non in scala.

## Canasta '13

Patricia Urquiola • 2013

Inspiration • 268



Outdoor sofas, swivel sofas, high and low back armchairs for the garden from the Canasta '13 collection maintain the iconic design and the typologies of the entire Canasta series, but with a new look designed to blend in with the external environment even more. The colours of the woven material become more natural,

I divani da esterno, divani girevoli, poltrone alte e basse da esterno della collezione Canasta '13 mantengono il design iconico e le tipologie di tutta la serie Canasta e cambiano "veste" per fondersi maggiormente con l'ambiente esterno. I colori dell'intreccio si fanno più naturali tingendosi di un tortora mélange e la trama dell'intreccio

Tortora mélange, and the weave expands to let light and glimpses of the surroundings show through. Unique pieces, elegant outdoor furnishings that are super comfortable like the circular sofa with the swivel base, which lets you follow the sun and turn 360°.

si dispiega lasciando trasparire la luce e l'ambiente circostante. Pezzi unici, protagonisti eleganti dell'arredamento da esterno e super confortevoli come il divano circolare oversize con la base girevole per seguire il sole a 360°.

# Canasta '13

## Patricia Urquiola • 2013

Inspiration • 268

Sofas  
Divani

CNC190B

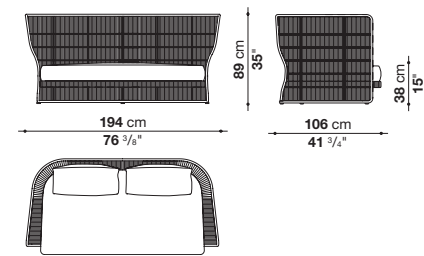

CNC226B

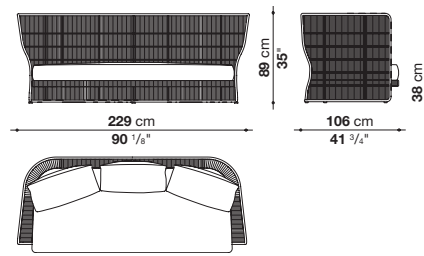

Armchairs  
Poltrone

CNC98PB

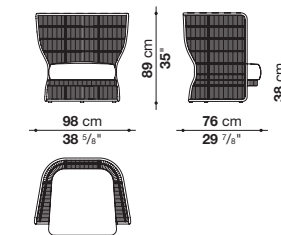

CNC98PA

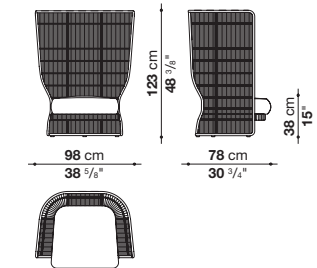

CNC160P1

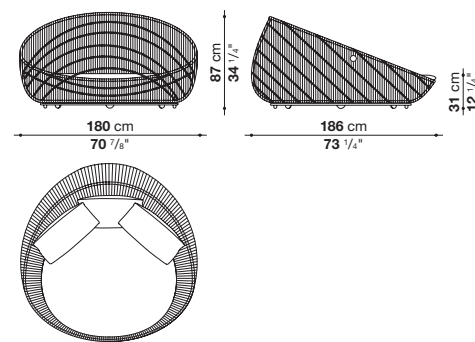

CNC160P1, CNC160P1C

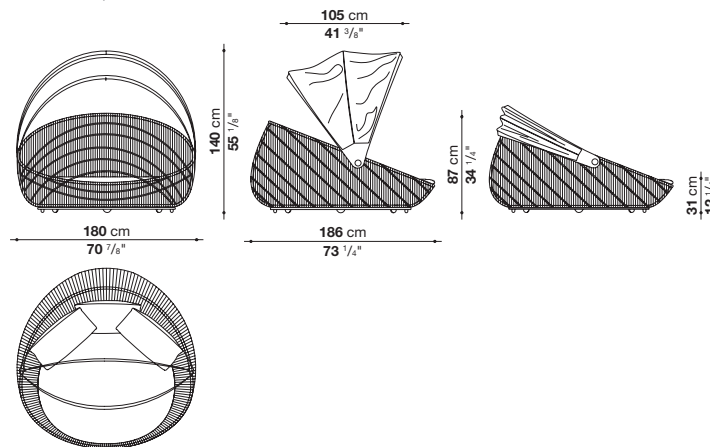

Chair  
Sedia

SCNC63

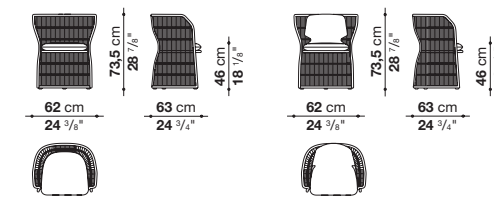

Service elements  
Elementi di servizio

PCNC60

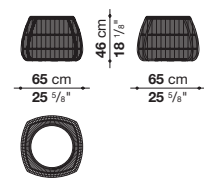

PCNC80

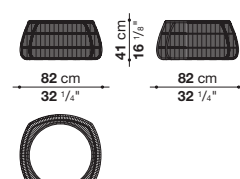

PCNC110

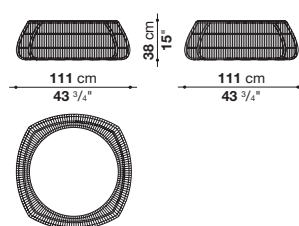

Small tables  
Tavolini

TCNC3

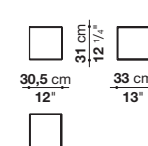

TCNC4

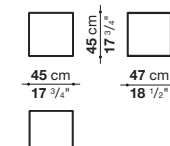

## Canasta '13

### Patricia Urquiola • 2013

Inspiration • 268

Frame	aluminium or steel with polyester powder painting
Interlacing	polyethylene fibre
Seat cushion (CNC190B-CNC226B-CNC98PB-CNC98PA)	shaped polyurethane, cover in water repellent polyester fibre (with heat-sealed ribbon)
Seat cushion (CNC160P1-SCNC63)	shaped polyurethane, cover in water repellent polyester fibre
Back cushion	polyester fibre, cover in water repellent polyester fibre
Canopy frame (CNC160P1C)	glass fibre
Canopy mechanism (CNC160P1C)	electro polished steel, anodized aluminium
Canopy cover (CNC160P1C)	Balivo fabric
Service element tray (PCNC60-PCNC80-PCNC110)	steel sheet with polyester powder painting
Wheels and ferrules	thermoplastic material
Cover	fabric in limited categories
Fame (TCNC3-TCNC4)	aluminium or steel with polyester powder painting
Top (TCNC3-TCNC4)	tiles in cement porcelain stoneware
Ferrules (TCNC3-TCNC4)	thermoplastic material
Waterproof cover cloth	PES fabric coated on one side in PU

Struttura	alluminio o acciaio con verniciatura a polvere poliestere
Intreccio	fibra di polietilene
Cuscino sedile (CNC190B-CNC226B-CNC98PB-CNC98PA)	poliuretano sagomato, fodera in fibra di di poliestere con trattamento idrorepellente (con cuciture termosaldate)
Cuscino sedile (CNC160P1-SCNC63)	poliuretano sagomato, fodera in fibra di poliestere con trattamento idrorepellente
Cuscino schienale	fibra di poliestere, fodera in fibra di poliestere con trattamento idrorepellente
Struttura capote (CNC160P1C)	vetroresina
Meccanismo capote (CNC160P1C)	acciaio elettrolucidato, alluminio anodizzato
Rivestimento capote (CNC160P1C)	tessuto Balivo
Vassoio elemento di servizio (PCNC60-PCNC80-PCNC110)	lamiera d'acciaio con verniciatura a polvere poliestere
Ruote e puntali	materiale termoplastico
Rivestimento	tessuto in categorie limitate
Struttura (TCNC3-TCNC4)	alluminio o acciaio con verniciatura a polvere poliestere
Piano (TCNC3-TCNC4)	piastrelle in gres porcellanato cemento
Puntali (TCNC3-TCNC4)	materiale termoplastico
Telo di copertura impermeabile	tessuto PES monospalmato su un lato PU

#### Interlacing

#### Intreccio

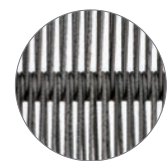

**0280P**  
tortora polyethylene  
polietilene tortora

#### Canopy cover (CNC160P1)

#### Rivestimento capote

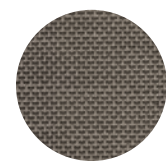

**2387280**  
tortora Balivo fabric  
tessuto Balivo tortora

#### Tray (PCNC60 - PCNC80 - PCNC110)

#### Vassoio

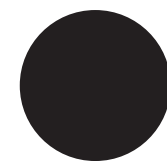

**09005**  
black painted  
verniciato nero

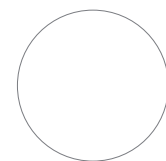

**0179A**  
white painted  
verniciato bianco

#### Top (TCNC3 - TCNC4)

#### Piano



**1560E**  
cement porcelain stoneware  
gres porcellanato cemento

#### Frame (TCNC3 - TCNC4)

#### Struttura

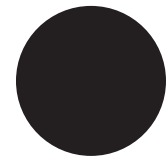

**09005**  
black painted  
verniciato nero

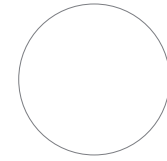

**0179A**  
white painted  
verniciato bianco

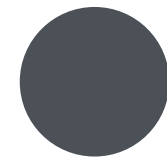

**0236B**  
anthracite painted  
verniciato antracite

#### Product items/Prodotti

#### Recommended combinations/Abbinamenti suggeriti



**2481255**  
Lesia



**2485255**  
Lipari



**0280P**  
tortora  
polyethylene  
polietilene  
tortora



**2481255**  
Lesia



**2481207**  
Lesia



**2485255**  
Lipari



**2387280**  
Balivo  
Balivo



**\* 0280P**  
tortora  
polyethylene  
polietilene  
tortora



**2481877**  
Lesia



**2481251**  
Lesia



**0280P**  
tortora  
polyethylene  
polietilene  
tortora



**0179A**  
white  
painted  
verniciato  
bianco



**2481877**  
Lesia



**2481251**  
Lesia



**0280P**  
tortora  
polyethylene  
polietilene  
tortora



**0280P**  
tortora  
polyethylene  
polietilene  
tortora



**0179A**  
white  
painted  
verniciato  
bianco



**0179A**  
white painted  
verniciato  
bianco



**09005**  
black painted  
verniciato nero



**1560E**  
cement porcelain  
stoneware  
gres porcellanato  
cemento

## Charles Outdoor

Antonio Citterio • 2010

Inspiration • 219



The Charles sofa system, a long-time bestseller for the company, is being introduced in an outdoor version: Charles Outdoor. Characteristics that made it a classic of pure contemporary taste have been left unchanged. The system will have the same slim frame, flexibility and signature design of the inverted “L” shape aluminium foot.

Il sistema di divani Charles, bestseller e longseller dell'azienda, viene proposto nella versione outdoor: Charles Outdoor. Rimangono inalterate le caratteristiche che lo hanno reso un classico dal gusto decisamente contemporaneo: la struttura sottile, la flessibilità del sistema e il design essenziale del piedino in alluminio a forma di “L” rovesciata.

Charles Outdoor  
Antonio Citterio • 2010  
Inspiration • 219



2571207  
Sirocco

2530280  
Lesia

2498102  
Leila

2481101  
Lesia

2485280  
Lipari



## Charles Outdoor

### Antonio Citterio • 2010

Inspiration • 219

Sofa  
Divano

CHO234

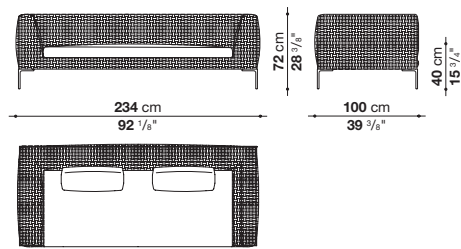

Terminal elements  
Elementi terminali

\* CHO160D

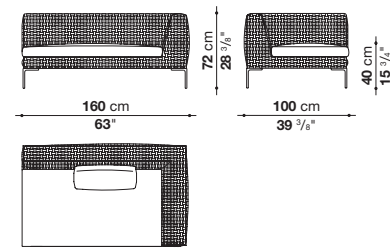

\* CHO234D

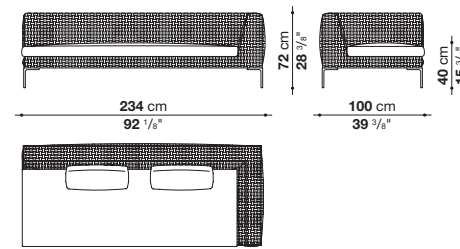

Chaise longue  
Chaise longue

\* CHO160LD

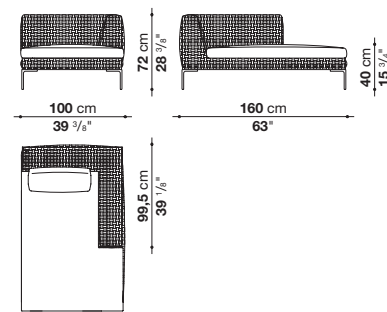

\* CHO234LD

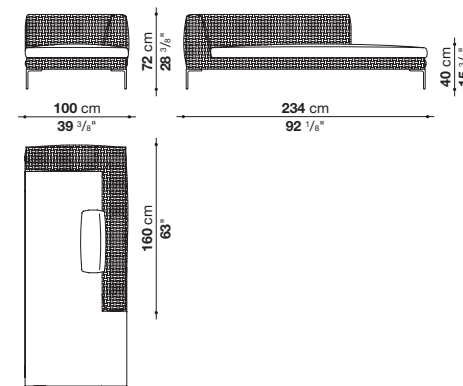

Armchair  
Poltrona

CHO84

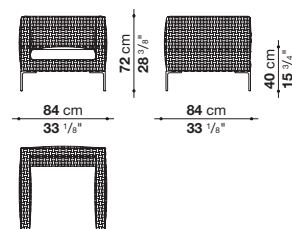

\* Elements available in right and left version. / Elementi disponibili nella versione destra e sinistra.  
The colours and materials shown are an indication. Images not in scale.  
La tonalità dei colori e dei materiali è indicativa. Immagini non in scala.

Internal frame	tubular aluminium and aluminium profiles
Interlacing	polypropylene fibre
Seat cushion	shaped polyurethane, cover in water repellent polyester fibre
Back cushion	polyester fibre, cover in water repellent polyester fibre
Feet	die-cast aluminium with polyester powder painting
Ferrules	thermoplastic material
Waterproof cover cloth	PES fabric coated on one side in PU
Cover	fabric in limited categories

Telaio interno	tubolari e profilati d'alluminio
Intreccio	fibra di polipropilene
Cuscino sedile	poliuretano sagomato, fodera in fibra di poliesteri con trattamento idrorepellente
Cuscino schienale	fibra di poliestere, fodera in fibra di poliestere con trattamento idrorepellente
Piedini	fusione d'alluminio con verniciatura a polvere poliestere
Puntali	materiale termoplastico
Telo di copertura impermeabile	tessuto PES monospalmato su un lato PU
Rivestimento	tessuto in categorie limitate

Interlacing  
Intreccio

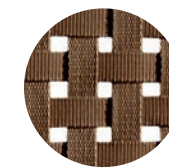

0115P  
brown polypropylene  
polipropilene marrone

Feet  
Piedini

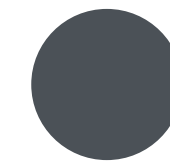

0174B  
bronzed nickel painted  
verniciato nickel bronzato

The colours and materials shown are an indication. Images not in scale.  
La tonalità dei colori e dei materiali è indicativa. Immagini non in scala.

## Colosseo Outdoor

### Naoto Fukasawa • 2020

Inspiration • 308



In 2020 Colosseo debuts outdoor in the new porcelain stoneware version in sauge and clay colors. A furnishing element with various functions depending on the occasion and need (coffee table and pouf). Colosseo takes its name from the designer's inspiration. Naoto Fukasawa has in fact arrived at the desired shape thinking of a solid in the shape of an upside-down truncated cone, creating an assonance with the structure of the famous Roman arena.

Nel 2020 Colosseo debutta nella nuova versione Outdoor, in gres porcellanato nei colori salvia e argilla. Elemento di arredo con varie funzioni a seconda delle occasioni e delle necessità (pouf e tavolino), Colosseo prende il nome dall'ispirazione del designer. Naoto Fukasawa è arrivato alla forma desiderata pensando ad un solido a forma di tronco di cono rovesciato alleggerito nella struttura da incavi a forma di arco, creando così una assonanza con la famosa arena romana.

Frame and top	stoneware	Struttura e piano	gres
Ferrules	plastic material	Puntali	materiale plastico

#### Service elements

Elementi di servizio

OCL40T

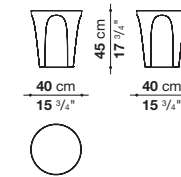

OCL45T

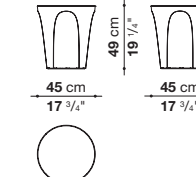

#### Top and frame

Piano e struttura

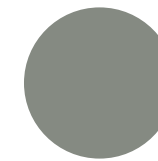

0416S  
sage stoneware  
gres salvia

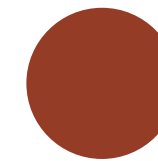

0302A  
clay stoneware  
gres argilla

The colours and materials shown are an indication. Images not in scale.  
La tonalità dei colori e dei materiali è indicativa. Immagini non in scala.



## Cordoba Outdoor

Foster+Partners, Industrial Design Studio • 2023

Inspiration • 37



The Cordoba armchair doubles its range with the introduction of its outdoor version. The shape remains the same as the indoor one, combining precise design, ergonomics, comfort and environmental responsibility, but the materials are all new.

In the new look, the frame in natural teak wood is combined with a polypropylene reinforced canvas cover, particularly suitable for the outdoor dimension. The touch is pleasantly rough and reminiscent of a natural fabric in every way.

La poltrona Cordoba raddoppia l'offerta con l'introduzione della sua versione outdoor. La forma rimane la medesima di quella indoor, unendo design preciso, ergonomia, comfort e responsabilità ambientale, ma i materiali sono tutti nuovi.

Nella nuova veste la struttura in legno di teak naturale si sposa con un rivestimento in tela armata di polipropilene, particolarmente idonea alla dimensione outdoor. Il tocco è piacevolmente ruvido e in tutto e per tutto analogo al tessuto naturale.

To emphasize the harmonic and relaxed image of the armchair, the covers are offered in colors inspired by nature: green, blue, brick and dove grey. To allow convenient maintenance of the structure, the coverings can be easily removed when needed. A choice that also represents the desire to move in the direction of an increasingly responsible design. All the components of Cordoba Outdoor, at the end of the life cycle of the product, can be in fact separated and disposed of following the path most suitable for each material.

Per sottolineare l'immagine armonica e rilassata della seduta, i rivestimenti sono proposti in colori ispirati alla natura: verde, blu, mattone e tortora. Per consentire una comoda manutenzione della struttura, i rivestimenti possono essere rimossi agevolmente quando necessario. Scelta che rappresenta anche la volontà di muoversi nella direzione di un design sempre più responsabile. Tutti i componenti di Cordoba Outdoor, al termine del ciclo di vita del prodotto, potranno infatti essere separati e smaltiti seguendo il percorso più adatto ad ogni materiale.

**Cordoba Outdoor**  
 Foster+Partners, Industrial Design Studio • 2023  
 Inspiration • 37



Frame	solid teakwood
Spacers	stainless steel
Ferrules	thermoplastic material
Waterproof cover cloth	PES fabric coated on one side in PU
Cover	fabric in limited categories

Struttura	legno massello di teak
Distanziali	acciaio inox
Puntali	materiale termoplastico
Telo di copertura impermeabile	tessuto PES monospalmato su un lato PU
Rivestimento	tessuto in categorie limitate

Armchair  
 Poltrona

OCR75

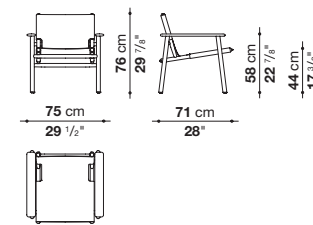

Frame  
 Struttura



0456T  
 natural teakwood  
 teak naturale

Seat and back  
 Seduta e schienale

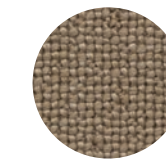

2572102  
 natural Laguna  
 Laguna naturale

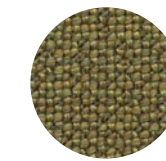

2822401  
 moss green Lamar  
 Lamar verde muschio

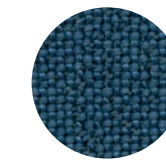

2822890  
 Sea blue Lamar  
 Lamar blu mare

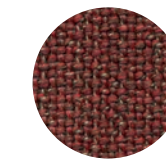

2822760  
 Lamar argilla  
 clay Lamar

The colours and materials shown are an indication. Images not in scale.  
 La tonalità dei colori e dei materiali è indicativa. Immagini non in scala.

**Cosmos Outdoor**  
 Jeffrey Bennett - 2019  
 Inspiration • 288



Frame	aluminium
Top	porcelain stoneware
Ferrules	thermopalstic material

Struttura	alluminio
Piano	gres porcellanato
Puntali	materiale plastico

Tables  
 Tavoli

OTC90R\_2

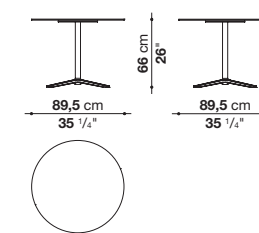

OTC90R\_1

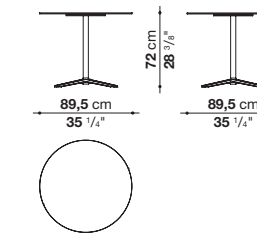

OTC90Q\_2

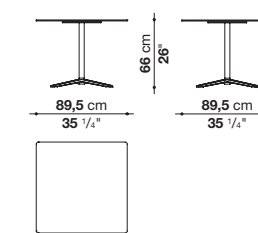

OTC90Q\_1

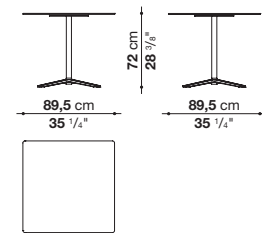

This collection includes harmonious tables which can be used in pairs or groups due to their compact size. They adapt easily to different environments both as contract furnishing schemes and residential balconies or terraces. These tables are entirely painted (sage, clay or anthracite) or with tops in porcelain stoneware (white or anthracite).

La collezione include una serie di tavoli dalle linee armoniose che possono essere utilizzati in coppia o in piccoli gruppi. La versatilità che li contraddistingue ne permette l'adattabilità a diversi contesti. Da progetti contract a balconi e terrazze ad uso residenziale. I tavoli possono essere interamente verniciati (salvia, argilla o antracite) oppure con il piano in gres porcellanato (bianco o antracite).

Frame  
 Struttura

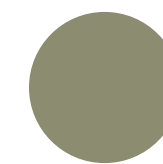

0427S  
 sage painted  
 verniciato salvia

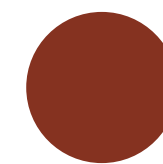

0750A  
 clay painted  
 verniciato argilla

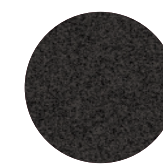

0236B  
 anthracite painted  
 verniciato antracite

Top  
 Piano

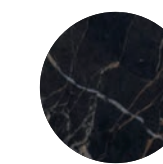

\* 0355N  
 anthracite stone  
 porcelain stoneware  
 gres porcellanato  
 pietra antracite

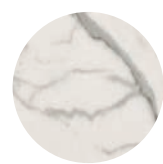

\* 0266B  
 white statuary  
 porcelain stoneware  
 gres porcellanato  
 statuario bianco

\* Image not in scale / Immagine non in scala

## Crinoline

Patricia Urquiola • 2008

Inspiration • 275



Can you picture the dresses that women wore in the 1800s?

Full, bell-shaped skirts held by crinolines (rigid underskirt garments) were spectacular “micro-architectures” commonly seen in living rooms everywhere.

All of the chairs in the Crinoline collection are designed to reflect this elegant look: the wide curve of the base is repeated in the seat and the curve of the backrest.

Avete presente le gonne delle dame ottocentesche? Gonfie, a campana, sostenute dalle crinoline (sottogonne rigide) erano scenografiche micro-architetture da salotto. “Più che romantica. Più che sensuale. L’ispirazione è esotica ed erotica”, dice Patricia Urquiola. Le poltrone e sedie Crinoline sono disegnate per rendere l’idea di questi abiti eleganti: l’ampia conca della base è ripresa nella seduta e nella curvatura dello schienale.

The Crinoline collection that in the years have become one of the most recognizable product of the B&B Italia Outdoor collection gets a new look and defines the new trendy color in the outdoor living: clay. With this new tone and the new outdoor proof polyethylene material for the interlacing will be easier to match it with all the other items to set amazing outdoor displays and scenarios.

La collezione Crinoline negli anni è diventata uno dei prodotti più riconoscibili della collezione B&B Italia Outdoor. Oggi si propone con un nuovo look che definisce in modo sicuro il colore attualmente più trendy nel mondo outdoor: il rosso argilla. Grazie alla nuova tonalità e al materiale polietilene outdoor-proof, sarà ancora più facile combinare Crinoline con tutti gli altri prodotti per realizzare layout e scenari outdoor d’effetto.

## Crinoline

Patricia Urquiola • 2008

Inspiration • 275



Armchairs, small armchairs, chairs and a stool are designed in several different shapes and heights. The polyethylene fibre interlacing are joined by natural or bronze abaca. Being a natural material, the product with abaca interlacing is suitable for indoors, covered outdoor spaces or verandas.

Sedie, uno sgabello, poltroncine e poltrone sono declinate in tipologie diverse per forma e altezza. Ad intrecci in fibra di polietilene, si affiancano quelli in abaca naturale o bronzo. Il prodotto con intreccio in abaca naturale, trattandosi di fibra naturale, è destinato all'utilizzo in ambienti interni, in esterni coperti o verande.

## Crinoline

### Patricia Urquiola • 2008

Inspiration • 275

#### Armchairs

Poltrone

C5P

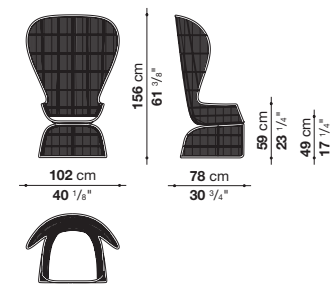

C5C - C5P\_FL

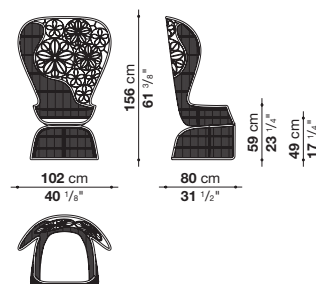

#### Small armchair

Poltroncina

C3P

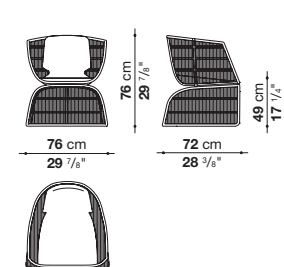

#### Chairs

Sedie

C1PF

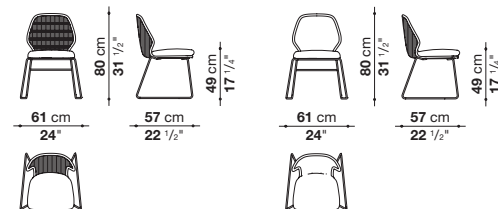

C2PF

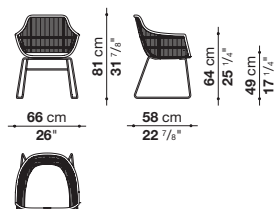

C2P

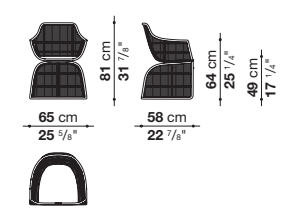

#### Stools

Sgabelli

C6PF

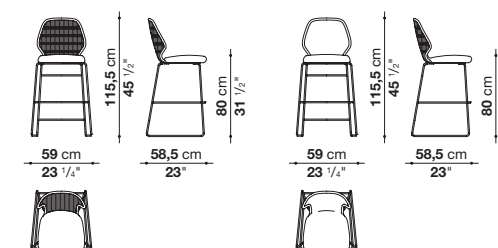

C7PF

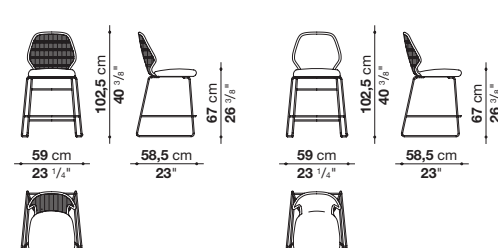

Base-frame	stainless steel or aluminium with polyester powder painting
Seat and back frame	aluminium with polyester powder painting
Seat cushion/Seat and back cushion	shaped polyurethane, cover in water repellent polyester fibre
Seat cushion (C5P-C5C-C5P_FL)	shaped polyurethane, cover in water repellent polyester fibre (with heat-sealed ribbon)
Interlacing	polyethylene fibre or abaca
Ferrules	thermoplastic material
Waterproof cover cloth	PES fabric coated on one side in PU
Cover	fabric in limited categories

Struttura base	alluminio con verniciatura a polvere poliesteri o acciaio inossidabile
Struttura sedile e schienale	alluminio con verniciatura a polvere poliesteri
Cuscino sedile/Cuscino sedile e schienale	poliuretano sagomato, fodera in fibra di poliesteri con trattamento idrorepellente
Cuscino sedile (C5P-C5C-C5P_FL)	poliuretano sagomato, fodera in fibra di poliesteri con trattamento idrorepellente (con cuciture termosaldate)
Intreccio	fibra di polietilene o abaca
Puntali	materiale termoplastico
Telo di copertura impermeabile	tessuto PES monospalmato su un lato PU
Rivestimento	tessuto in categorie limitate

Technical drawing of stool C6PF showing front, side, and top views with dimensions: 59 cm (23 1/4") width, 58,5 cm (23") seat width, 115,5 cm (45 1/2") height, 80 cm (31 1/2") seat height, and 23" seat depth.

Technical drawing of stool C7PF showing front, side, and top views with dimensions: 59 cm (23 1/4") width, 58,5 cm (23") seat width, 102,5 cm (40 3/8") height, 67 cm (26 3/8") seat height, and 23" seat depth.

#### Interlacing

Intreccio

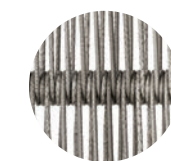

0280P  
tortora polyethylene  
polietilene tortora

#### Interlacing (C5C)

Intreccio



0360C  
grey abaca  
abaca grigio

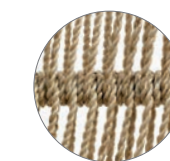

0203C  
natural abaca  
abaca naturale

#### Interlacing (C5P - C5P\_FL)

Intreccio

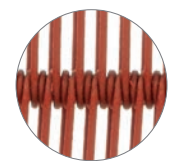

0773A  
clay polyethylene  
polietilene argilla

The colours and materials shown are an indication. Images not in scale.  
La tonalità dei colori e dei materiali è indicativa. Immagini non in scala.

## Erica

Antonio Citterio • 2017

Inspiration • 161



Sofas, armchair, small armchair and chair, including a stackable version, offer a technological blend of extruded and die-cast aluminium elements.

Their lightness and design makes them ideal for both public and residential settings, featuring seat and back cushions for ergonomic comfort together with strength for outdoor use.

The painted frames are available in two finish combinations: tortora painted aluminium frame with tortora colour polypropylene fibre interlacing or anthracite painted aluminium frame with anthracite colour polypropylene fibre interlacing.

Divani, poltrona, poltroncina e sedia, anche in versione impilabile, sono studiati con un mix tecnologico di estrusi e pressofusioni di alluminio. La loro leggerezza e il loro disegno ne suggeriscono l'utilizzo sia in spazi pubblici che residenziali, rispettando criteri di ergonomia e adattabilità ambientale. I cuscini sedile e schienale garantiscono un confortevole relax. Due le finiture delle strutture verniciate, abbinata ad intrecci di nastri in tessuto sintetico con un'anima interna ad alta tenacità studiata per l'utilizzo outdoor: struttura in alluminio verniciato tortora con intreccio in fibra di polipropilene tortora o struttura in alluminio verniciato antracite con intreccio in fibra di polipropilene antracite.

## Erica

Antonio Citterio • 2017

Inspiration • 161



H 45 cm



H 40 cm

H 67 cm



H 40 cm

The well-established identity of the Erica collection offers new dimensions for the chair, in line with the most current styles and trends. In addition to the version with traditional seat height, the chair is offered with a seat 5 cm lower. Perfect for private spaces, but also for hotels, it is suitable for relaxation and conviviality where it is designed to accompany low tables.

L'identità consolidata della collezione Erica propone nuove dimensioni per la sedia, in linea con gli stili e le tendenze più attuali. Oltre alla versione con altezza seduta tradizionale, la sedia è proposta con una seduta più bassa di 5 cm. Perfetta per gli spazi privati, ma anche per gli alberghi, si adatta al relax e alla convivialità laddove si preveda di abbinarla a tavoli bassi.



## Erica

### Antonio Citterio • 2017

Inspiration • 161

#### Sofas

##### Divani

E170

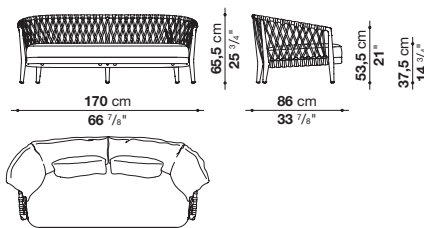

E216

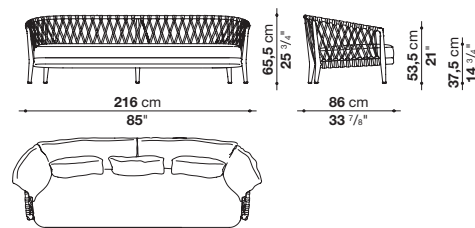

#### Small armchair

##### Poltroncina

E80P

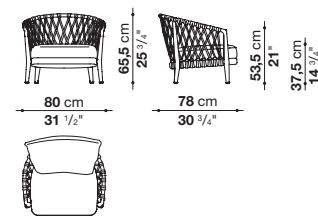

#### Armchair

##### Poltrona

E90P

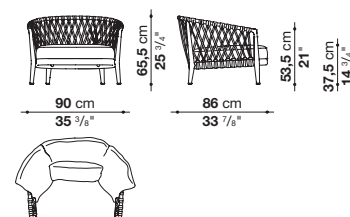

#### Chairs

##### Sedie

E61S

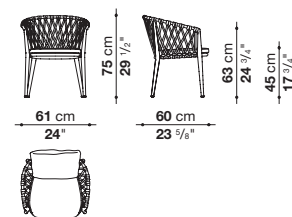

E61SB

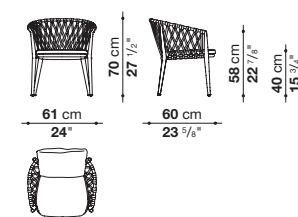

E61S\_1

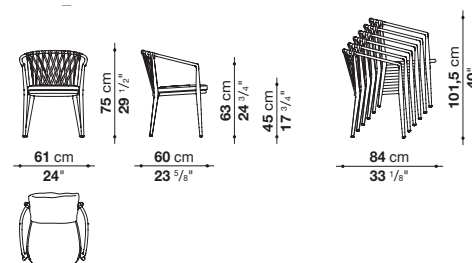

E61SB\_1

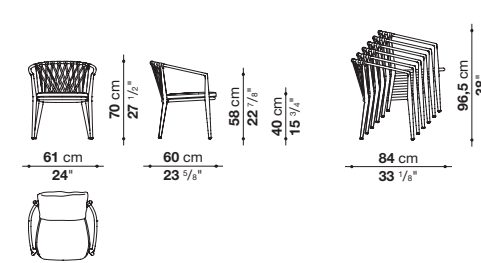

Frame	die-cast aluminium and extrusions with polyester powder painting	Struttura	pressofusione ed estrusi d'alluminio con verniciatura a polvere poliestere
Back upholstery (E170-E216-E90P-E80P)	shaped polyurethane of different density, Solutex fibre and visco-elastic polyurethane combination, cover in water repellent polyester fibre	Imbottitura schienale (E170-E216-E90P-E80P)	poliuretano sagomato a densità differenziata, combinazione fibra Solutex e poliuretano viscoelastico, fodera in fibra di poliestere con trattamento idrorepellente
Back upholstery (E61S-E61S_1 - E61SB - EG1SB_1)	polyester fibre and polyurethane combination	Imbottitura schienale (E61S-E61S_1 - E61SB - EG1SB_1)	combinazione fibra di poliestere e poliuretano
Seat upholstery	shaped polyurethane, Solutex fibre and visco-elastic polyurethane combination, cover in water repellent polyester fibre (with heat-sealed ribbon)	Imbottitura sedile	poliuretano sagomato, combinazione fibra Solutex e poliuretano viscoelastico, fodera in fibra di poliestere con trattamento idrorepellente (con cuciture termosaldate)
Interlacing	polypropylene fibre braid	Intreccio	treccia in fibra di polipropilene
Seat webbing	polypropylene fibre and synthetic rubber threads	Cinghiatura sedile	fibra di polipropilene e fili di gomma sintetica
Ferrules	thermoplastic material	Puntali	materiale termoplastico
Waterproof cover cloth	PES fabric coated on one side in PU	Telo di copertura impermeabile	tessuto PES monospalmato su un lato PU
Cover	fabric in limited categories	Rivestimento	tessuto in categorie limitate

#### Frame and interlacing matching

##### Abbinamento struttura e intreccio

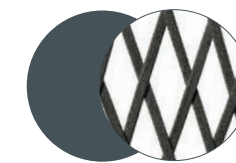

0828T

tortora painted / tortora polypropylene  
verniciato tortora / polipropilene tortora

0625G

anthracite painted / anthracite polypropylene  
verniciato antracite / polipropilene antracite

The colours and materials shown are an indication. Images not in scale.  
La tonalità dei colori e dei materiali è indicativa. Immagini non in scala.

Erica '19  
Antonio Citterio • 2019  
Inspiration • 161



Seat depth 96 cm



The Erica '19 sofas and armchair take up the formal lightness, the curved lines and the characteristic weaving of the Erica collection, but offer a lived-in look thanks to softer and more natural-looking cushions, a real invitation to relax.

I divani e la poltrona Erica '19 riprendono la leggerezza formale, le linee curve e il caratteristico intreccio della collezione Erica, ma offrono un aspetto vissuto grazie a cuscini dall'aspetto più morbido e naturale, vero e proprio invito al relax.

The sofas come in two sizes with a 96 cm or 76 cm seat depth and one with a 140 cm seat depth. The refined shades of the frame and interlacing are complemented by covers in an array of tones and designs, all co-ordinating with each other.

I divani sono proposti in due misure con seduta profonda 96 cm o 76 cm e una misura con seduta profonda 140 cm. Raffinate le tonalità delle strutture e degli intrecci, da abbinare a rivestimenti proposti in numerose nuance e fantasie tra loro coordinabili.

Erica '19  
Antonio Citterio • 2019  
Inspiration • 161



Seat depth 76 cm



Last born of the family, a sofa with 76 cm seat depth. Ideal for relaxing, but also to be combined with dining tables for convivial moment.

Ultimo nato della famiglia, un divano dalla seduta profonda 76 cm. Ideale per rilassarsi, ma anche per essere accostato ai tavoli da pranzo per momenti conviviali.

## Erica '19

Antonio Citterio • 2019

Inspiration • 161



The 140 cm deep sofa is particularly welcoming, allowing for a semi-reclined and informal seat for real relaxing moments in the open air. It is equipped with a series of soft cushions for extra comfort.

Particolarmente accogliente il divano profondo 140 cm che consente una seduta semisdraiata e informale per veri e propri momenti relax all'aria aperta. E' corredato da una serie di morbidi cuscini per un extra comfort.

The Erica '19 chair, also available in stackable version, has a polyester powder painted aluminium frame and a backrest characterised by an exclusive interlacing. Refined colour combinations include a single-color anthracite or dove grey for the frame and interlacing, or a sage frame with a natural colored interlacing. The seat cushion comes in a wide range of fabric covers.

La sedia Erica '19, anche in versione impilabile, ha la struttura in alluminio verniciato a polvere poliestere e lo schienale caratterizzato da un esclusivo intreccio. Raffinati gli accostamenti cromatici che prevedono struttura e intreccio monocolore antracite o in tortora, oppure struttura salvia con intreccio naturale.

Erica '19  
Antonio Citterio • 2019  
Inspiration • 161

Sofas  
Divani

9NE170

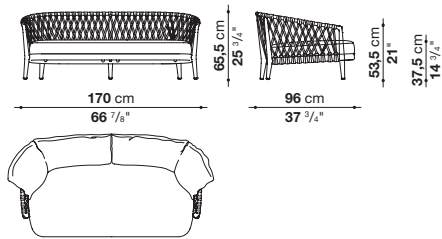

7NE170

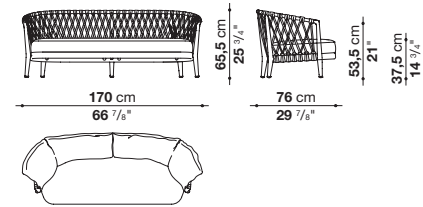

9NE216

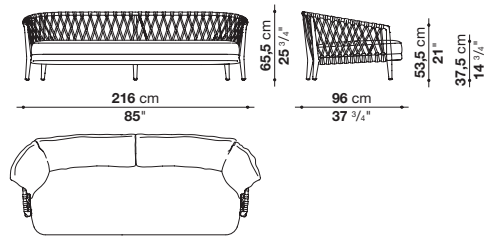

7NE216

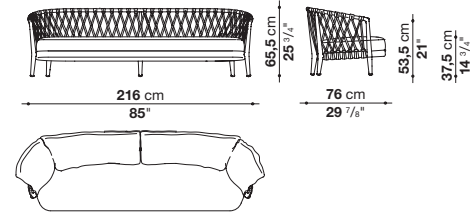

NE153

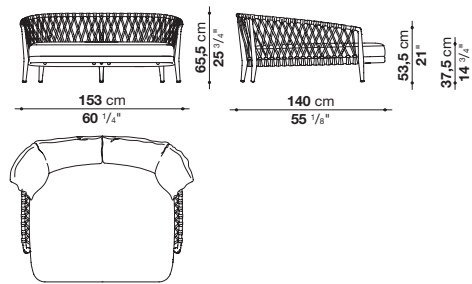

Small armchair  
Poltroncina

NE80P

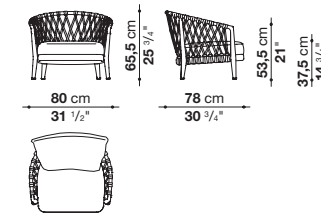

Chair  
Sedia

NE61S\_I

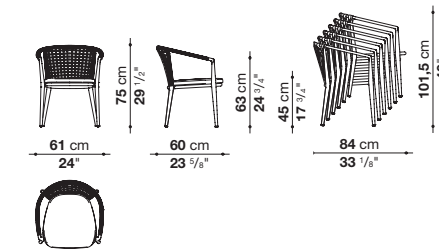

## Erica '19

### Antonio Citterio • 2019

Inspiration • 161

Frame	die-cast aluminium and extrusions with polyester powder painting
Back upholstery	recycled polyester fibre from PET, cover in water repellent polyester fibre
Back upholstery (British Standard version)	shaped polyurethane of different density, Solutex fibre and visco-elastic polyurethane combination, cover in water repellent polyester fibre
Back upholstery (NE61S_I) (British Standard version)	polyester fibre and polyurethane combination
Seat upholstery	shaped polyurethane, recycled polyester fibre from PET, cover in water repellent polyester fibre
Seat upholstery (British Standard version)	shaped polyurethane, Solutex fibre and visco-elastic polyurethane combination, cover in water repellent polyester fibre (with heat-sealed ribbon)
Seat webbing	polypropylene fibre and synthetic rubber threads
Interlacing	polypropylene fibre braid
Ferrules	thermoplastic material
Waterproof cover cloth	PES fabric coated on one side in PU
Cover	fabric in limited categories (with profile)
Cover (British Standard version)	fabric in limited categories (without profile)

Struttura	pressofusione ed estrusi d'alluminio con verniciatura a polvere poliestere
Imbottitura schienale	fibra di poliestere riciclata da PET, fodera in fibra di poliestere con trattamento idrorepellente
Imbottitura schienale (versione British Standard)	poliuretano sagomato a densità differenziata, combinazione fibra Solutex e poliuretano viscoelastico, fodera in fibra di poliestere con trattamento idrorepellente
Imbottitura schienale (NE61S_I) (versione British Standard)	combinazione fibra di poliestere e poliuretano
Imbottitura sedile	poliuretano sagomato, ecogreen (misto polietilene e poliestere), fodera in fibra di poliestere con trattamento idrorepellente
Imbottitura sedile (versione British Standard)	poliuretano sagomato, combinazione fibra Solutex e poliuretano viscoelastico, fodera in fibra di poliestere con trattamento idrorepellente (con cuciture termosaldate)
Cinghiatura sedile	fibra di polipropilene e fili di gomma sintetica
Intreccio	treccia in fibra di polipropilene
Puntali	materiale termoplastico
Telo di copertura impermeabile	tessuto PES monospalmato su un lato PU
Rivestimento	tessuto in categorie limitate (con profilo)
Rivestimento (versione British Standard)	tessuto in categorie limitate (senza profilo)

#### Frame and interlacing matching (NE61S\_I)

Abbinamento struttura e intreccio

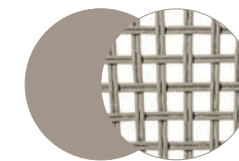

0813T

tortora painted / tortora polypropylene  
verniciato tortora / polipropilene naturale

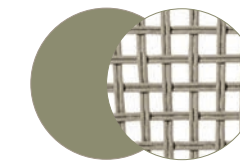

0742S

sage painted / natural polypropylene  
verniciato salvia / polipropilene naturale

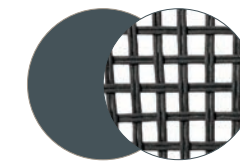

0688A

anthracite painted / anthracite polypropylene  
verniciato antracite / polipropilene antracite

#### Frame and interlacing matching

Abbinamento struttura e intreccio



0828T

tortora painted / tortora polypropylene  
verniciato tortora / polipropilene naturale



0702N

sage painted / natural polypropylene  
verniciato salvia / polipropilene naturale



0625G

anthracite painted / anthracite polypropylene  
verniciato antracite / polipropilene antracite

#### Seat and back cushion profile

Profilo cuscino sedile e schienale

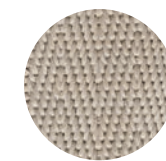

0041E

cream white  
bianco panna

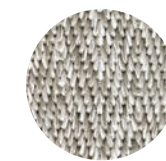

0082N

natural  
naturale

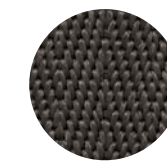

0054G

dark grey  
grigio scuro

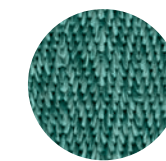

00585A

acquamarine  
acquamarina

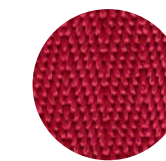

0075R

red  
rosso

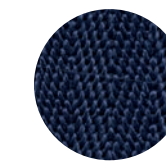

0095B

blue  
blu

The colours and materials shown are an indication. Images not in scale.  
La tonalità dei colori e dei materiali è indicativa. Immagini non in scala.

Erica '19  
Antonio Citterio • 2019  
Inspiration • 161

2568715  
Salinas

2569400  
Ermitage

2569101  
Ermitage





2568735  
Salinas

2569840  
Ermitage





Product items/Prodotti  
Recommended combinations/Abbinamenti suggeriti







-   
2569775  
Ermitage
-   
2568715  
Salinas
-   
2568735  
Salinas
-   
0082N  
natural profile  
profilo naturale







-   
2568715  
Salinas
-   
0082N  
natural profile  
profilo naturale
-   
0625G  
anthracite painted  
anthracite polypropylene  
verniciato antracite  
polipropilene antracite







-   
2569400  
Ermitage
-   
2568715  
Salinas
-   
2568735  
Salinas
-   
0082N  
natural profile  
profilo naturale

-   
0702N  
sage painted  
natural polypropylene  
verniciato salvia  
polipropilene naturale



-   
2569840  
Ermitage
-   
2568715  
Salinas
-   
2568735  
Salinas
-   
0095B  
blue profile  
profilo blu



-   
2569400  
Ermitage
-   
2498207  
Leila
-   
0082N  
natural profile  
profilo naturale
-   
0742S  
sage painted  
natural polypropylene  
verniciato salvia  
polipropilene naturale

## Fat-Fat Outdoor

### Patricia Urquiola • 2019

Inspiration • 310



The concept of a tray helped create four small outdoor tables with steel frames that give them a lightweight look. These small tables are entirely painted or with tops in porcelain stoneware.

Il tema del vassoio viene ripreso per dar vita a quattro tavolini per esterni il cui aspetto leggero è merito della struttura in acciaio. I tavolini sono proposti interamente verniciati oppure con piano in gres porcellanato.

Frame	steel profile
Top	porcelain stoneware or steel sheet
Tray	steel sheet
Ferrules	thermoplastic material

Struttura	profilati d'acciaio
Piano	gres porcellanato o lamiera d'acciaio
Vassoio	lamiera d'acciaio
Puntali	materiale termoplastico

#### Small tables

##### Tavoli

OTF42

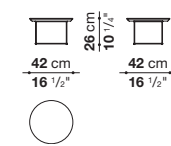

OTF62

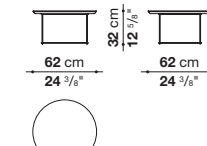

OTF62A

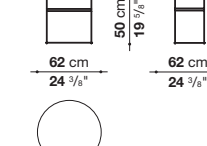

OTF92

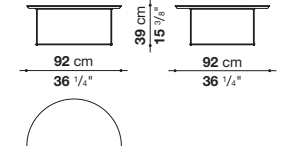

OTF42G

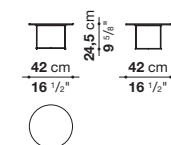

OTF62G

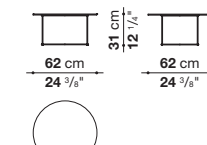

OTF62AG

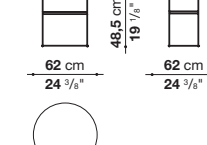

OTF92G

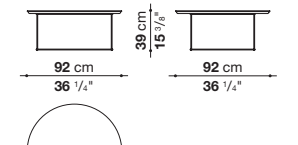

#### Trays

##### Vassoi

OF42V

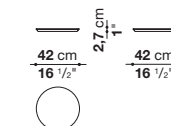

OF62V

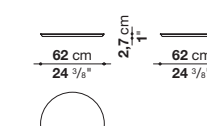

OF92V

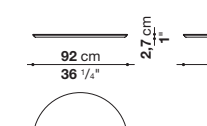

#### Frame and top

##### Struttura e piano

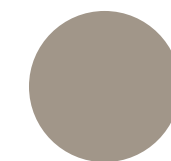

0380T  
tortora painted  
verniciato tortora

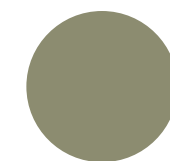

0427S  
sage painted  
verniciato salvia

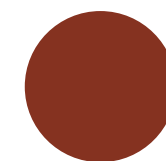

0750A  
clay painted  
verniciato argilla

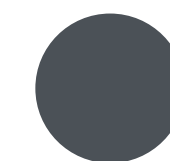

0236B  
anthracite painted  
verniciato antracite

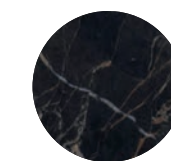

0355N  
anthracite stone  
porcelain stoneware  
gres porcellanato  
pietra antracite

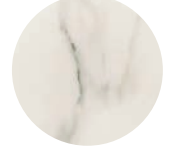

0266B  
white stone  
porcelain stoneware  
gres porcellanato  
bianco

#### Top (OTF42G-OTF62G-OTF62AG-OTF92G)

##### Piano

The colours and materials shown are an indication. Images not in scale.  
La tonalità dei colori e dei materiali è indicativa. Immagini non in scala.



## Fat-Sofa Outdoor

Patricia Urquiola • 2015

Inspiration • 253



The rounded, soft and sinuous shapes of the Fat-Sofa seating system are the base for the outdoor version, characterized by a brand new interlacing design. Its fully padded seat is accompanied by a metal frame backrest that supports the original weave, creating a special play of fullness and emptiness. The large weave pattern, made of tortora coloured twisted polyethylene fibres, makes

Le forme arrotondate, morbide e sinuose, del sistema di sedute Fat-Sofa vengono riprese nella versione da esterni, caratterizzata da un'inedita proposta di intreccio. La seduta completamente imbottita è accompagnata ad uno schienale con struttura in metallo su cui si tesse l'originale intreccio, creando uno speciale gioco di pieni e vuoti. L'intreccio, di effetto grafico e dimensioni macro, realizzato con fibre

the design unique, respecting the designer's idea of lightness, transparency and puts the furnishings in an open "dialogue" with the surrounding environment. Fat-Sofa Outdoor consists of six types, ranging from the linear sofa to a large relax island, from two height variants of the armchair to a range of different sizes of ottomans.

di polietilene ritorte di color tortora, conferisce unicità al progetto, nel rispetto dell'idea della designer di leggerezza, trasparenza e "dialogo" dell'elemento di arredo con l'ambiente circostante. Fat-Sofa Outdoor si compone di sei tipologie, che spaziano dal divano lineare ad un'isola relax di ampie dimensioni, dalla poltrona con schienale in due altezze ad una serie di elementi pouf di diverse dimensioni.

## Fat-Sofa Outdoor

### Patricia Urquiola • 2015

Inspiration • 253

#### Sofas

Divani

FA150

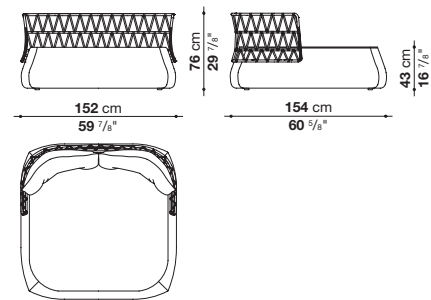

FA230

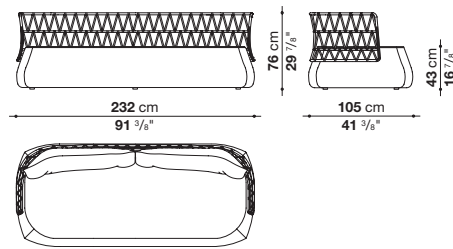

#### Armchairs

Poltrone

FA91B

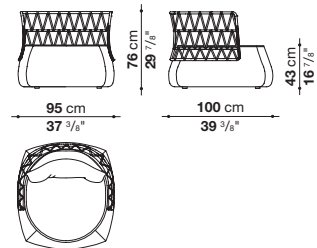

FA91A

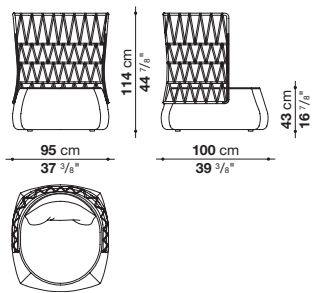

#### Ottomans

Pouf

FA61P

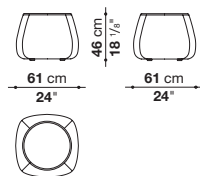

FA76P

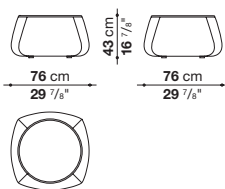

Frame	aluminium with polyester powder painting
Interlacing	polyethylene fibre
Internal frame	tubular steel and steel profiles, polystyrene foam
Internal frame upholstery	Bayfit® (Bayer®) flexible cold shaped polyurethane foam, shaped polyurethane of different density, water repellent polyester fibre cover (with heat-sealed ribbon)
Internal frame (FA61P-FA76P)	polystyrene foam, MDF wood fibre panel with Umidax® high humidity resistance
Internal frame upholstery (FA61P-FA76P)	Bayfit® (Bayer®) flexible cold shaped polyurethane foam, shaped polyurethane, water repellent polyester fibre cover (with heat-sealed ribbon)
Back cushion	polyester fibre, cover in water repellent polyester fibre
Bottom base	100% polyamide fabric coated PVC, PVC trimming
Feet	thermoplastic material
Waterproof cover cloth	PES fabric coated on one side in PU
Cover	fabric in limited categories

Struttura	alluminio con verniciatura a polvere poliesteri
Intreccio	fibra di polietilene
Telaio interno	tubolari e profilati d'acciaio, polistirolo espanso
Imbottitura telaio interno	schiuma di poliuretano flessibile a freddo Bayfit® (Bayer®), poliuretano sagomato a densità differenziata, fodera in fibra di poliesteri con trattamento idrorepellente (con cuciture termosaldate)
Telaio interno (FA61P-FA76P)	polistirolo espanso, pannello in fibra di legno MDF ad alta resistenza all'umidità Umidax®
Imbottitura telaio interno (FA61P-FA76P)	schiuma di poliuretano flessibile a freddo Bayfit® (Bayer®), poliuretano sagomato, fodera in fibra di poliesteri con trattamento idrorepellente (con cuciture termosaldate)
Cuscino schienale	fibra di poliesteri, fodera in fibra di poliesteri con trattamento idrorepellente
Fondo	tessuto 100% poliammide spalmato PVC, guarnizione in PVC
Piedini	materiale termoplastico
Telo di copertura impermeabile	tessuto PES monospalmato su un lato PU
Rivestimento	tessuto in categorie limitate

#### Interlacing

Intreccio



0612T

tortora polyethylene  
polietilene tortora

The colour and material shown are an indication. Image not in scale.  
La tonalità del colore e del materiale è indicativa. Immagine non in scala.

## Flair O' Outdoor

Monica Armani • 2023

Inspiration • 55



The Flair O' chair is enriched with a surprising outdoor version. Geometrically similar to the indoor one, it is characterized by a sturdy, lightweight aluminum frame completely covered with an interlacing of polypropylene ribbons, following a meticulous hand-crafted process. In particular, the backrest is woven on a special circular loom (tombolo) in line with an ancient technique typical of the area where the B&B Italia headquarter is located. Two padded cushions complete the chair, defining its shape and providing even more comfort.

La sedia Flair O' si arricchisce di una sorprendente versione outdoor. Geometricamente affine a quella indoor, è caratterizzata da un telaio leggero in alluminio completamente ricoperto da un intreccio di nastri in polipropilene seguendo un processo artigianale meticoloso. In particolare, l'intreccio dello schienale è realizzato utilizzando un telaio circolare (tombolo) secondo un'antica tecnica tipica della zona in cui si trova la sede di B&B Italia. Due cuscini imbottiti completano la sedia, definendo la forma e regalando ancora più comfort.

## Flair O' Outdoor

### Monica Armani • 2023

Inspiration • 55



Flair O' Outdoor is proposed in two heights to match with the two heights of the Allure O' Outdoor tables. In addition to the classic seating height of 47 cm, a new less imposing height of 42 cm has been introduced, less stiff and more devoted to relaxation. Both versions can be covered with interlacing in night blue, clay and dove grey colors, to be matched in harmony or in contrast to the Allure O' Outdoor tables.

Flair O' Outdoor è proposta in due altezze da abbinare alle due altezze tavoli Allure O' Outdoor. Oltre alla classica altezza di seduta di 47 cm, arriva una nuova altezza di 42 cm, meno impettita e più votata al relax. Entrambe le versioni possono essere rivestite con intreccio nei colori blu notte, argilla e tortora, da abbinare in sintonia o in contrasto ai tavoli Allure O' Outdoor.

Frame	tubular aluminium	Struttura	tubolari d'alluminio
Interlacing	polypropylene fibre braid	Intreccio	treccia in fibre di polipropilene
Back upholstery	recycled polyester fibre from PET, cover in water repellent polyester fibre	Imbottitura schienale	fibra di poliestere riciclata da PET, fodera in fibra di poliestere con trattamento idrorepellente
Seat upholstery	flexible polyurethane foam, cover in water repellent polyester fibre	Imbottitura sedile	poliuretano espanso flessibile, fodera in fibra di poliestere con trattamento idrorepellente
Ferrules	thermoplastic material	Ferrules	materiale termoplastico
Waterproof cover cloth	PES fabric coated on one side in PU	Telo di copertura impermeabile	tessuto PES monospalmato su un lato PU
Cover	fabric in limited categories	Rivestimento	tessuto in categorie limitate

#### Sedie Chairs

OFL60\_A

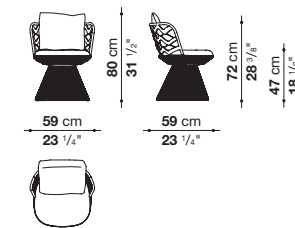

OFL60\_B

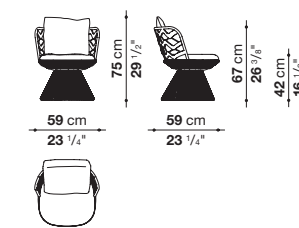

#### Interlacing Intreccio

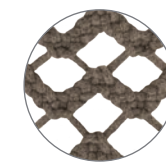

0061T  
dove grey polypropylene  
polipropilene tortora

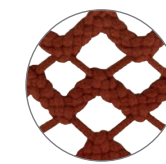

0087A  
clay polypropylene  
polipropilene argilla

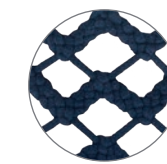

0049B  
night blue polypropylene  
polipropilene blu notte

The colours and materials shown are an indication. Images not in scale.  
La tonalità dei colori e dei materiali è indicativa. Immagini non in scala.

## Frank Outdoor

### Antonio Citterio • 2019

Inspiration • 322



This outdoor ottomans have contrasting profiles matched to colourful outdoor fabrics to provide a touch of colour to your outdoor furnishings.

Pouf per esterni che si caratterizzano per l'abbinamento di profili a contrasto abbinati a colorati tessuti outdoor e che donano una nota di vitale agli arredi per esterno.

Internal frame	tubular steel and steel profiles
Upholstery	Bayfit® flexible cold shaped polyurethane foam, water repellent polyester fibre cover (with heat-sealed ribbon)
Ferrules	thermoplastic material
Waterproof cover cloth	PES fabric coated on one side in PU
Cover	fabric in limited categories (with profile)

Telaio interno	tubolari e profilati d'acciaio
Imbottitura	schiuma di poliuretano flessibile a freddo Bayfit®, fodera in fibra di poliestere con trattamento idrorepellente (con cuciture termosaldate)
Puntali	materiale termoplastico
Telo di copertura impermeabile	tessuto PES monospalmato su un lato PU
Rivestimento	tessuto in categorie limitate (con profilo)

#### Ottoman

##### Pouf

OF58P

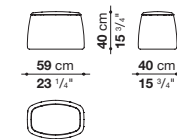

#### Profile

##### Profilo

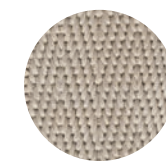

0041E  
cream white  
bianco panna

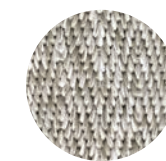

0082N  
natural  
naturale

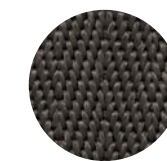

0054G  
dark grey  
grigio scuro

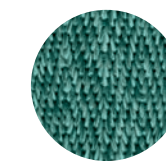

00585A  
acquamarine  
acquamarina

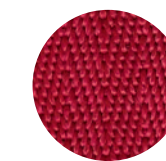

0075R  
red  
rosso

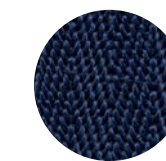

0095B  
blue  
blu

The colours and materials shown are an indication. Images not in scale.  
La tonalità dei colori e dei materiali è indicativa. Immagini non in scala.

## Ginepro

Antonio Citterio • 2020  
Inspiration • 225



The Ginepro table is made with an anthracite painted aluminum structure and a Serpentine stone top extremely durable and precious as the linear and timeless style.

Il tavolo Ginepro è realizzato con struttura in alluminio verniciato antracite e piano in pietra Serpentino estremamente durevole e pregiata in linea con lo stile lineare e senza tempo.

With its two shapes (round and rectangular with rounded corners) and four dimensions, it lends itself to be placed in different outdoor environments: terraces, verandas, patios and gardens.

Con le sue due forme (rotondo e rettangolare con angoli smussati) e quattro dimensioni, si presta ad essere collocato in ambienti differenti: terrazze, verande, patio e giardini.

# Ginepro

## Antonio Citterio • 2020

Inspiration • 225

Tables  
Tavoli

TGS105R

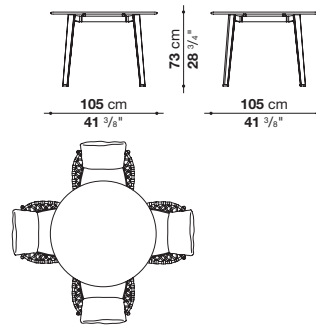

TGS140R

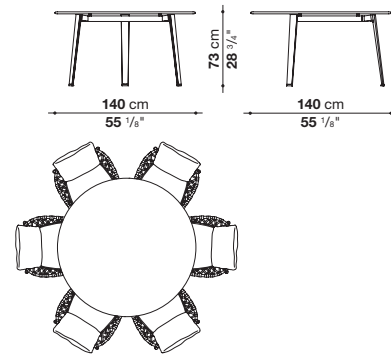

TGS190

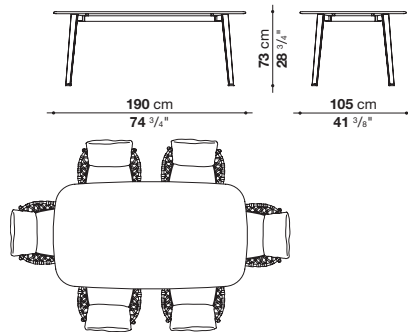

TGS250

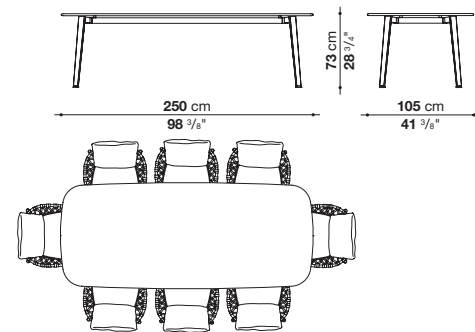

Top	Serpentine stone	Piano	pietra Serpentino
Frame	die-cast aluminium and extrusions with polyurethane painting	Struttura	fusione ed estrusi d'alluminio con verniciatura poliuretanica
Ferrules	thermoplastic material	Puntali	materiale termoplastico
Waterproof cover cloth	PES fabric coated on one side in PU	Telo di copertura impermeabile	tessuto PES monospalmato su un lato PU

Top  
Piano

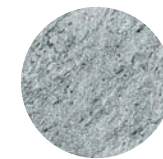

040SS  
Serpentine stone  
pietra Serpentino

Frame  
Struttura

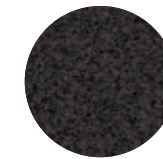

0236B  
anthracite painted  
verniciato antracite

The colours and materials shown are an indication. Images not in scale.  
La tonalità dei colori e dei materiali è indicativa. Immagini non in scala.

## Ginestra

Antonio Citterio • 2017

Inspiration • 239



Collection of large rectangular and round dining tables featuring natural teakwood structural details and designed tops, studied to match central inserts made of Calacatta white porcelain stoneware. The same collection features a chair, always in natural teakwood, with sinuous harmonious lines that are clearly inspired by northern trends. It is characterised by an interlacing in polypropylene fibre that is ideal for outdoor use. Colours are chosen to match natural teakwood with a beige interlacing. Comfort is guaranteed by seat and back cushions.

Collezione di tavoli da pranzo rettangolari e rotondi di grandi dimensioni caratterizzati da dettagli strutturali e disegni dei top realizzati in teak naturale che si abbinano ad inserti centrali realizzati in gres porcellanato bianco Calacatta. Della stessa serie una sedia, sempre in teak naturale, dalle linee sinuose e fluide di chiara ispirazione nordica, caratterizzata da un intreccio di nastri in tessuto sintetico adatto all'utilizzo outdoor. Lo studio cromatico ha previsto l'abbinamento del teak naturale ad un intreccio con nastro di colore beige. Il comfort è garantito da un cuscino sedile e schienale.



## Ginestra

### Antonio Citterio • 2017

Inspiration • 239

#### Tables

Tavoli

GN220T

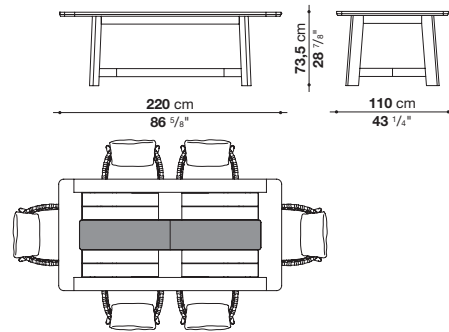

GN280T

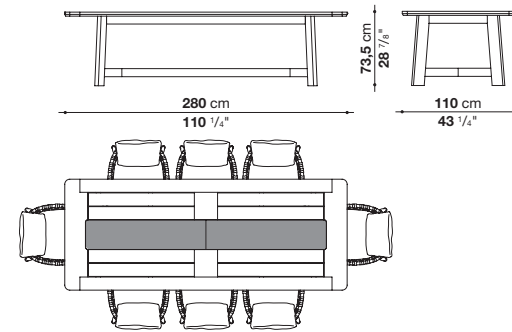

GN180TR

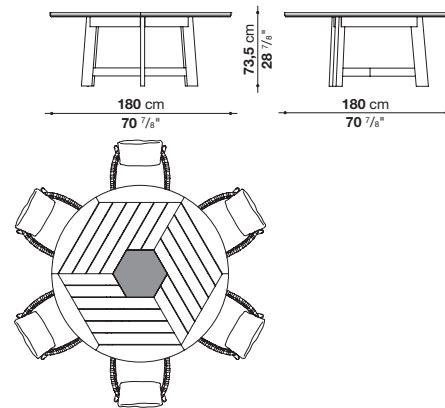

#### Chair

Sedia

GN60

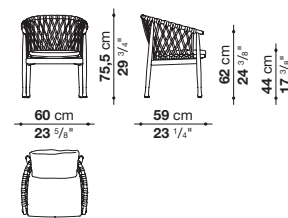

Frame and top (GN280T-GN220T-GN180TR)	solid wood
Back upholstery	polyester fibre and polyurethane combination
Seat upholstery	shaped polyurethane, Solutex fibre and visco-elastic polyurethane combination, cover in water repellent polyester fibre
Interlacing	polypropylene fibre braid
Top section	porcelain stoneware
Ferrules	thermoplastic material
Waterproof cover cloth	PES fabric coated on one side in PU
Cover	fabric in limited categories

Struttura e piano (GN280T-GN220T-GN180TR)	legno massello
Imbottitura schienale	combinazione fibra di poliestere e poliuretano
Imbottitura sedile	poliuretano sagomato, combinazione fibra Solutex e poliuretano viscoelastico, fodera in fibra di poliestere con trattamento idrorepellente
Intreccio	treccia in fibra di polipropilene
Inserto piano	gres porcellanato
Puntali	materiale termoplastico
Telo di copertura impermeabile	tessuto PES monospalmato su un lato PU
Rivestimento	tessuto in categorie limitate

#### Tables frame and top

Struttura e piano tavoli



0456T  
natural teakwood  
teak naturale

#### Table top section

Inserto piano tavolo



0301B  
Calacatta white porcelain stoneware  
gres porcellanato bianco Calacatta

#### Interlacing (GN60)

Intreccio



0312B  
beige polypropylene  
polipropilene beige

The colours and materials shown are an indication. Images not in scale.  
La tonalità dei colori e dei materiali è indicativa. Immagini non in scala.

## Gio

Antonio Citterio • 2016

Inspiration • 209



Gio, designed by Antonio Citterio, is the series with a contemporary classic accent dedicated to living in the open air. A complete range of sofas, end units, chaise longue, sunbeds, armchairs, chairs, tables and complements which have been developed from solid teak structures with a special antique grey finish, which gives the wood a particular lived-in aspect and silver-grey reflective quality.

Al vivere all'aria aperta è dedicata Gio, la serie dall'accento classico contemporaneo disegnata da Antonio Citterio. Una famiglia completa di divani, elementi terminali, chaise longue, lettini, poltrone, sedie, tavoli e complementi che si sviluppano a partire da strutture in massello di teak nella speciale finitura antique grey, che conferisce al legno un particolare aspetto vissuto con riflessi grigio argento.

The various types of sofas, end units and chaise longue can be assembled to form linear, corner and peninsula seating. All elements have a basic structure of wooden slats where backrests and armrests, characterised by and interlacing of tortora ribbons, can be easily inserted.

Da un punto di vista formale le varie tipologie di divani, elementi terminali e chaise longue, tutti accostabili per formare sedute lineari, angolari e a penisola, prevedono una struttura di base a doghe di legno sulla quale si innestano telai schienale e braccioli caratterizzati dall'intreccio di nastri di colore tortora.

## Gio

Antonio Citterio • 2016

Inspiration • 209



The seats are equipped with seat and back cushions which makes the Gio series particularly cosy and comfortable, and offer exclusive colour combinations.

Le sedute sono completate da cuscini sedile e schienale che rendono Gio particolarmente accogliente e confortevole e offrono esclusivi abbinamenti cromatici.

To ensure a better insulation from the weather, all the padded elements have a polyester cover with waterproof treatment, and the fabrics are certified for resistance to weathering, UV rays, chlorine and sea spray.

Per garantire un migliore isolamento dalle intemperie, tutte le imbottiture sono rivestite con una fodera di poliestere con trattamento waterproof, mentre i tessuti sono certificati per resistenza agli agenti atmosferici, ai raggi UV, all'acqua clorata e alla salsedine.

## Gio

### Antonio Citterio • 2016

Inspiration • 209

The particular type of structure of Gio allows for easily disassemble the various components, so to reduce the space needed to store the products in winter.

Questa particolare tipologia di struttura consente di disassemblare in maniera molto semplice i vari componenti, riducendo così i volumi nel caso in cui si renda necessario stoccare il prodotto nel periodo invernale.



## Sofas

### Divani

#### G0203

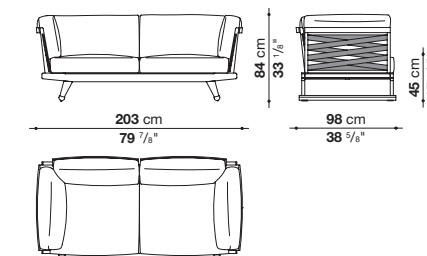

#### G0238

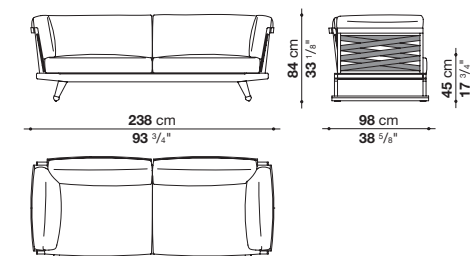

## Central elements

### Elementi centrali

#### G0192C

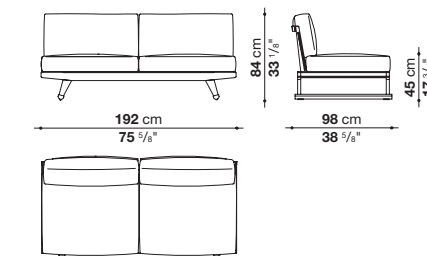

#### G0227C

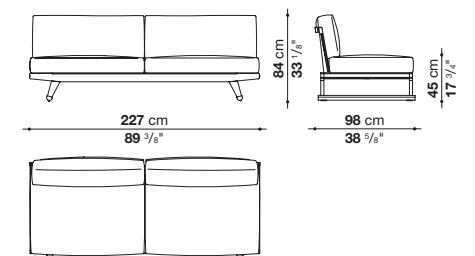

#### \* G0192CD

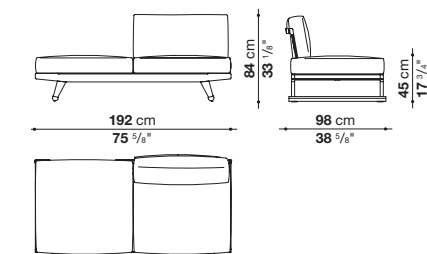

#### \* G0227CD

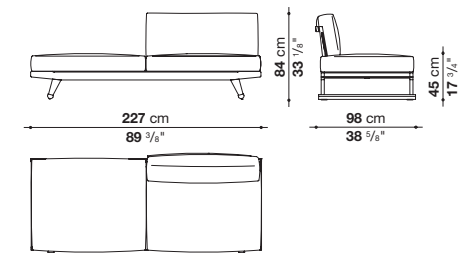

## Gio

### Antonio Citterio • 2016

Inspiration • 209

#### Terminal elements

Elementi terminali

\* G0197TD

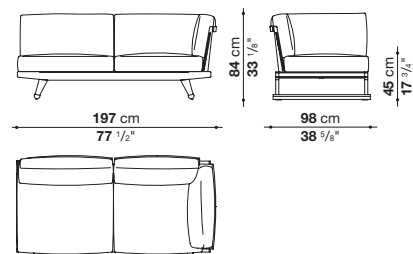

\* G0233TD

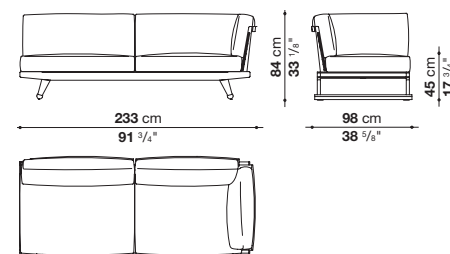

#### Corner elements

Elementi angolari

G0197AD

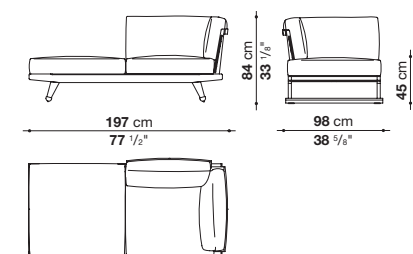

G0233AD

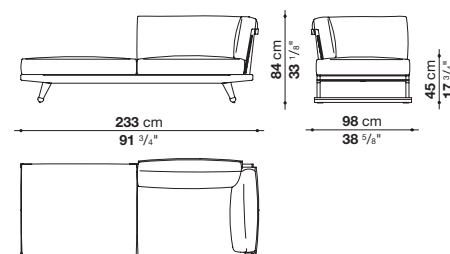

#### Chaise longue

Chaise longue

\* G0197LD

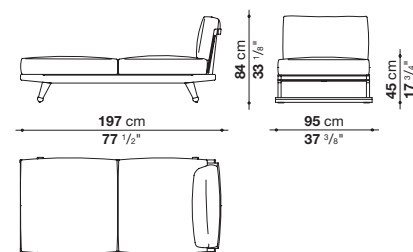

\* G0233LD

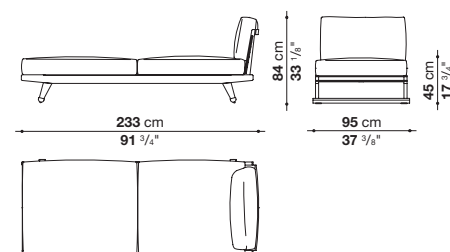

#### Chaise longue

Chaise longue

\* G0203LD

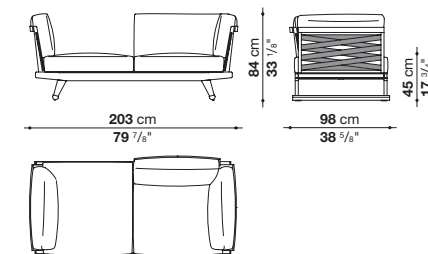

\* G0238LD

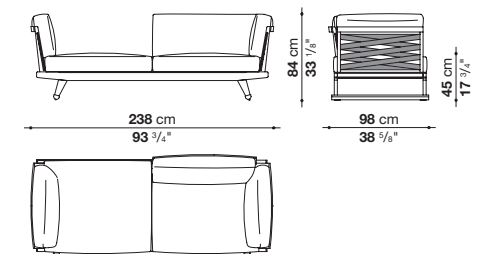

G0203L

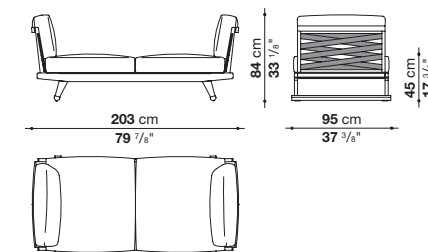

G0238L

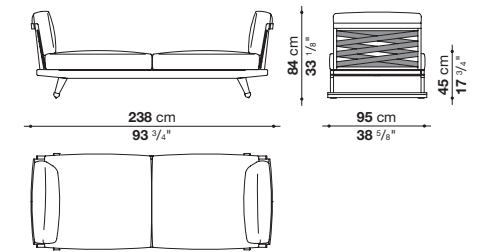

#### Sunbed with adjustable back

Letino con schienale regolabile

G0200L

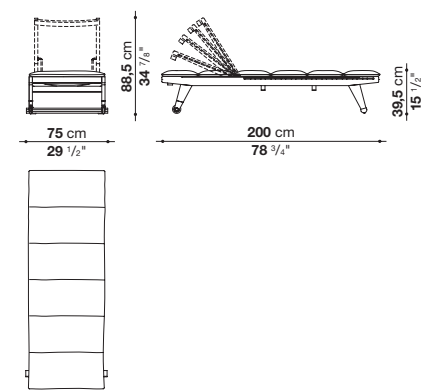

#### Armchair

Poltrona

G064

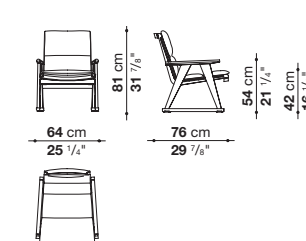

#### Chair

Sedia

G058

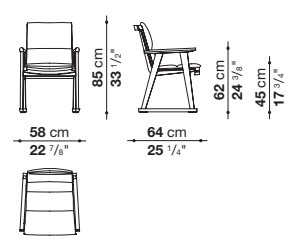

\* Elements available in right and left version. / Elementi disponibili nella versione destra e sinistra.  
The colours and materials shown are an indication. Images not in scale.  
La tonalità dei colori e dei materiali è indicativa. Immagini non in scala.

\* Elements available in right and left version. / Elementi disponibili nella versione destra e sinistra.  
The colours and materials shown are an indication. Images not in scale.  
La tonalità dei colori e dei materiali è indicativa. Immagini non in scala.

## Gio

### Antonio Citterio • 2016

Inspiration • 209

#### Benches

Panche

G065P

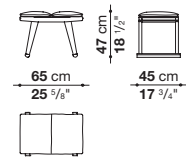

G0130P

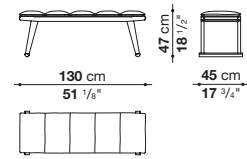

#### Small tables

Tavolini

TG06

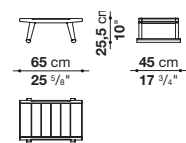

TG09

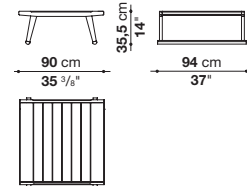

TG012

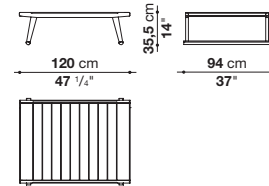

TG018

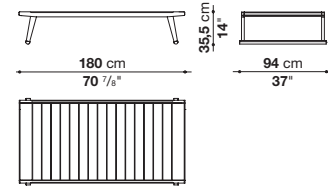

#### Low tables

Tavoli bassi

#### Tables

Tavoli

TG0220

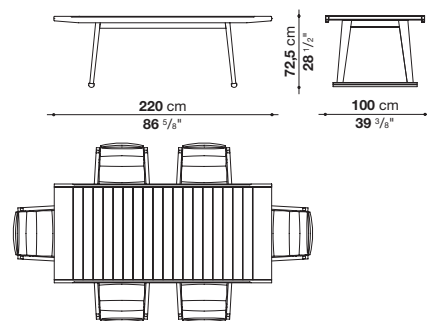

TG0280

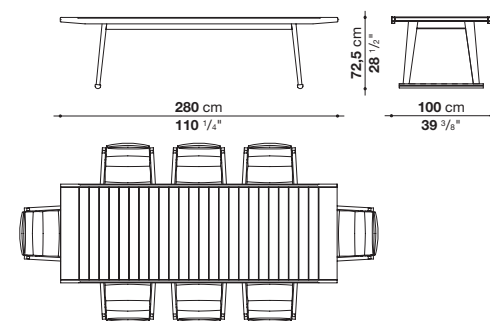

Frame and top	solid wood
Webbing	polypropylene
Upholstery	shaped polyurethane of different density, combination of Solotex fibre and visco-elastic polyurethane, cover in water repellent polyester fibre
Upholstery (G05S-G064-G0200L-G065P-G0130P)	high density polyester fibre
Reclining mechanism and zipper (G0200L)	electro polished stainless steel
Wheels (G0200L)	co-moulded thermoplastic material
Wheel supports (G0200L)	die-cast aluminium
Ferrules	thermoplastic material
Waterproof cover cloth	PES fabric coated on one side in PU

Struttura e piano	legno massello
Cinghiatura	polipropilene
Imbottitura	poliuretano sagomato a densità differenziata, combinazione fibra Solotex e poliuretano viscoelastico, fodera in fibra di poliestere con trattamento idrorepellente
Imbottitura (G05S-G064-G0200L-G065P-G0130P)	fibra di poliestere ad alta densità
Meccanismo reclinabile e cerniera (G0200L)	acciaio inox elettrolucidato
Ruote (G0200L)	materiale termoplastico co-stampato
Sostegno ruote (G0200L)	alluminio pressofuso
Puntali	materiale termoplastico
Telo di copertura impermeabile	tessuto PES monospalmato su un lato PU

#### Frame and top

Struttura e piano

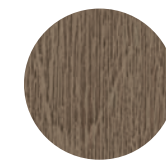

0492T  
antique grey teakwood  
teak antique grey

#### Webbing

Cinghiatura

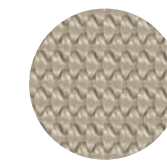

0113B  
tortora polypropylene  
polipropilene tortora

The colours and materials shown are an indication. Images not in scale.  
La tonalità dei colori e dei materiali è indicativa. Immagini non in scala.

# Hospes

## B&B Italia CR&S 2020

Inspiration • 304



Hospes is a dynamic complement that can be used in different ways and fits perfectly with different product families. Made in two sizes and three colors – overseas blue, stone, anthracite - it is based on a robust aluminum frame covered with an interlacing of waterproof ropes. On top, the interlacing hides a padding that provides support and comfort.

Hospes è una seduta estremamente versatile, che trova il suo luogo ideale in ogni ambiente. Un complemento dinamico che può essere utilizzato in modi diversi e si sposa perfettamente con diverse famiglie di prodotto. Realizzato in due dimensioni e tre colori - blu oltremare, sasso e antracite - si basa su un robusto telaio in alluminio rivestito con un intreccio di corde impermeabili. Nella parte superiore l'intreccio nasconde un'imbottitura che dona sostegno e comfort.

Internal frame	tubular aluminium and aluminium profiles
Upholstery	shaped polyurethane
Interlacing	polypropylene fibre braid
Ferrules	thermoplastic material

Telaio interno	tubolari e profilati d'alluminio
Imbottitura	poliuretano sagomato
Intreccio	treccia in fibra di polipropilene
Puntali	materiale termoplastico

### Ottomans Pouf

HE1

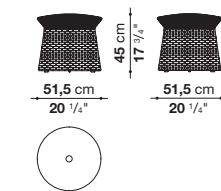

HE2

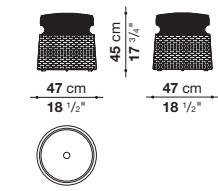

### Interlacing Intreccio



0835B  
overseas blue polypropylene  
blu oltremare polipropilene



0133A  
anthracite polypropylene  
antracite polipropilene

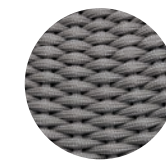

0244S  
stone polypropylene  
sasso polipropilene

The product is not available in U.K. market (British Standard) and California (TB117) / Il prodotto non è disponibile nel mercato UK (British Standard) and California (TB117). The colours and materials shown are an indication. Images not in scale. / La tonalità dei colori e dei materiali è indicativa. Immagini non in scala.

## Husk Outdoor

Patricia Urquiola • 2011

Inspiration • 294



Comfort and eco-sustainability are the key words for describing Husk Outdoor, designed by Patricia Urquiola. The collection is a tribute to softness, and just looking at these pieces is restful. Husk Outdoor features a hard shell made of Hirek®, a special plastic formed from recycled and recyclable polymers, and a set of soft cushions. The shell is white, while the fixed seat support is available painted in five colours. Cushions come in two versions, with larger sizes on the seat or on the back.

Comfort ed ecosostenibilità le parole chiave delle poltrone Husk Outdoor disegnate da Patricia Urquiola. La collezione è un inno alla morbidezza e invita al riposo già al primo sguardo. Husk Outdoor si caratterizza per una scocca rigida in Hirek®, una speciale plastica formata da polimeri riciclati e riciclabili, ed una serie di cuscini soffici. Bianco è il colore della scocca, mentre il supporto fisso è disponibile verniciato in cinque varianti. Due le versioni della cuscinatura, a scelta di dimensioni più generose sulla seduta o sullo schienale.

The dining chair version completes the Husk Outdoor collection, which meets a variety of size and functional needs. The shell is available only in white; the four legs are in white or black painted metal. The Husk Outdoor collection also includes two small tables: one with three spokes  $\varnothing$  45 cm, available in the same colour variants as the armchair bases; the other with four spokes  $\varnothing$  62,5 cm, already proposed in indoor spaces, joins the Outdoor collection with single colour versions painted white or black.

La tipologia sedia da pranzo completa la proposta Husk Outdoor ed è in grado di rispondere a necessità diverse per dimensione degli spazi e per funzioni. Unico è il colore della scocca, il bianco; le quattro gambe sono in metallo verniciato bianco oppure nero. Della collezione Husk Outdoor fanno parte anche due tavolini: uno a tre razze  $\varnothing$  45 cm, disponibile nelle stesse varianti di colore dei basamenti delle poltrone; l'altro a quattro razze  $\varnothing$  62,5 cm, già proposto per spazi indoor, entra a far parte della collezione Outdoor con le versioni monocolori verniciato bianco o nero.



## Husk Outdoor

### Patricia Urquiola • 2011

Inspiration • 294

#### Armchairs

Poltrone

H2

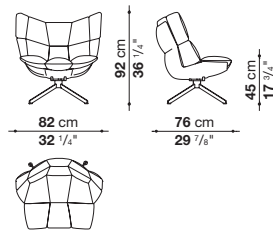

H4

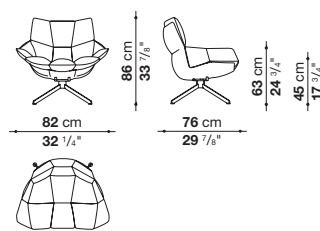

#### Ottoman

Pouf

HP1

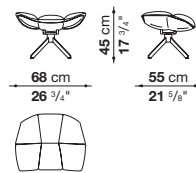

#### Small tables

Tavolini

HT

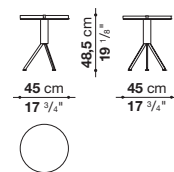

HT062

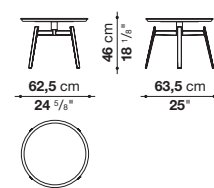

#### Tray

Vassoio

HT062V

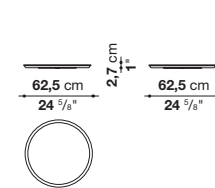

Shell	Hirek® plastic material
Upholstery	polyester fibre, cover in water repellent polyester fibre
Base-frame	aluminium profiles with polyester powder painting
Top (HT)	aluminium sheet with polyester powder painting
Top and tray (HT062-HT062V)	steel sheet with polyester powder painting
Support frame (HT062)	steel sheet and die-cast aluminium with polyester powder painting
Ferrules (HT062)	plastic material and stainless steel
Ferrules (HT062)	plastic material
Waterproof cover cloth	PES fabric coated on one side in PU
Cover	fabric in limited categories

Scocca	materiale plastico Hirek®
Imbottitura	fibra di poliestere, fodera in fibra di poliestere con trattamento idrorepellente
Basamento	profilati d'alluminio con verniciatura a polvere poliestere
Piano (HT)	lamiera d'alluminio con verniciatura a polvere poliestere
Piano e vassoio (HT062-HT062V)	lamiera d'acciaio con verniciatura a polvere poliestere
Struttura di sostegno (HT062)	lamiera d'acciaio e fusione d'alluminio con verniciatura a polvere poliestere
Puntali	materiale plastico e acciaio inossidabile
Puntali (HT062)	materiale plastico
Telo di copertura impermeabile	tessuto PES monospalmato su un lato PU
Rivestimento	tessuto in categorie limitate

#### Shell

Scocca

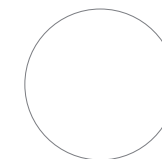

0010B  
white Hirek®  
Hirek® bianco

#### Small table base-frame and tray (HT062 - HT062V)

Basamento e vassoio tavolino

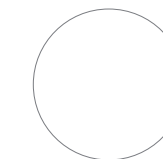

09010  
white painted  
verniciato bianco



01510  
black painted  
verniciato nero

#### Seatings base-frame and small table top (HT)

Basamento sedute e piano tavolino

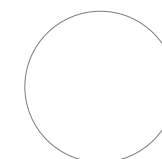

09010  
white painted  
verniciato bianco



01510  
black painted  
verniciato nero

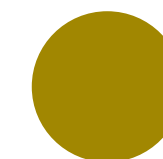

04510  
acid green painted  
verniciato verde acido



08110  
light blue painted  
verniciato azzurro



05710  
orange painted  
verniciato arancio

The colours and materials shown are an indication. Images not in scale.  
La tonalità dei colori e dei materiali è indicativa. Immagini non in scala.

## Husk Outdoor

### Patricia Urquiola • 2011

Inspiration • 294

Shell	high density polyurethane resin (Baydur®)
Upholstery	polyester fibre, needle polyester fibre section
Support frame	die-cast aluminium with polyester powder painting
Ferrules	plastic material
Waterproof cover cloth	PES fabric coated on one side in PU
Cover	fabric in limited categories

Scocca	resina poliuretanic ad alta densità (Baydur®)
Imbottitura	fibra di poliestere, inserto in fibra di poliestere agugliato
Struttura di sostegno	fusione d'alluminio con verniciatura a polvere poliestere
Puntali	materiale plastico
Telo di copertura impermeabile	tessuto PES monospalmato su un lato PU
Rivestimento	tessuto in categorie limitate

#### Chair

#### Sedia

HK1N

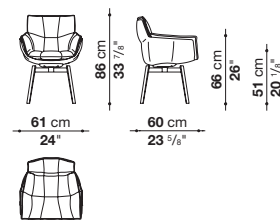

#### Shell

#### Scocca

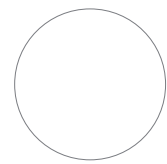

**0020B**  
white Baydur®  
Baydur® bianco

#### Support frame

#### Struttura di sostegno

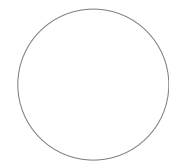

**09010**  
white painted  
verniciato bianco

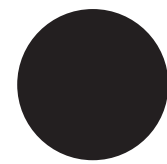

**01510**  
black painted  
verniciato nero

The colours and materials shown are an indication. Images not in scale.  
La tonalità dei colori e dei materiali è indicativa. Immagini non in scala.

#### Product items/Prodotti

#### Recommended combinations/Abbinamenti suggeriti



**08110**  
light blue  
painted  
verniciato  
azzurro



**09010**  
white  
painted  
verniciato  
bianco



**2433100**  
Eleo



**0010B**  
white Hirek®  
Hirek® bianco



**09010**  
white  
painted  
verniciato  
bianco



**2433570**  
Eleo



**04510**  
acid green  
painted  
verniciato  
verde acido



**2433200**  
Eleo



**0010B**  
white Hirek®  
Hirek® bianco



**09010**  
white  
painted  
verniciato  
bianco



**2433810**  
Eleo



**0010B**  
white Hirek®  
Hirek® bianco



**09010**  
white  
painted  
verniciato  
bianco



**2433200**  
Eleo



**0010B**  
white Baydur®  
Baydur® bianco



**09010**  
white  
painted  
verniciato  
bianco



**01510**  
black  
painted  
verniciato  
nero



**08110**  
light blue  
painted  
verniciato  
azzurro



**09010**  
white  
painted  
verniciato  
bianco



**04510**  
acid green  
painted  
verniciato  
verde acido



**05710**  
orange  
painted  
verniciato  
arancio

The colours and materials shown are an indication. Images not in scale.  
La tonalità dei colori e dei materiali è indicativa. Immagini non in scala.

## Hybrid

### Antonio Citterio • 2020

Inspiration • 117



After the great success of Ribes, Antonio Citterio developed some design ideas behind it and created Hybrid, an innovative new system of modular seating elements that it is so versatile it can be arranged into an almost infinite number of combinations.

The key role of the textile dimension stands out immediately, with upholsteries that cover completely the generous padding, the absolute protagonist. These are typical elements of indoor furnishings, which find with Hybrid an outdoor interpretation.

Hence the name of the collection, which is proposed as a real link between the inside and the outside of the house.

Hybrid represents in fact the perfect furnishing element for climates and spaces that are defined by a continuous blend of inside and outside environments, with rooms that open to an en-plein-air dimension, and for living spaces integrated into terraces and gardens. The combination of opposites happens not only visually, but also through the sense of touch. Hybrid guarantees in fact the typical comfort of traditional upholstered furniture for interiors, thanks to a new type of mattress seat conceived for outdoor furnishing.

Dopo il grande successo di Ribes, Antonio Citterio ne sviluppa alcuni spunti progettuali e nasce Hybrid, un nuovo sistema di sedute modulare ad alto tasso di innovazione, estremamente versatile e dalla componibilità pressoché infinita. Immediatamente balza all'occhio il ruolo chiave della dimensione tessile, che riveste completamente una generosa imbottitura, assoluta protagonista. Si tratta di elementi tipici dell'indoor, che con Hybrid arrivano con determinazione nell'outdoor. Da qui il nome della collezione, che si propone come vero e proprio anello di congiunzione tra l'interno e l'esterno della casa. Hybrid rappresenta infatti il perfetto elemento d'arredo per climi e spazi che si definiscono per la continuità tra dentro e fuori, ambienti naturalmente aperti a una dimensione en-plein-air, ma anche per spazi living integrati a terrazze o giardini. L'unione degli opposti non avviene soltanto attraverso la vista, bensì anche col tatto. Hybrid garantisce infatti il comfort tipico dei tradizionali imbottiti da interni, grazie a una seduta a materasso, estremamente soffice e accogliente, inedita per l'arredamento da esterni. La cuscinatura è infatti realizzata con materiale per imbottiture a diversa densità, studiato per accogliere



The cushions are actually made with paddings with different densities, carefully designed to pleasantly accommodate the body and support it at the same time, without sinking. The supporting structures are almost invisible, and the seat seems to float a few centimeters above the floor. The solid base is formed by a frame in extruded aluminum painted in the colours sage, clay and anthracite, and is completed by a platform with fiberglass slats. The backrest conceals an aluminum structure, covered with soft polyurethane, which is in turn covered with a padded sheath, completed with a cover in waterproof fabric. The platform is available in eight sizes and two depths, while the armrest and backrest come in two heights. To guarantee further comfort to the deeper seat, the low backrest can be raised with an additional headrest cushion. Additional cushions in various sizes enrich the range, offering countless design and chromatic solutions. The Hybrid collection also includes a series of new outdoor fabrics made with mélange polypropylene yarn in five colour variants that are accented by refined trims. Choices that confirm a decisive and elegant presence for interiors and outdoor spaces.

piacevolmente il corpo e sostenerlo allo stesso tempo, senza sprofondare. Le strutture portanti sono pressoché invisibili e la seduta sembra fluttuare a pochi centimetri dal pavimento. La base è formata da una solida struttura a cornice in estruso di alluminio verniciato nei colori salvia, argilla e antracite, completata da un pianale con doghe in fibra di vetro. Lo schienale nasconde una struttura di alluminio, rivestita di poliuretano morbido, a sua volta rivestito con una guaina imbottita, completata con un rivestimento in tessuto impermeabile. La piattaforma è disponibile in otto misure e due profondità, mentre il bracciolo e lo schienale prevedono due altezze. Per garantire ulteriore comodità alla seduta più profonda, lo schienale basso si può innalzare con un cuscino poggiatesta supplementare. Cuscini aggiuntivi in varie dimensioni arricchiscono la gamma, offrendo innumerevoli soluzioni progettuali e cromatiche. Fanno parte della collezione Hybrid una serie di nuovi tessuti outdoor realizzati con filato di polipropilene mélange in cinque varianti di colore che si sposano con raffinate bordature. Scelte che confermano una presenza decisa ed elegante per interni ed esterni.

# Hybrid

## Antonio Citterio • 2020

Inspiration • 117



All the objects in the Hybrid collection can be dismantled completely. At the end of the life cycle, each individual element can be separated and disposed of following the path best suited to each material. The particular type of structure of Hybrid allows for easily disassemble the various components, so to reduce the space needed to store the products in winter.

Tutti gli oggetti della collezione Hybrid sono completamente disassemblabili. Alla fine del ciclo di vita ogni singolo elemento si potrà separare e smaltire seguendo il percorso più adatto a ogni materiale. La sua particolare struttura consente di disassemblare in maniera molto semplice i vari componenti, riducendo così i volumi nel caso in cui si renda necessario stoccare il prodotto nel periodo invernale.

### Sofas (depth 90 cm.)

Divani (prof. 90 cm.)

9HY222

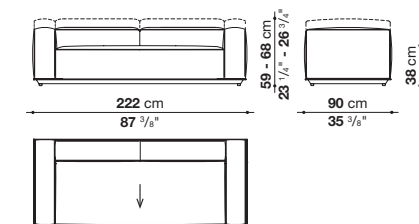

9HY310

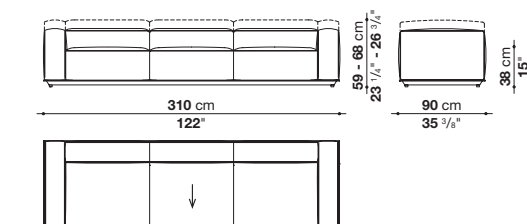

### Central elements (depth 90 cm.)

Elementi centrali (prof. 90 cm.)

9HY178C

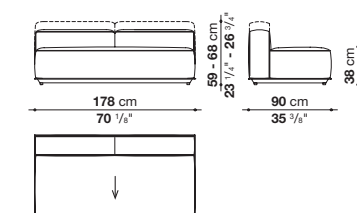

9HY266C

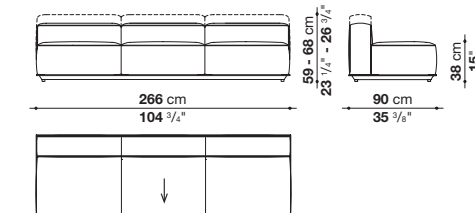

### Terminal elements (depth 90 cm.)

Elementi terminali (prof. 90 cm.)

9HY200T\_1

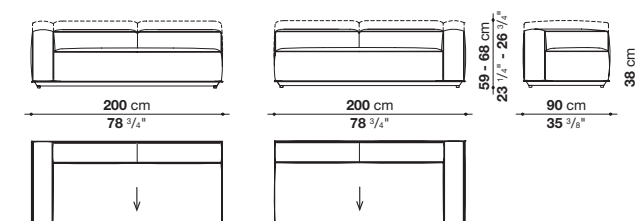

9HY200T\_2

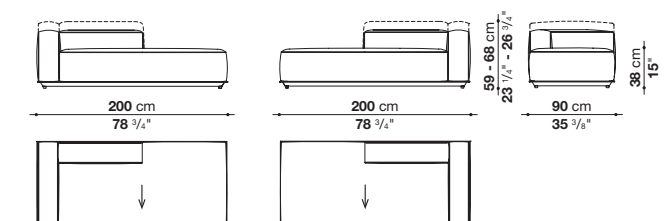

In the drawing the arrow shows the direction of the lines in case of cover with striped fabrics. / Nel disegno la freccia indica la direzione delle righe in caso di rivestimento con tessuti rigati. The colours and materials shown are an indication. Images not in scale. / La tonalità dei colori e dei materiali è indicativa. Immagini non in scala.

## Hybrid

### Antonio Citterio • 2020

Inspiration • 117

Corner elements (depth 90 cm.)  
Elementi angolari (prof 90 cm.)

9HY178A\_1

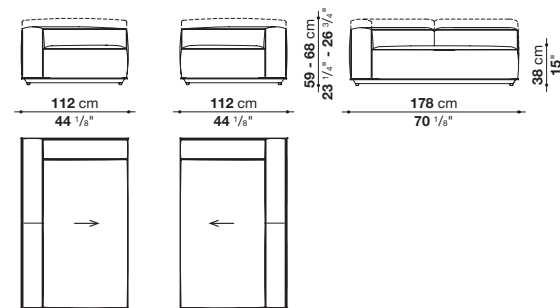

9HY178A\_2

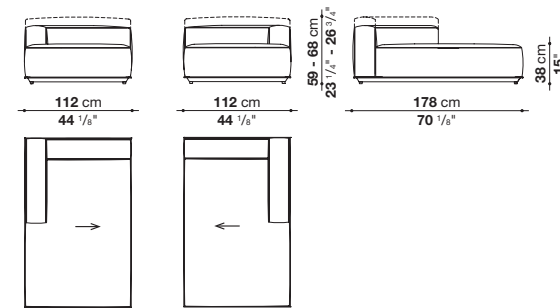

Bench (depth 90 cm.)  
Panca (prof. 90 cm.)

9HY178PA

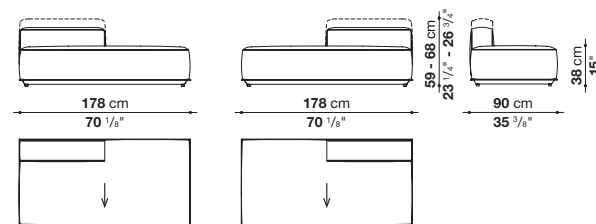

Central elements (depth 112 cm.)  
Corner terminali (prof. 112 cm.)

Central elements (depth 112 cm.)  
Corner terminali (prof. 112 cm.)

HY178C

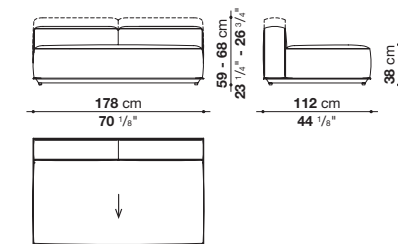

HY266C

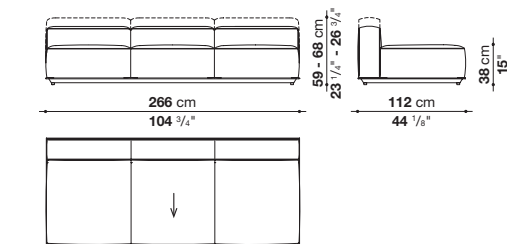

Terminal elements (depth 112 cm.)  
Elementi terminali (prof. 112 cm.)

HY200T\_1

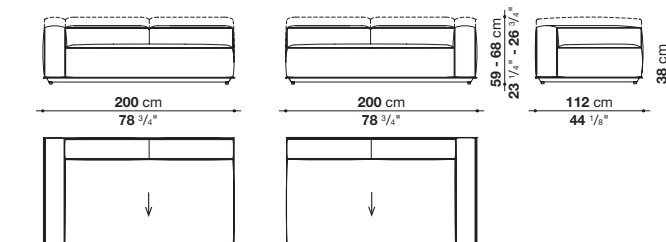

HY200T\_2

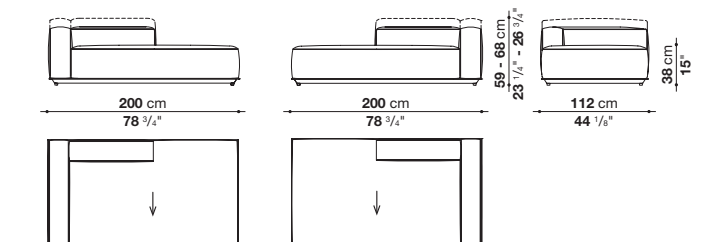

Corner elements (depth 112 cm.)  
Elementi angolari (prof. 112 cm.)

HY222A\_1

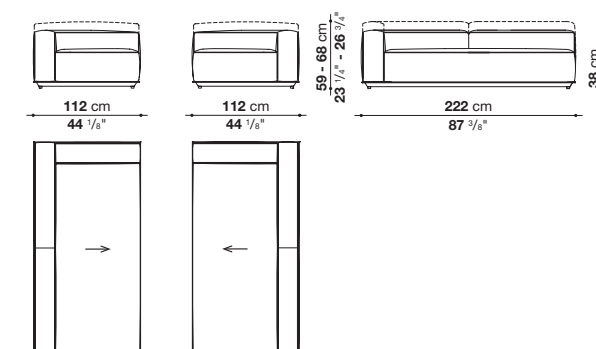

HY222A\_2

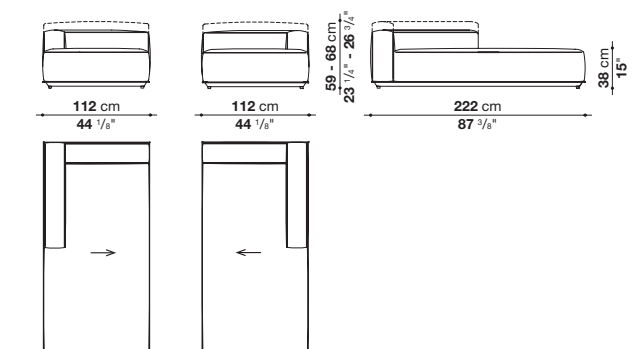

# Hybrid

## Antonio Citterio • 2020

Inspiration • 117

Bench (depth 112 cm.)  
Panca (prof. 112 cm.)

HY178APA

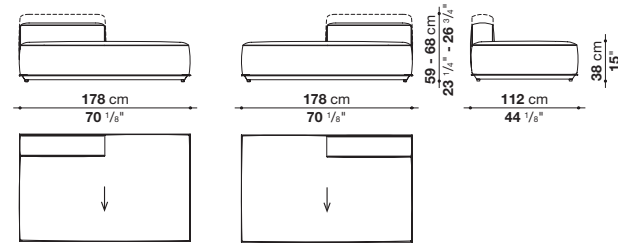

Chaise longue  
Chaise longue

HY134L

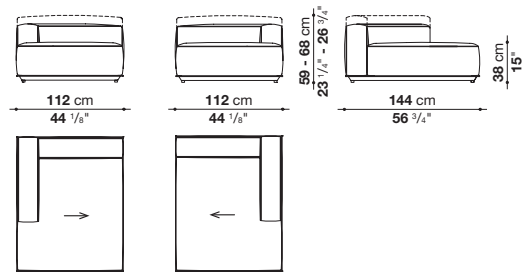

HY134L\_2

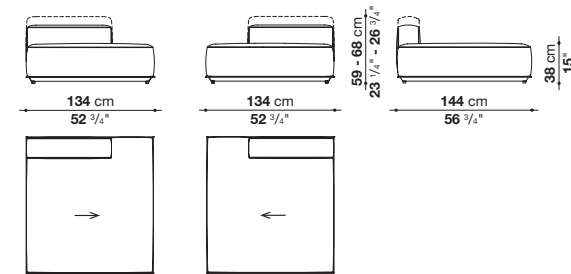

HY200L

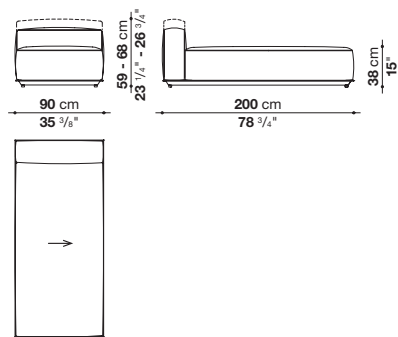

Ottomans  
Pouf

HY90P

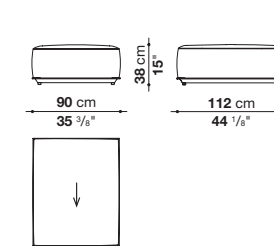

HY178P

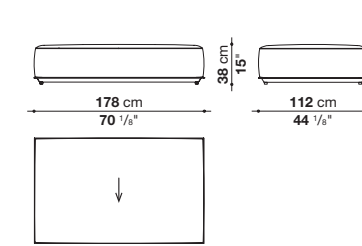

9HY112P

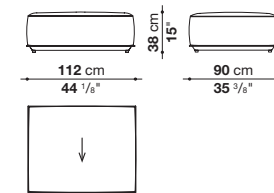

HY134PQ

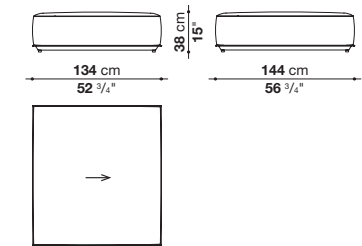

9HY178P

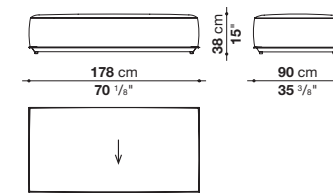

# Hybrid

## Antonio Citterio • 2020

Inspiration • 117

Frame	die-cast aluminium and extrusions with polyester powder painting
Upholstery	shaped polyurethane, cover in water repellent polyester fibre
Slats	glass fibre
Ferrules	thermoplastic material
Waterproof cover cloth	PES fabric coated on one side in PU
Cover	fabric in limited categories (with profile)

Struttura	pressofusione ed estrusi d'alluminio con verniciatura a polvere poliestere
Imbottitura	poliuretano sagomato, fodera in fibra di poliestere con trattamento idrorepellente
Doghe	fibra di vetro
Puntali	materiale termoplastico
Telo di copertura impermeabile	tessuto PES monospalmato su un lato PU
Rivestimento	tessuto in categorie limitate (con profilo)

### Product compositions/Esempi di composizioni

#### Recommended combinations/Abbinamenti suggeriti



2601403 Saturno	2601151 Saturno	0082N natural profile profilo naturale	0236B anthracite painted verniciato antracite



2601377 Saturno	0082N natural profile profilo naturale	0427S sage painted verniciato salvia



601151 Saturno	2601258 Saturno	0082N natural profile profilo naturale	0236B anthracite painted verniciato antracite



2570810 Elisir	2601800 Saturno	0095B blue profile profilo blu	0236B anthracite painted verniciato antracite

#### Frame

##### Struttura

0427S sage painted verniciato salvia	0750A clay painted verniciato argilla	0236B anthracite painted verniciato antracite

#### Seat and back cushion profile

##### Profilo cuscino sedile e schienale

0041E cream white bianco panna	0082N natural naturale	0054G dark grey grigio scuro	00585A acquamarine acquamarina	0075R red rosso	0095B blue blu



2601800 Saturno	570815 Elisir	0054G dark grey profile profilo grigio scuro	0236B anthracite painted verniciato antracite



2570410 Elisir	2570420 Elisir	0082N natural profile profilo naturale	0236B anthracite painted verniciato antracite

Kaleidos  
B&B Italia CR&S 2018  
Inspiration • 328

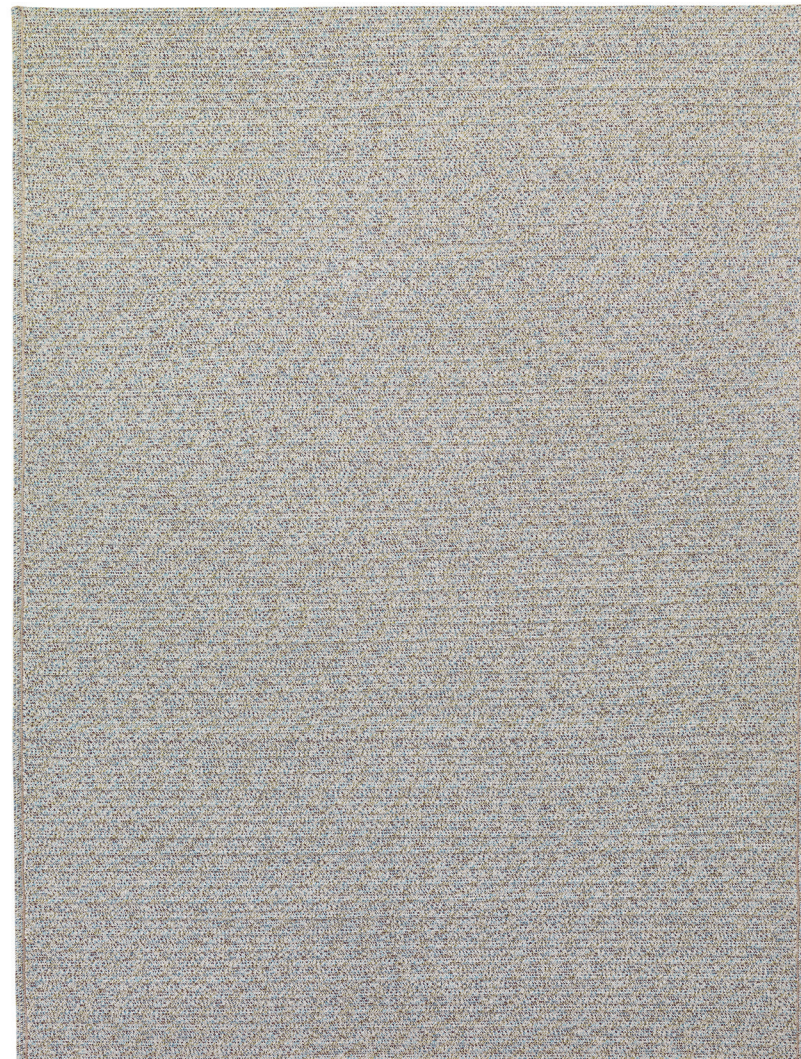

Carpet	braided ropes with dyed Olyna FLYER® fibre
Composition	100% polyolefin

Tappeto	corde intrecciate con fibra tinta Olyna FLYER®
Composizione	100% poliolefine

Carpets  
Tappeti

TKA01

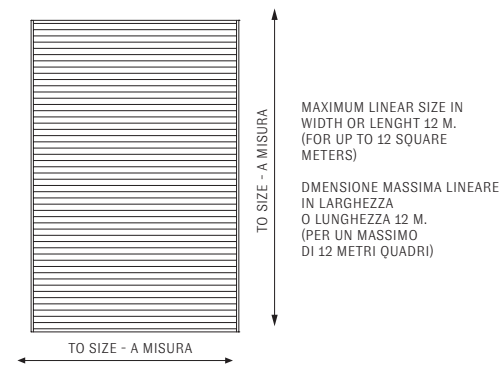

TKA200

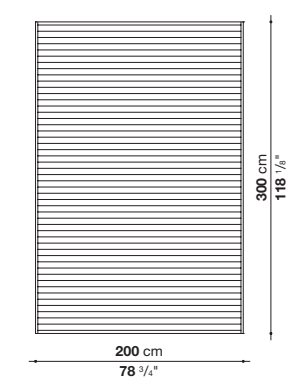

TKA250

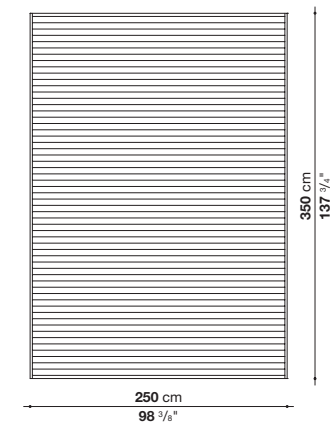

TKA300

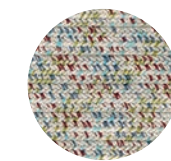
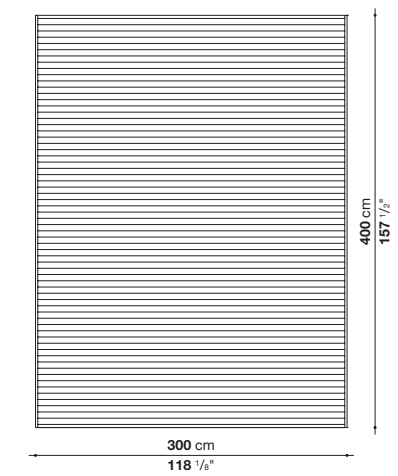

0021M  
multicolour polyolefin  
multicolore poliolefine

The colour and material shown are an indication. Image not in scale.  
La tonalità del colore e del materiale è indicativa. Immagine non in scala.



**Kyra**  
B&B Italia CR&S · 2019  
Inspiration • 324

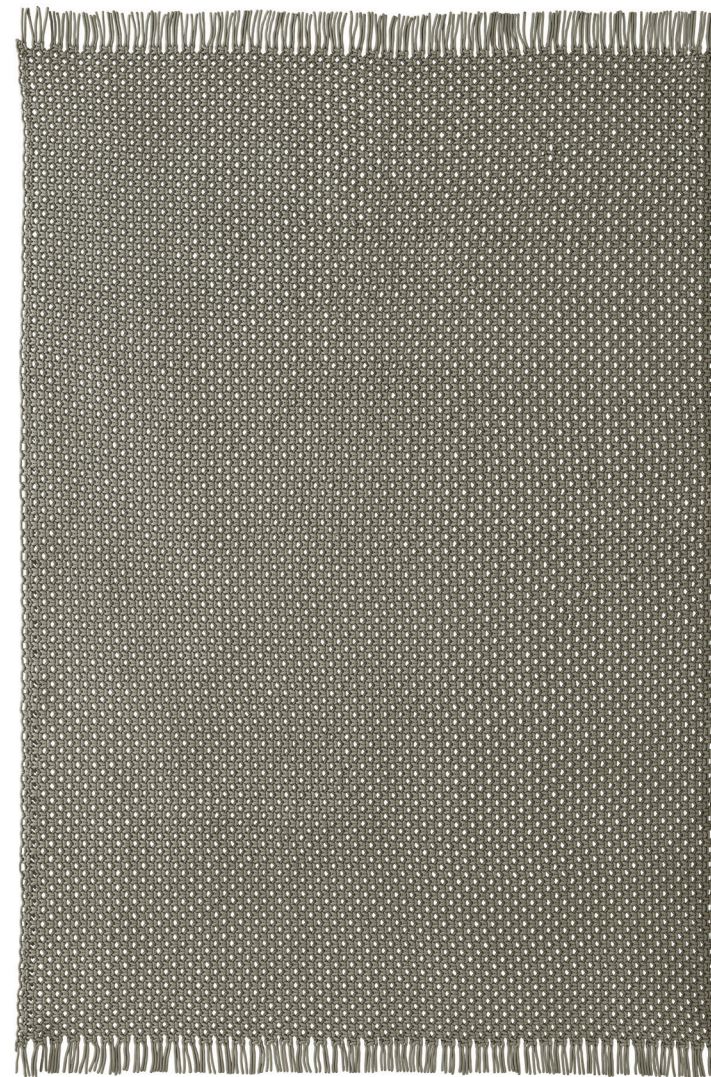

Carpet	braided ropes with dyed Olyna FLYER® fibre
Composition	100% polyolefin

Tappeto	corde intrecciate con fibra tinta Olyna FLYER®
Composizione	100% poliolefine

Carpet  
Tappeto

TY200

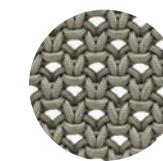
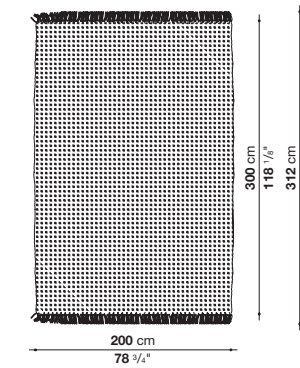

0025T  
stone polyolefin  
sasso poliolefine

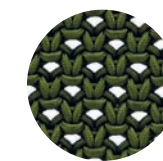

0045V  
olive green polyolefin  
verde oliva poliolefine

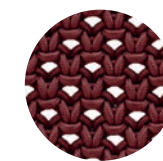

0074B  
violet polyolefin  
viola poliolefine

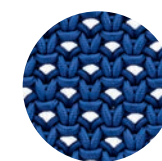

0094R  
blue royal polyolefin  
blu royal poliolefine

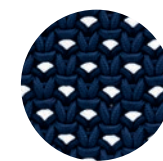

0083B  
overseas blue polyolefin  
blu oltremare poliolefine



0064A  
anthracite polyolefin  
antracite poliolefine

The colours and materials shown are an indication. Images not in scale.  
La tonalità dei colori e dei materiali è indicativa. Immagini non in scala.

## Link Outdoor

### Jakob Wagner · 2009

Inspiration • 284



One-of-a-kind, this piece has been moulded in a continuous, joint-free shape: Link Outdoor stands out for its “soft” material and sensual shape. The material makes you want to reach out and touch its smooth surface. An interestingly shaped dining table dominates the room: Danish designer Jakob Wagner places his pure, contemporary mark on this room, typical of northern design. The table is made in a single piece and there are no hooks or joints. Made from a practical technological material: a special type of Cristalplant Outdoor® ensures that it is suitable for outdoor use. It is a resin, in a fluid form that is moulded into the desired shape, a concept in line with B&B Italia’s production philosophy for upholstered furniture. Cristalplant Outdoor® has a velvety smooth surface, an effective soft-touch surface that feels wonderful.

Pezzo unico, plasmato, continuo, privo di giunti: Link Outdoor si distingue per la sua matericità “morbida”, per la sensualità della sua forma e del suo materiale che suscitano il desiderio di sfiorarne la superficie levigata. Un tavolo da pranzo sinuoso, plastico, protagonista dello spazio: lo firma il designer danese Jakob Wagner che ci mette il suo segno purissimo e contemporaneo, tipico del design nordico. Il tavolo è realizzato in un unico stampo e non prevede l'utilizzo di agganci e giunture. Tecnologico e pratico il materiale che lo compone: una speciale miscela in Cristalplant Outdoor® che assicura l'utilizzo da esterni e da interno. La resina, è in forma fluida e viene lavorata con stampi, concetto in linea con la filosofia di produzione degli imbottiti di B&B Italia. Al tatto Cristalplant Outdoor® si caratterizza per la superficie vellutata con effetto soft-touch di notevole impatto sensoriale.

Top and legs	Cristalplant Outdoor® (natural mineral filler of phosphate of aluminium with polyester acrylate resin)	Piano e gambe	Cristalplant Outdoor® (carica minerale naturale di idrato d'alluminio con resina poliestere acrilata)
Waterproof cover cloth	PES fabric coated on one side in PU	Telo di copertura impermeabile	tessuto PES monospalmato su un lato PU

### Tables

#### Tavoli

TLK190N

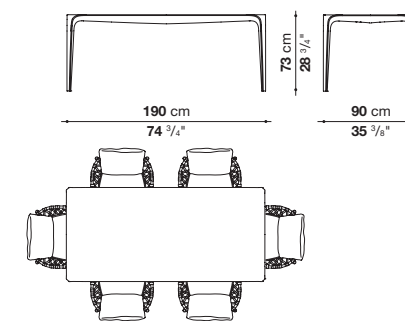

TLK250N

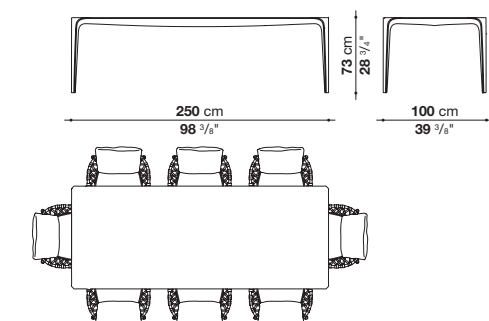

### Top and legs

#### Piano e gambe

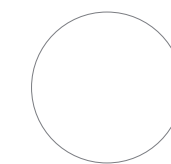

0101G

white Cristalplant Outdoor®  
Cristalplant Outdoor® bianco

The colour and material shown are an indication. Image not in scale.  
La tonalità del colore e del materiale è indicativa. Immagine non in scala.

## Mirto Outdoor

Antonio Citterio • 2013

Inspiration • 181



A classic is born. It expresses Antonio Citterio's stable elegance. Different types of seat: chairs, armchairs and a sunbeds are included in the collection.

The folding armchair revisits the classic shape of the director's chair, with exclusive details.

Nasce un classico che esprime l'eleganza stabile e riconoscibile del suo autore. Fanno parte della collezione diverse tipologie di seduta: sedie, poltrone, lettini con schienale reclinabile ed una poltroncina pieghevole che rielabora il lessico della classica tipologia da regista, con dettagli accurati.

## Mirto Outdoor

Antonio Citterio • 2013

Inspiration • 181



Details like the light aluminium structure, the mesh in Batyline® Canatex, in which hemp fibre confers a more rustic natural look compared to plastics that are usually used in this sector. The edges are cut, sewn and glued masterfully around the profiles to create minimal décor.

Dettagli come la struttura leggera in alluminio, la rete in Batyline® Canatex, la cui fibra di canapa conferisce una mano più rustica e naturale rispetto alle plastiche in uso nel settore. I bordi tagliati, cuciti e incollati con sapienza seguono i profili e dettano il decoro minimal.

## Mirto Outdoor

Antonio Citterio • 2013

Inspiration • 181



All sizes of tables, low tables, small tables and consoles have the same frame and top in painted aluminium, in Calacatta white porcelain stoneware or in enamelled lava stone with anthracite, clay, sage decoration. The quality and attention to detail make Mirto a collection that is made to last.

Tavoli, tavoli bassi, tavolini e console hanno la stessa struttura e top in lamiera verniciata, in gres porcellanato bianco Calacatta o in pietra lavica smaltata con decoro antracite, argilla, o salvia. L'aspetto qualitativo e la cura dei dettagli fanno di Mirto una collezione fatta per durare nel tempo.

## Mirto Outdoor

### Antonio Citterio • 2013

Inspiration • 181



In 2019 the Mirto collection is also being expanded to include new designs and finishes starting with the folding director's chair now in ecru canvas with natural thick leather armrests and a die-cast aluminium frame in the new colours, clay and sage. There is also a series of very innovative dining, tables, low tables, small tables and console in several sizes that reproduce the collection's minimalist design elements with a fresh take on colours and decorations.

La collezione Mirto si amplia nel 2019 con nuove proposte e finiture, a partire dalla sedia regista pieghevole ora presentata con un rivestimento in tela ecru con braccioli in cuoio naturale e struttura in pressofusione di alluminio nei nuovi colori argilla e salvia. La grande novità è rappresentata dalla serie di tavoli da pranzo, tavoli bassi, tavolini e console in varie dimensioni che riprendono il disegno essenziale di quelli già parte della collezione, ma introducono i temi del colore e del decoro.

The die-cast aluminium frame comes in three new varnishes - clay, sage and anthracite - and the table tops are made of black lava stone laid out in designs based on traditional Sicilian lace in the three different frame shades.

A really innovative technique has been used to manufacture the decorative tiles using a special material obtained by crushing recycled electronic equipment screens which is then applied to the surface of the tiles using an exclusive production process.

Le strutture in pressofusione d'alluminio sono verniciate nei colori argilla, salvia e antracite, mentre i piani sono realizzati con piastrelle di pietra lavica smaltata con decori che riproducono il disegno di un pizzo siciliano tradizionale da abbinare alle tre tonalità delle strutture. La tecnica di stampa delle piastrelle è altamente innovativa e utilizza per il decoro uno speciale materiale ottenuto dalla frantumazione del vetro di monitor e strumenti elettronici dismessi, poi applicato alla superficie delle piastrelle tramite un esclusivo processo di lavorazione.

Mirto Outdoor  
Antonio Citterio • 2013  
Inspiration • 181

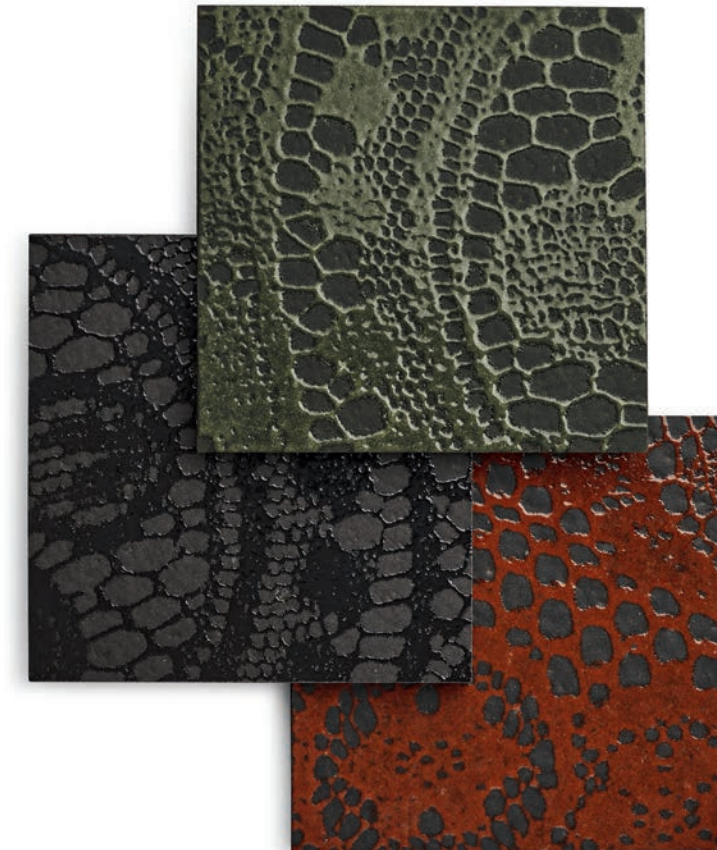

# Mirto Outdoor

## Antonio Citterio • 2013

Inspiration • 181

Sunbeds with adjustable back  
 Lettini con schienale regolabile

MI74CL

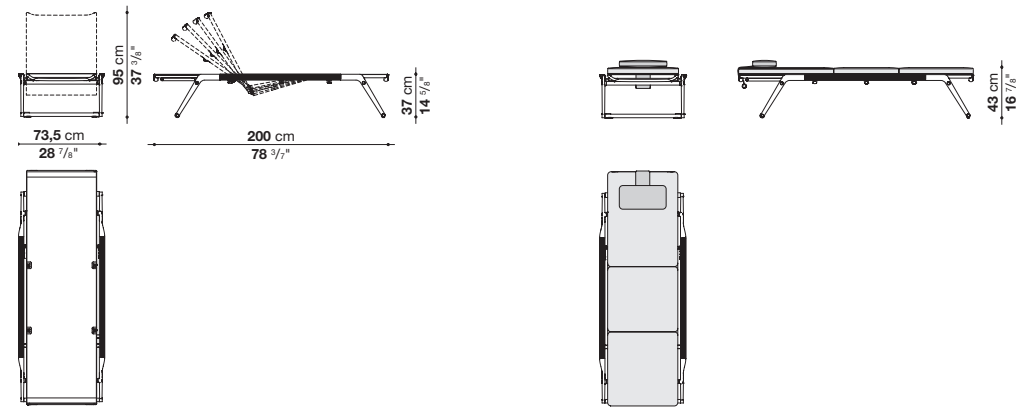

MI74CL\_P

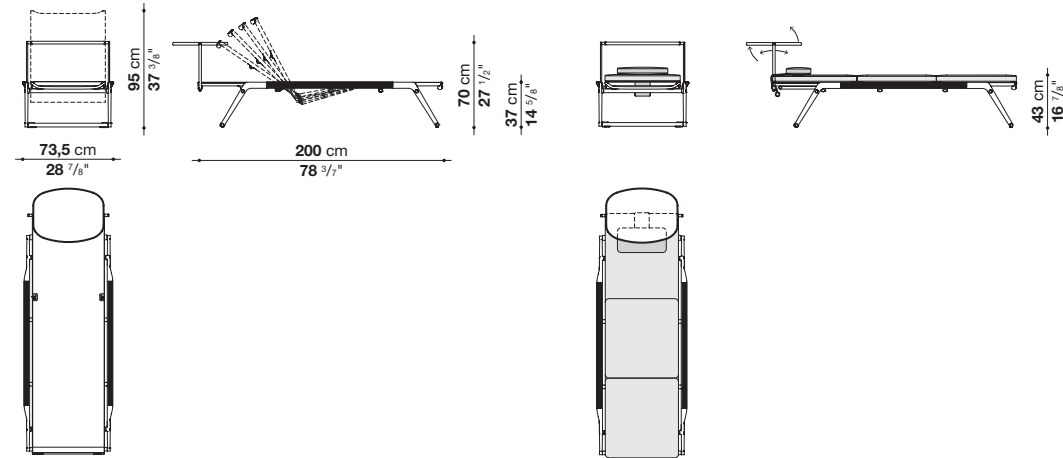

Sunbeds with adjustable back  
 Lettini con schienale regolabile

MI200CL

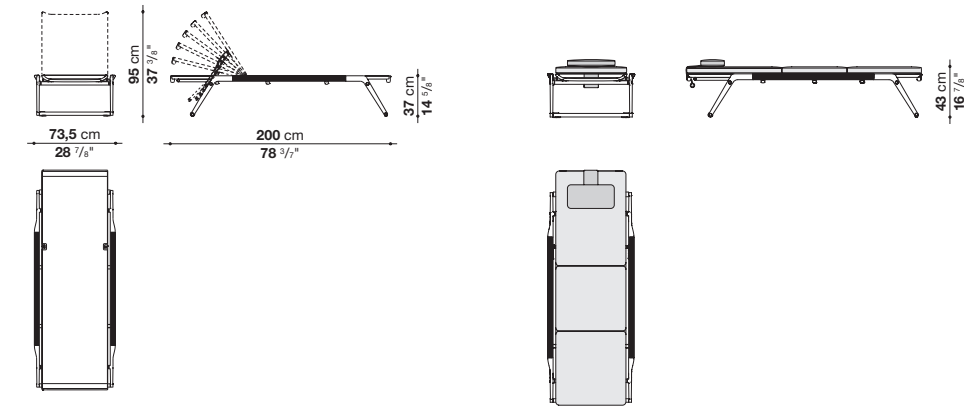

MI200CL\_P

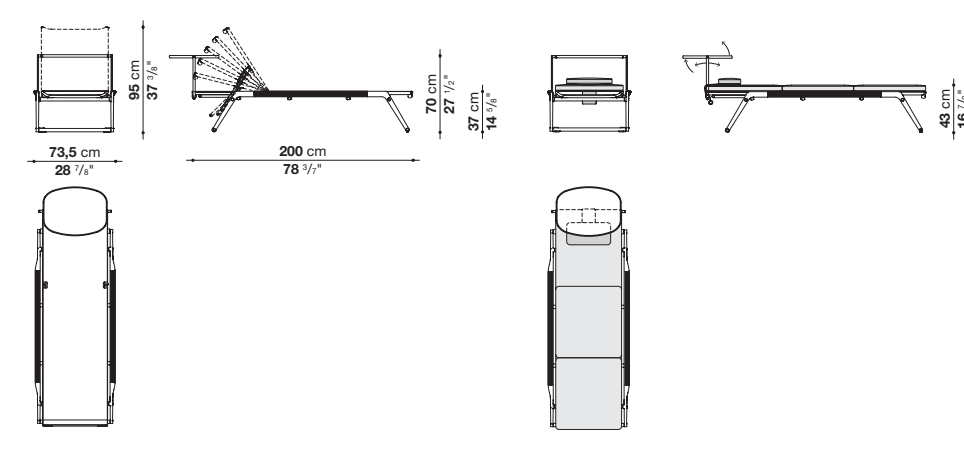



## Mirto Outdoor

### Antonio Citterio • 2013

Inspiration • 181

Folding small armchair  
Poltroncina pieghevole

MI59N - MI59SR

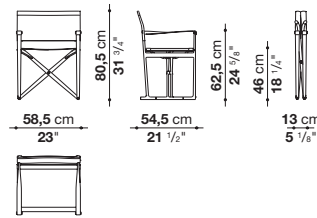

Small armchair  
Poltroncina

MI65P

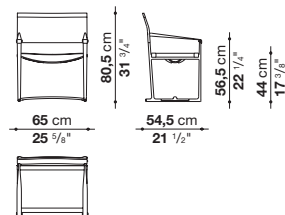

Chair  
Sedia

MI58S

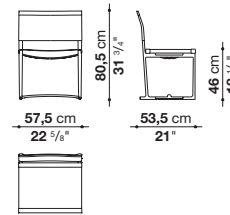

Frame	die-cast aluminium and extrusions with polyurethane painting
Seat and back	Stige mesh in Batyline® Canatex
Seat and back (MI59N)	fabric in limited categories
Edges and armrests	Batyline® Keops
Armrests (MI59N)	waterproof thick leather
Wheels (M200CL-MI74CL)	acetal resin
Hinges (M200CL-MI74CL)	micro die-cast stainless steel
Handrail (M200CL-MI74CL)	vulcanised thermoplastic material
Upholstery (small mattress and headrest)	shaped polyurethane polyester fibre cover
Ferrules	thermoplastic elastomer
Waterproof cover cloth (M200CL-MI74CL)	PES fabric coated on one side in PU

Struttura	pressofusione ed estrusi d'alluminio con verniciatura poliuretanicca
Sedile e schienale	rete Stige in Batyline® Canatex
Sedile e schienale (MI59N)	tessuto in categorie limitate
Bordi e braccioli	Batyline® Keops
Braccioli (MI59N)	cuoio impermeabile
Ruote (M200CL-MI74CL)	resina acetamica
Cerniere (M200CL-MI74CL)	microfusione d'acciaio inossidabile
Corrimano (M200CL-MI74CL)	materiale termoplastico vulcanizzato
Imbottitura (materassino e poggiatesta)	poliuretano sagomato, fodera in fibra di poliestere
Puntali	elastomero termoplastico
Telo di copertura impermeabile (M200CL-MI74CL)	tessuto PES monospalmato su un lato PU

Frame  
Struttura

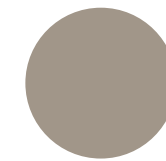

0380T  
tortora painted  
verniciato tortora

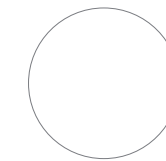

0186V  
white painted  
verniciato bianco

Edge and armrests  
Bordi e braccioli

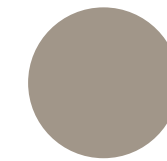

0280T  
tortora colour  
color tortora

Seat and back  
Sedile e schienale

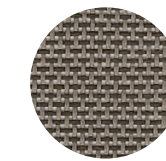

2445280  
Stige tortora  
Stige tortora



2445102  
natural white Stige  
Stige bianco naturale

Frame (MI59N)  
Struttura

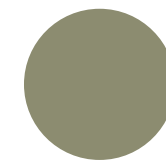

0427S  
sage painted  
verniciato salvia

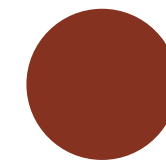

0750A  
clay painted  
verniciato argilla

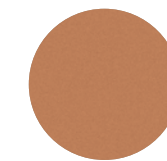

0136N  
natural color  
colore naturale

Armrests (MI59N)  
Braccioli

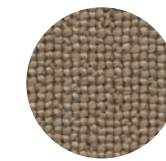

2572102  
natural Laguna  
Laguna naturale

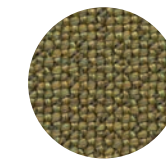

2822401  
moss green Lamar  
Lamar verde muschio

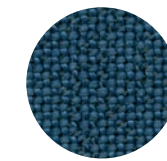

2822890  
Sea blue Lamar  
Lamar blu mare

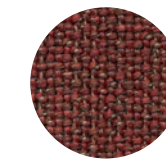

2822760  
Lamar argilla  
clay Lamar

The colours and materials shown are an indication. Images not in scale.  
La tonalità dei colori e dei materiali è indicativa. Immagini non in scala.

## Mirto Outdoor

### Antonio Citterio • 2013

Inspiration • 181

Tables\_painted or porcelain stoneware top  
Tavoli\_piano verniciato o in gres porcellanato

MI150TQ - MI150TQG

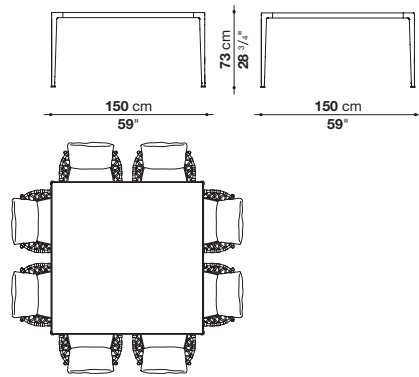

MI160T - MI160TG

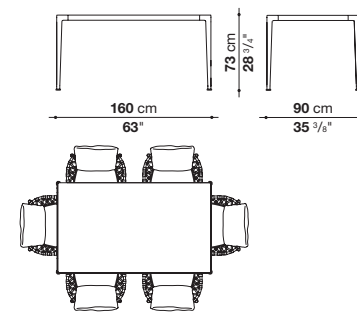

TM0222

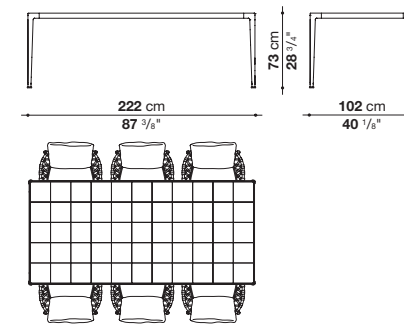

TM0222\_6

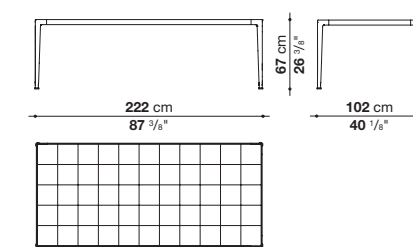

MI220T - MI220TG

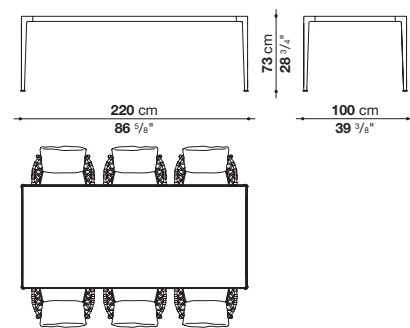

MI250T - MI250TG

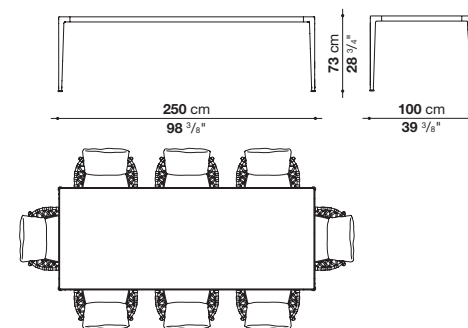

MI150\_6 - MI150\_6G

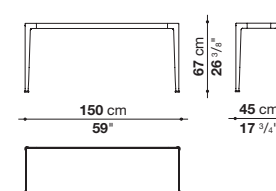

MI200\_6 - MI200\_6G

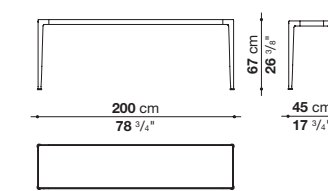

MI250\_6 - MI250\_6G

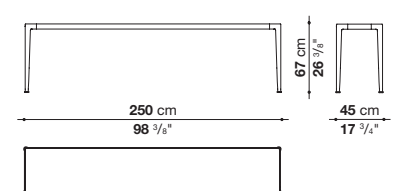

Tables\_enamelled lava stone with decoration top  
Tavoli\_piano in pietra lavica smaltata con decoro

TM0162Q

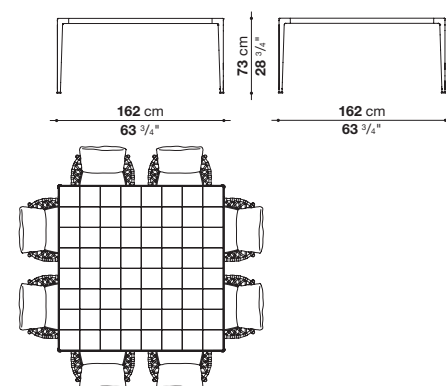

TM0162Q\_6

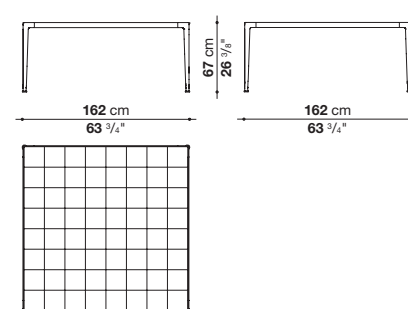

TM0162\_6

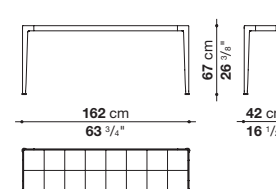

Consoles\_enamelled lava stone with decoration top  
Console\_piano in pietra lavica smaltata con decoro

## Mirto Outdoor

### Antonio Citterio • 2013

Inspiration • 181

Low tables\_painted or porcelain stoneware top  
Tavoli bassi\_piano verniciato o in gres porcellanato

MI90Q\_4 - MI90Q\_4G

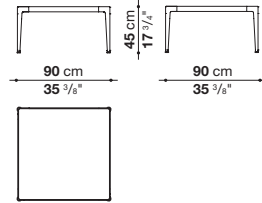

MI120Q\_4 - MI120Q\_4G

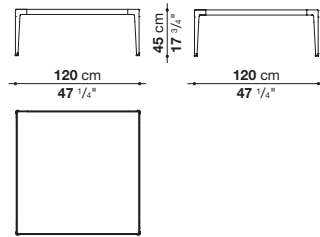

MI120\_4 - MI120\_4G

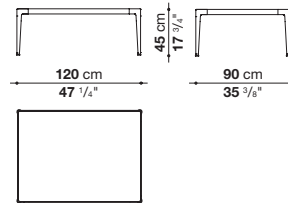

Small tables\_painted top  
Tavolini\_piano verniciato

MI54T

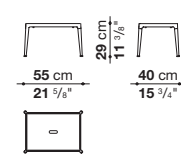

MI55\_5

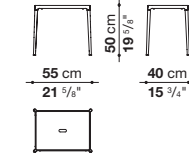

MI180\_4 - MI180\_4G

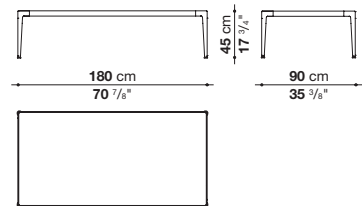

MI200\_4 - MI200\_4G

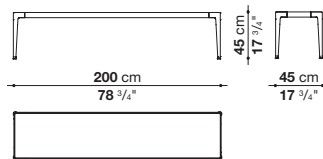

Small table\_enamelled lava stone with decoration top  
Tavolino\_piano in pietra lavica smaltata con decoro

TMO82Q\_4

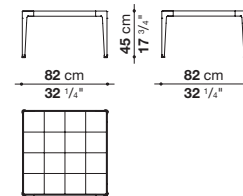

Low table\_enamelled lava stone with decoration top  
Tavolo basso\_piano in pietra lavica smaltata con decoro

TMO162\_4

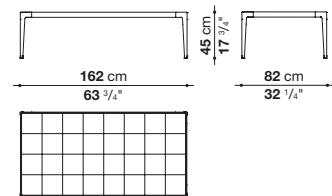

## Mirto Outdoor

### Antonio Citterio • 2013

Inspiration • 181

Frame	die-cast aluminium and extrusions with polyurethane painting
Top	aluminium sheet with polyurethane painting, porcelain stoneware or enamelled lava stone
Top (MI54T - MI55_5)	die-cast aluminium with polyurethane painting
Ferrules	thermoplastic elastomer
Waterproof cover cloth	PES fabric coated on one side in PU

Struttura	pressofusione ed estrusi d'alluminio con verniciatura poliuretana
Piano	lamiera d'alluminio con verniciatura poliuretana, gres porcellanato o pietra lavica smaltata su piano in alluminio
Piano (MI54T - MI55_5)	pressofusione d'alluminio con verniciatura poliuretana
Puntali	elastomero termoplastico
Telo di copertura impermeabile	tessuto PES monospalmato su un lato PU

#### Tables, low table, small table and console frame

Struttura tavoli, tavolo basso, tavolino e console

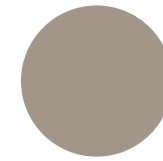

0380T  
tortora painted  
verniciato tortora

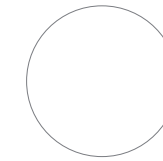

0186V  
white painted  
verniciato bianco

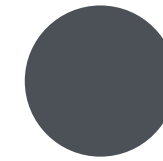

0236B  
anthracite painted  
verniciato antracite

#### Tables, low table, small table and console top

Piano tavoli, tavolo basso, tavolino e console

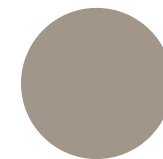

0380T  
tortora painted  
verniciato tortora

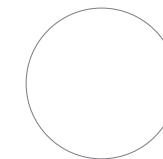

0186V  
white painted  
verniciato bianco

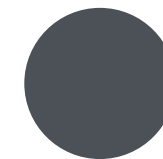

0236B  
anthracite painted  
verniciato antracite



0301B  
Calacatta white porcelain stoneware  
gres porcellanato bianco Calacatta

#### Top and frame (MI54T - MI55\_5)

Struttura e piano

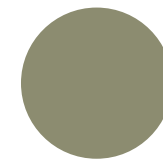

0427S  
sage painted  
verniciato salvia

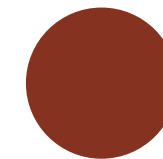

0750A  
clay painted  
verniciato argilla

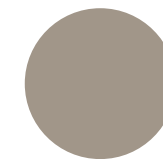

0380T  
tortora painted  
verniciato tortora

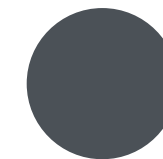

0236B  
anthracite painted  
verniciato antracite

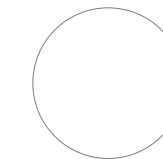

0186V  
white painted  
verniciato bianco

#### Frame and top matching in lava stone

Abbinamento struttura e piano in pietra lavica

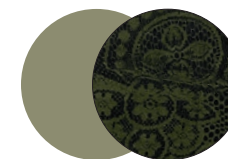

0427S / 0406V

sage painted / enamelled lava stone with green decoration  
verniciato salvia / pietra lavica smaltata con decoro salvia

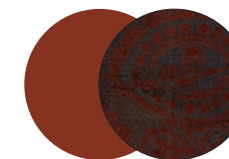

0750A / 0703A

clay painted / enamelled lava stone with clay decoration  
verniciato argilla / pietra lavica smaltata con decoro argilla



0236B / 0164A

anthracite painted / enamelled lava stone with anthracite decoration  
verniciato antracite / pietra lavica smaltata con decoro antracite

The colours and materials shown are an indication. Images not in scale.  
La tonalità dei colori e dei materiali è indicativa. Immagini non in scala.

## Nooch

Piero Lissoni • 2023

Inspiration • 5



Nooch is a modular seating system designed with great attention to comfort, compositional flexibility and sustainability.

Its key feature is the tubular structure in recycled aluminum, a light and strong material, completely recyclable. A choice inspired by simplicity, which recalls elementary tubular structures and ennobles them with a design that pays attention to every detail.

The intersection of the structural elements represents the iconic feature of this collection, with the particular elbow curve achieved by the way the aluminum bends.

Nooch è un sistema di sedute modulare progettato all'insegna del comfort, della flessibilità compositiva e della sostenibilità. La sua caratteristica fondamentale è la struttura tubolare in alluminio riciclato, materiale leggero e robusto, riciclabile all'infinito. Il disegno richiama strutture tubolari elementari nobilitandole attraverso una progettazione attenta a ogni singolo dettaglio e un'elegante finitura semilucida. L'elemento iconico della collezione è riconoscibile nel punto di incrocio degli elementi strutturali, con una particolare curva a gomito ottenuta dalla piegatura dei tubolari.

Nooch is a system that offers the possibility of creating infinite combinations from two base modules: a rectangular one and a square one. That can be equipped with backrests and armrests. The modules can be arranged as free-standing units or attached firmly together by means of special interlocking joints so as to create a variety of configurations.

This is also possible due to a series of additional tables that can be inserted between the seats. With tops in serpentine stone or natural teak wood, with irregular slats, they are available in square,

Nooch si propone come un sistema che offre la possibilità di creare infinite combinazioni a partire da due moduli seduta: uno rettangolare e uno quadrato che possono essere dotati di schienali e braccioli. I moduli si possono disporre come unità free-standing oppure agganciare saldamente tra loro tramite speciali giunture così da creare le più svariate configurazioni.

Una serie di tavolini a ponte da poter inserire tra gli elementi offre una libertà compositiva ancora maggiore. Con piani in pietra serpentina o in teak naturale a doghe irregolari, sono disponibili

## Nooch

### Piero Lissoni • 2023

Inspiration • 5



rectangular and trapezoidal shapes. The latter creates gentle curves, becoming the key to varying the linearity of the composition of the elements, creating dynamic solutions.

The paddings are designed with sustainability in mind. They use regenerated materials, which are completely separable, and consist of two layers of polyurethane with different densities and firmness. The bottom layer of the seat cushion is made of polyurethane recycled from production waste, while the top layer is made of virgin bio-polyurethane.

in forma quadrata, rettangolare e trapezoidale. Quest'ultima diventa la chiave per variare la linearità della composizione degli elementi dando vita a soluzioni dinamiche.

Anche le imbottiture sono progettate all'insegna della sostenibilità. Utilizzano materiali rigenerati, completamente separabili, e si compongono di due strati di poliuretano a differenti densità e portanza. Lo strato inferiore del cuscino di seduta è in poliuretano riciclato da scarti di produzione, mentre lo strato superiore è realizzato in bio-poliuretano vergine.

The collection is enriched by a low table, with a square or rectangular base and a top in serpentine stone or enameled lava stone in clay, sage and ocean blue colors. To emphasize the linearity of the object, the frame is encased by tubular aluminum elements along its entire length, featuring semi-gloss varnish in the same colors as the seats.

A completare la collezione un tavolo basso, a base quadrata o rettangolare, con piano in pietra serpentino o pietra lavica smaltata nei colori argilla, salvia e blu oceano. Per sottolineare la linearità dell'oggetto, la struttura è avvolta in tutta la sua lunghezza da elementi tubolari in alluminio con verniciatura semilucida negli stessi colori delle sedute.

## Nooch

Piero Lissoni • 2023

Inspiration • 5



The tubular frame design has no interruption but has been wisely bent on the corners and features a cross design in the back to better host the back cushions. This technical detail will be adding to the seamless metal frame to become one of the distinctive features of the collection, together with the slats inherited from the Borea collection. Nooch stands out for the originality of the colors of its metal structure that go beyond trends and tastes, proposing unusual but inspiring tones such as forest green, avio blue, veronese red and graphite.

La struttura tubolare non ha interruzioni, ma è stata sapientemente piegata negli angoli e presenta un caratteristico motivo a X nella parte dello schienale per contenere la cuscineria. Questo dettaglio tecnico permette alla struttura in metallo di diventare uno degli elementi distintivi della collezione, insieme alle doghe ereditate dalla collezione Borea. Nooch si distingue per l'originalità dei colori della struttura metallica, proponendo degli insoliti e interessanti toni quali il verde foresta, il blu aviazione, il rosso veronese e il grafite.

# Nooch

## Piero Lissoni • 2023

Inspiration • 5

### Central elements

Elementi centrali

NH95C

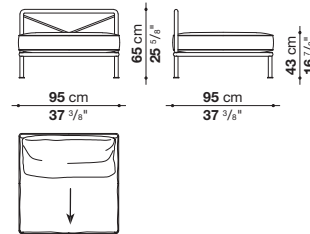

NH136C

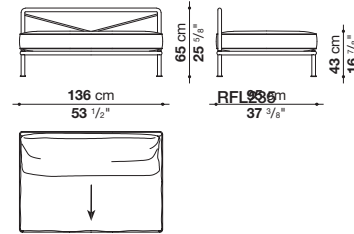

### Armchair

Poltrona

NH95

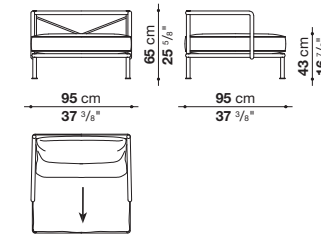

### Chaise longue

Chaise longue

NH136L

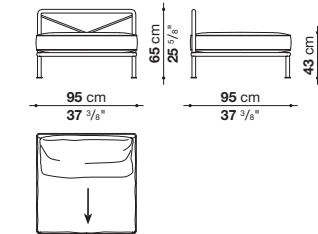

\* NH136LD

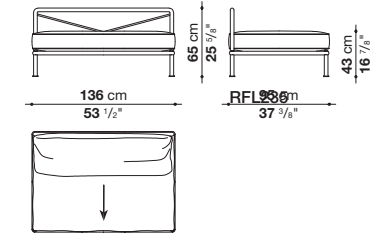

### Terminal elements

Elementi terminali

\* NH95TD

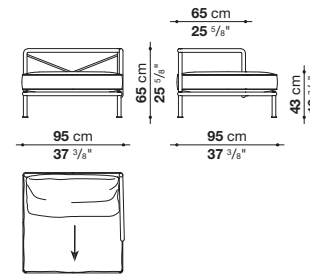

\* NH136TD

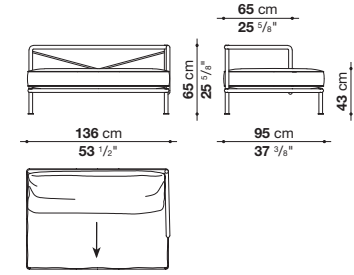

### Ottomans

Pouf

NH95PQ

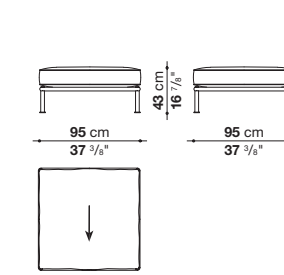

NH95P

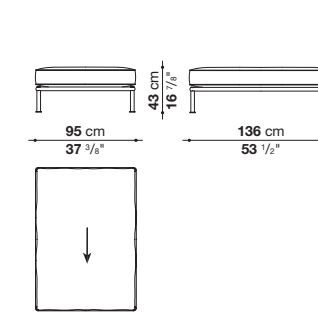

NH136P

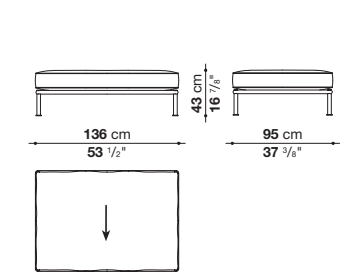

### Corner elements

Elementi angolari

NH95A

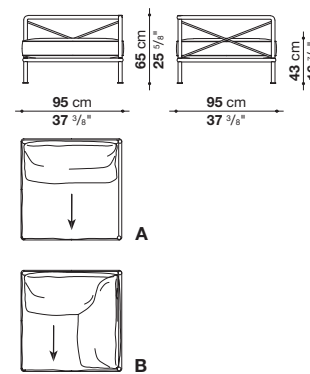

\* NH136AD

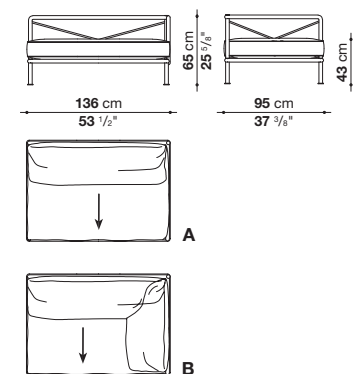

### Service elements

Elementi di servizio

TNH32 - TNH32\_L

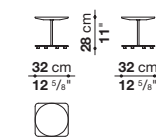

NH60\_SB

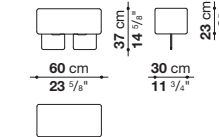

\* Elements available in right and left version. / Elementi disponibili nella versione destra e sinistra.

\* Elements available in right and left version. / Elementi disponibili nella versione destra e sinistra.



# Nooch

## Piero Lissoni • 2023

Inspiration • 5

### Top sections

Inserti piano

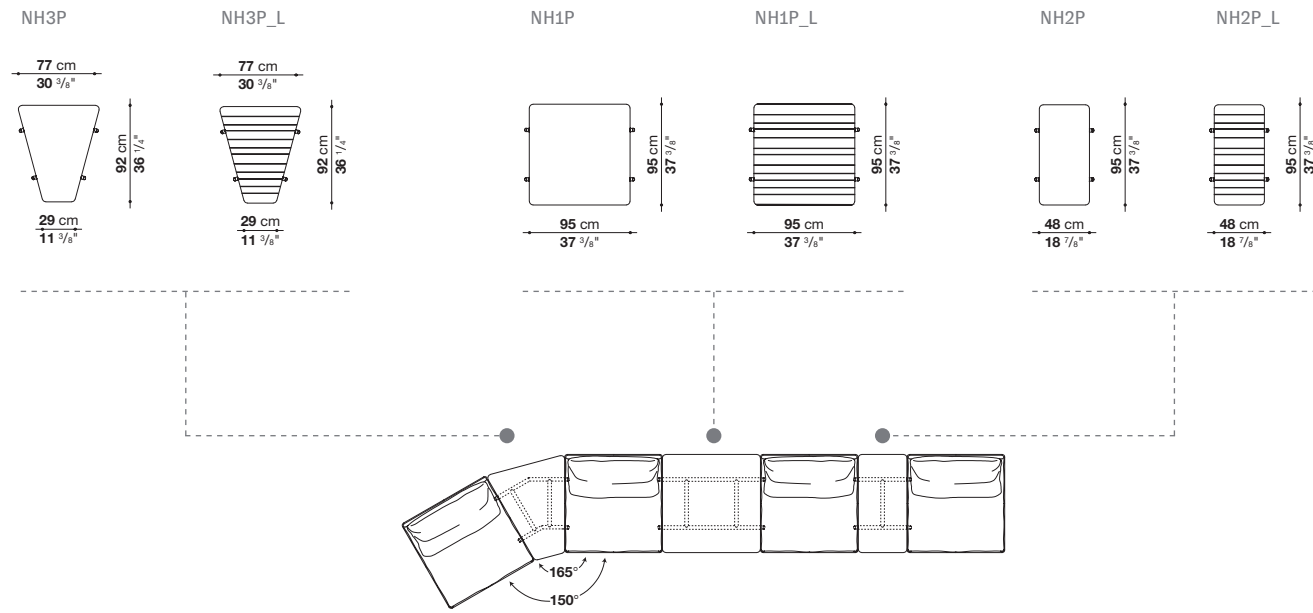

### Low table

Tavoli bassi

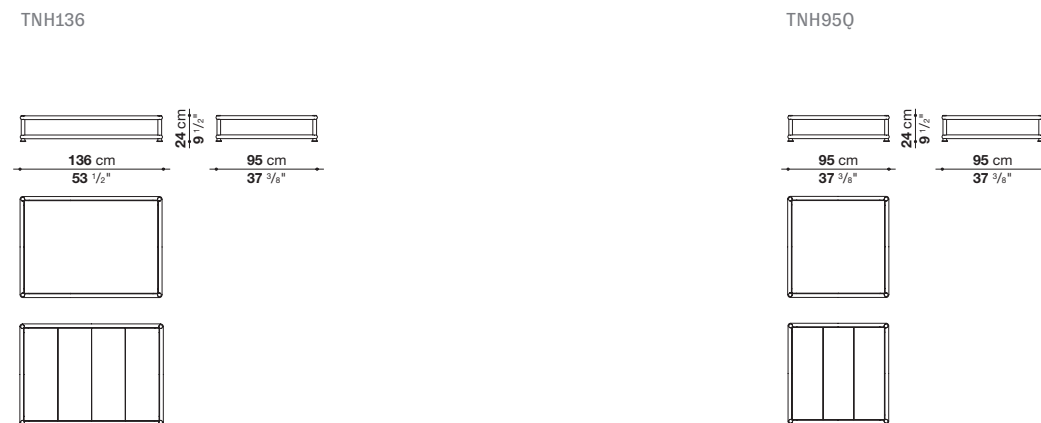

### Product items/Prodotti

Recommended combinations/Abbinamenti suggeriti



2821425 Lamone	2820411 Lilia	2820100 Lilia	0452V forest green semi-glossy painted verniciato semilucido verde selva



2821895 Lamone	2820811 Lilia	2620800 Aliseo	0860B avio blue semi-glossy painted verniciato semilucido blu avio	0408S Serpentine stone pietra Serpentino



2821425 Lamone	2820411 Lilia	2819435 Lola	0452V forest green semi-glossy painted verniciato semilucido verde selva	0456T natural teakwood teak naturale



2821275 Lamone	2820411 Lilia	0761R veronese red semi-glossy painted verniciato semilucido rosso veronese	0456T natural teakwood teak naturale



2821425 Lamone	2820100 Lilia	0452V forest green semi-glossy painted verniciato semilucido verde selva



2620800 Aliseo	2821895 Lamone	0860B avio blue semi-glossy painted verniciato semilucido blu avio

The colours and materials shown are an indication. Images not in scale.  
La tonalità dei colori e dei materiali è indicativa. Immagini non in scala.

# Nooch

## Piero Lissoni • 2022

Inspiration • 5

Frame	die-cast and extruded aluminium
Back and seat upholstery	shaped polyurethane, biodegradable polyester fibre recycled from PET, cover in water repellent polyester fibre
Cushion upholstery	biodegradable polyester fibre recycled from PET, cover in water repellent polyester fibre
Armrest support NH60_5B	shaped polyurethane, cover in water repellent polyester fibre
Top section	Serpentine stone or solid teakwood
Spacers	plastic material
Ferrules	thermoplastic elastomer
Waterproof cover cloth	PES fabric coated on one side in PU
Cover	fabric in limited categories

Small tables	
Frame	die-cast and extruded aluminium
Top	Serpentine stone or enamelled lava stone
Tip and spacers	thermoplastic elastomer

Struttura	pressofusione ed estrusi di alluminio
Imbottitura sedile e schienale	poliuretano sagomato, fibra di poliestere biodegradabile riciclata da PET, fodera in fibra di poliestere con trattamento idrorepellente
Imbottitura cuscino NH60_60C	fibra di poliestere biodegradabile riciclata da PET, fodera in fibra di poliestere con trattamento idrorepellente
Supporto bracciolo NH60_5B	poliuretano sagomato, fodera in fibra di poliestere con trattamento idrorepellente
Inserto piano	pietra Serpentino o legno massello di teak
Distanziali	materiale plastico
Puntali	elastomero termoplastico
Telo di copertura impermeabile	tessuto PES monospalmato su un lato PU
Rivestimento	tessuto in categorie limitate

Tavolini	
Struttura	pressofusione ed estrusi di alluminio
Piano	pietra Serpentino o pietra lavica smaltata
Puntali e distanziali	elastometro termoplastico

### Modular elements and armchair frame

Elementi componibili e struttura poltrona

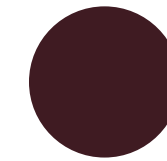

**0761R**  
veronese red  
semi-glossy painted  
verniciato semilucido  
rosso veronese

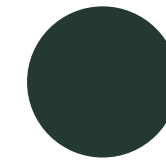

**0452V**  
forest green  
semi-glossy painted  
verniciato semilucido  
verde selva

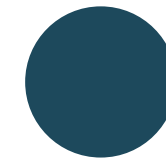

**0860B**  
avio blue  
semi-glossy painted  
verniciato semilucido  
blu avio

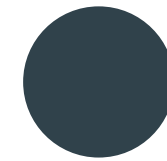

**0319G**  
graphite  
semi-glossy painted  
verniciato semilucido  
grafite

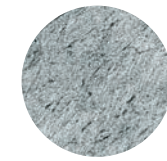

**0408S**  
Serpentine stone  
pietra Serpentino



**0456T**  
natural teakwood  
teak naturale

### Top sections and service element top

Inserto e piano elemeti di servizio

### Small table combinations

Combinazione di tavolini

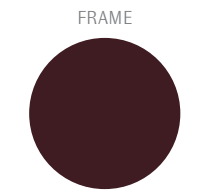

**0761R**  
veronese red  
semi-glossy painted  
verniciato semilucido  
rosso veronese

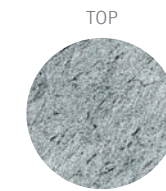

**0408S**  
Serpentine stone  
pietra Serpentino

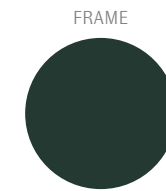

**0452V**  
forest green  
semi-glossy painted  
verniciato semilucido  
verde selva

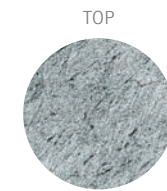

**0408S**  
Serpentine stone  
pietra Serpentino

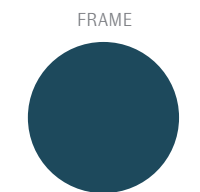

**0860B**  
avio blue  
semi-glossy painted  
verniciato semilucido  
blu avio



**0408S**  
Serpentine stone  
pietra Serpentino

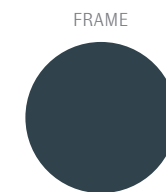

**0319G**  
graphite  
semi-glossy painted  
verniciato semilucido  
grafite

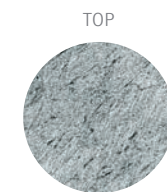

**0408S**  
Serpentine stone  
pietra Serpentino

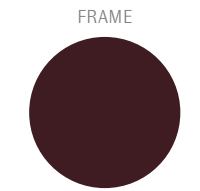

**0761R**  
veronese red  
semi-glossy painted  
verniciato semilucido  
rosso veronese

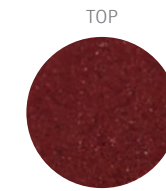

**0032A**  
clay enamelled lava stone  
pietra lavica smaltata  
argilla

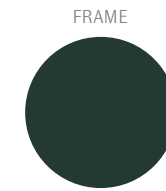

**0452V**  
forest green  
semi-glossy painted  
verniciato semilucido  
verde selva

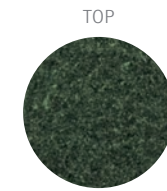

**0057S**  
sage enamelled lava stone  
pietra lavica smaltata  
salvia

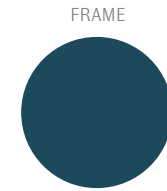

**0860B**  
avio blue  
semi-glossy painted  
verniciato semilucido  
blu avio

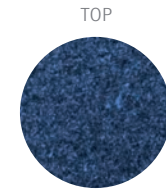

**0097B**  
ocean blue enamelled  
lava stone  
pietra lavica smaltata  
blu oceano

The colours and materials shown are an indication. Images not in scale.  
La tonalità dei colori e dei materiali è indicativa. Immagini non in scala.

## Oh, it rains!

### Philippe Starck · 2020

Inspiration • 129



The collaboration between B&B Italia and Philippe Starck leads to the birth of a sofa and an armchair, both with impressive dimensions and highly scenographic presence, that surprisingly combine an unusual shape and an unexpected function, with a name that really attracts attention. The designer started his research for this project by going back to the origins of outdoor furniture, that of nomads and soldiers: desert tents and field equipment, colonial colors and very light materials, essential shapes with function connected with rapid action. Colours and materials go hand in hand with the initial concept and the collection introduces colonial shades waterproof fabrics. The collection is enhanced by optional cushions that guarantee extra comfort and a dynamic look to this large object, suitable for private settings and also for outdoor areas in hotels and lounge. From a technical standpoint, the backrest is made with a double layer of water-repellent fabric, which makes it 100% waterproof. It is also possible to choose the version with a side table integrated into the structure, available in Mediterranean stone.

Nata dalla collaborazione tra B&B Italia e Philippe Starck, la collezione Oh, it rains! propone un divano e una poltrona studiati per essere utilizzati all'aperto con un design elegante, frutto di una funzionalità iconoclasta, che si adatta alla perfezione a qualsiasi ambiente pubblico o privato che sia.

Il designer si è ispirato alle origini del concetto di outdoor e di arredamento per esterni: tende del deserto e attrezzature da campo tipiche dei popoli nomadi e dei soldati, colori coloniali e materiali molto leggeri, forme essenziali dalle funzionalità intuitive e di facile implementazione. I colori e i materiali utilizzati sfoggiano una tavolozza di tonalità che vanno dal beige al marrone caldo. I tessuti sono idrorepellenti e rendono il prodotto completamente impermeabile.

La collezione è arricchita da numerosi cuscini opzionali che garantiscono ancora più comfort e dinamicità a questo prodotto adatto sia ad ambienti privati che ad aree outdoor di hotel e lounge. Infine, nella struttura della seduta, è possibile integrare un tavolino in pietra mediterranea.

#### Sofa

##### Divano

OH280

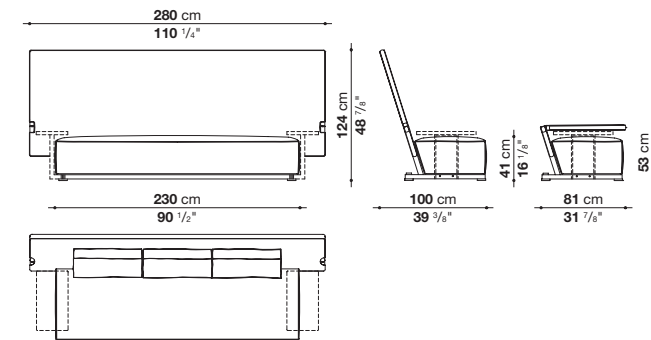

#### Armchair

##### Poltrona

OH140PS - OH140PD

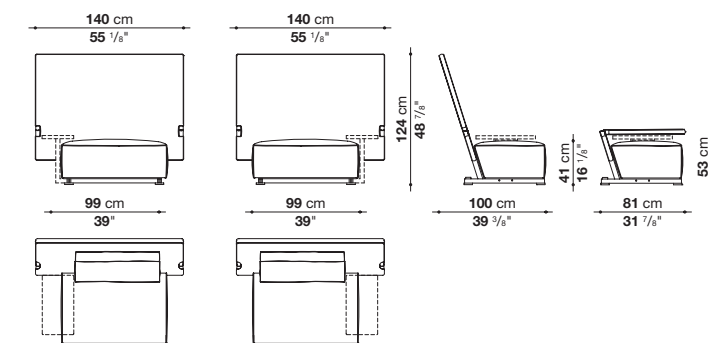

#### Small table

##### Tavolino

TOH1

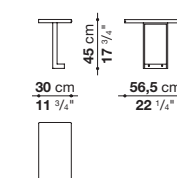

## Oh, it rains!

### Philippe Starck · 2020

Inspiration • 129

The large backrest of the product it is not just decorative but it acts like a wall or a partition to create an intimate and private setting. When necessary, it folds down on top of the seat so cushions and seat are covered and protected.

L'ampio schienale non è solo decorativo ma crea in maniera del tutto naturale uno spazio intimo e privato che grazie alla impeccabile ergonomia si reclinata facilmente sulla seduta, in caso di pioggia o maltempo, in modo che cuscini e seduta siano coperti e protetti.



Frame	aluminium
Upholstery	shaped polyurethane, cover in water repellent polyester fibre
Small table (TOH1)	Mediterranean stone
Ferrules	plastic material
Waterproof cover cloth	PES fabric coated on one side in PU
Cover	fabric in limited categories

Struttura	alluminio
Imbottitura	poliuretano sagomato, fodera in fibra di poliestere con trattamento idrorepellente
Piano tavolino (TOH1)	pietra Mediterranea
Puntali	materiale plastico
Telo di copertura impermeabile	tessuto PES monospalmato su un lato PU
Rivestimento	tessuto in categorie limitate

Frame  
Struttura



0722T  
titanium  
titanio

Feet  
Piedini

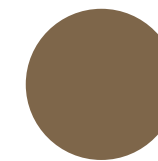

0521B  
bronze  
bronzo

Hinge  
Cerniera

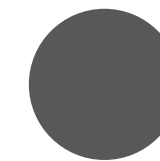

0031A  
warm grey anodized  
anodizzato warm grey

Small table top (TOH1)  
Piano tavolino

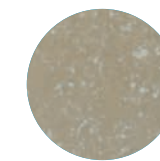

0463P  
Mediterranean stone  
pietra Mediterranea

The colours and materials shown are an indication. Images not in scale.  
La tonalità dei colori e dei materiali è indicativa. Immagini non in scala.

## Overscale Flames Outdoor

### Jean-Marie Massaud • 2008

Inspiration • 316



The large oil candles designed by Jean-Marie Massaud are in high density polyurethane resin (Baydur®), with a metallic frame painted matt white.

Le grandi candele a olio disegnate da Jean-Marie Massaud sono in resina poliuretanicà ad alta densità (Baydur®), con struttura metallica verniciata bianca opaca.

Frame	metal profiles
Shell	high density polyurethane resin (Baydur®)
Nozzles	anodized aluminium

Struttura	profili metallici
Corpo	resina poliuretanicà ad alta densità (Baydur®)
Ugelli	alluminio anodizzato

#### Candles

#### Candele

AB20043B

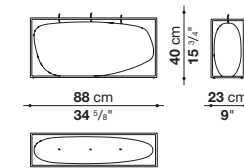

AB20044B

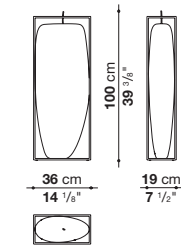

#### Frame and shell

#### Struttura e corpo

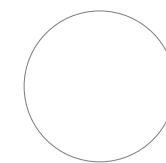

white  
bianco

The colour and material shown are an indication. Image not in scale.  
La tonalità del colore e del materiale è indicativa. Immagine non in scala.

## Pablo Outdoor

### Vincent Van Duysen • 2022

Inspiration • 63



The Pablo collection by Vincent Van Duysen, with its decisive design, rigorous strict lines and innovative proportions, breathing life to a series that includes a sofa, an armchair in two depths, a footrest and two coffee tables.

La collezione Pablo di Vincent Van Duysen, con il suo design deciso, le linee rigorose e le sue proporzioni innovative, dà vita a una serie che comprende un divano, una poltrona in due profondità, un poggiatesta e due tavolini.

The soul of the original project lies in the wood frame, which for Pablo Outdoor is made of teak, the ideal material for outdoors. The geometry of the supporting frame presents a sophisticated balance of straight and curved lines, but this is not just an aesthetic choice. In fact, the frame, with its uninterrupted surface, was designed to ease maintenance of the wood, which is easy to treat as necessary. The continuity of the form and quality of the wood make Pablo Outdoor particularly pleasant to the touch.

L'anima del progetto originario si ritrova nella struttura in legno, che per Pablo Outdoor diventa teak, materiale ideale per l'outdoor. La geometria della struttura portante presenta sofisticati equilibri di linee rette e curve, ma non si tratta soltanto di una scelta estetica. Infatti, la struttura dalla superficie ininterrotta è stata ideata in modo da favorire la manutenzione del legno, agevole da trattare all'occorrenza. La continuità della forma e la qualità del legno rendono Pablo Outdoor particolarmente piacevole al tatto.

## Pablo Outdoor

### Vincent Van Duysen • 2022

Inspiration • 63



For the sofa, comfort and softness are found in the deep seat and back enhanced with cushions that can be arranged freely. The low seat is composed of a single generously upholstered cushion, nearly a mattress that creates an ample area perfect for isolating yourself or sharing moments of conviviality.

Nel divano, comodità e morbidezza derivano dalla seduta profonda e dallo schienale arricchito da cuscini a disposizione libera. La seduta ribassata è formata da un unico cuscino dalla generosa imbottitura, quasi un materasso che crea una dimensione ampia, perfetta per isolarsi o per condividere occasioni conviviali.



The rear fabric panels are anchored to rods that can be removed easily. This is also an aesthetic choice that meets a technical solution aimed at simplifying care for the wood and maintenance of the textile parts. These design expedients allow customers choosing the Pablo Outdoor collection to let it age naturally or have it returned its original condition.

I pannelli posteriori in tessuto si ancorano a bacchette facilmente rimovibili: anche in questo caso una scelta estetica che incontra una soluzione tecnica mirata a semplificare la cura del legno e la manutenzione delle parti tessili. Si tratta di accorgimenti progettuali che consentono a chi sceglie la collezione Pablo Outdoor di lasciarla invecchiare naturalmente, oppure di farla tornare rapidamente alla condizione d'origine.

## Pablo Outdoor

### Vincent Van Duysen • 2022

Inspiration • 63



The sofa interacts also with the armchair available in two depths, one more suited to conversation, the other for relaxing as if on a chaise longue.

Il divano dialoga inoltre con la poltrona in due varianti di profondità, una più adatta alla conversazione, l'altra a un relax da chaise longue.

The footrest has a similar teak frame and an upholstered seat covered in fabric. Solid and compact, this accessory is also suitable for use as a service small table.

Il poggiatesta presenta un'analogia struttura in teak e una seduta imbottita rivestita in tessuto. Solido e compatto, questo accessorio diventa adatto anche per l'utilizzo come tavolino di servizio.



## Pablo Outdoor

### Vincent Van Duysen • 2022

Inspiration • 63



With Pablo Outdoor collection, planning complete and cosy relaxing areas is easy thanks to an additional wooden small element that with the optional cushion can transform itself from a coffee table into a comfy ottoman.

Con la collezione Pablo Outdoor, progettare zone relax complete e accoglienti è facile grazie ad un piccolo elemento aggiuntivo in legno che con il cuscino opzionale può trasformarsi da tavolino in un comodo pouf.



The decisive yet soft lines of Pablo Outdoor seats are perfectly balanced in the small cement outdoor tables. Linear, solid, and highly geometric shapes represent the heart of these architectural objects with a certain effect. To provide multiple solutions, these small tables come in two sizes and two colours. The antique white and greige colours give shape to a large, low model that works perfectly as an island defining a conversation area, and a higher, narrower model with a square base, is ideal as a service element next to the sofa or armchair.

Le linee decise e tuttavia morbide delle sedute Pablo Outdoor trovano il perfetto contraltare nei tavolini da esterni in cemento. Forme lineari, solide, ad alto tasso di geometria, rappresentano il cuore di questi oggetti architettonici dal sicuro impatto. Per fornire molteplici soluzioni, questi tavolini nascono in due misure e due colori. Le tinte bianco antico e greige danno forma a un modello ampio e basso, perfetto come isola che definisce un'area conversazione, e a un modello più alto e slanciato, a base quadrata, ideale come elemento di servizio accanto al divano o alla poltrona.

## Pablo Outdoor

### Vincent Van Duysen • 2022

Inspiration • 63



The rear panel of Pablo Outdoor wooden structures is available in natural, clay, sea blue and moss green coloured cloth. This fabric rear panel is anchored to rods that can be removed in order to ease washing and maintenance of the product.

Il pannello posteriore delle strutture in legno Pablo Outdoor è disponibile in tela nei colori naturale, argilla, blu mare e verde muschio. Questo pannello posteriore in tessuto è ancorato ad aste che possono essere rimosse per facilitare il lavaggio e la manutenzione del prodotto.



This is also an aesthetic choice that meets a technical solution aimed at simplifying care for the wood and maintenance of the textile parts. These design expedients allow customers choosing the Pablo Outdoor collection to let it age naturally or have it returned its original condition.

Questa è anche una scelta estetica che incontra una soluzione tecnica volta a semplificare la cura del legno e la manutenzione delle parti tessili. Questi accorgimenti progettuali consentono ai clienti che scelgono la collezione Pablo Outdoor di farla invecchiare naturalmente o di riportarla alle condizioni originali.

## Pablo Outdoor

### Vincent Van Duysen • 2022

Inspiration • 63

## Sustainability



The padding of Pablo Outdoor are also displaying another eco-friendly material as the 100% recycled polyester fibres from PET, which convey richness and generous comfort to the cushions.

Le imbottiture di Pablo Outdoor sfoggiano anche un altro materiale ecologico come le fibre di poliestere riciclate al 100% da PET, che donano ricchezza e generoso comfort ai cuscini.

Natural teakwood structures with no metal joints and plastic seat slats underline the sustainability of this collection. Exposure to sunlight and rain will finely age the genuine wood used and the provided B&B Italia maintenance kit helps in maintaining its original sheen.

Strutture in legno di teak naturale senza giunzioni metalliche e doghe di seduta in plastica sottolineano la sostenibilità di questa collezione. L'esposizione alla luce solare e alla pioggia invecchierà il vero legno utilizzato e il kit di manutenzione B&B Italia in dotazione aiuta a mantenere la sua lucentezza originale.

## Pablo Outdoor

### Vincent Van Duysen • 2022

Inspiration • 63

Sofa  
Divano

PBL210

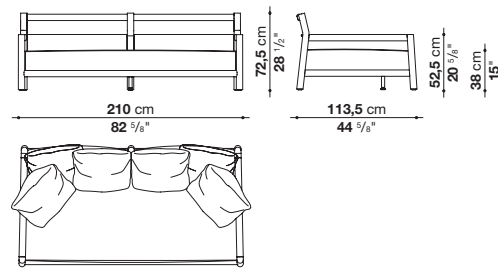

Ottoman\*  
Pouf\*

PBL75P

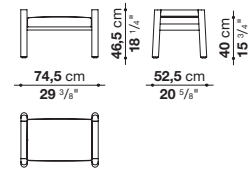

Armchairs  
Poltrone

PBL82L

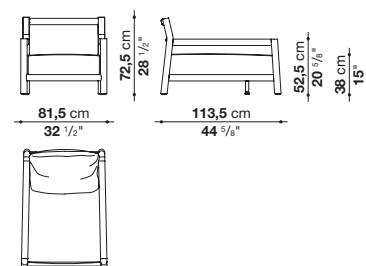

PBL80

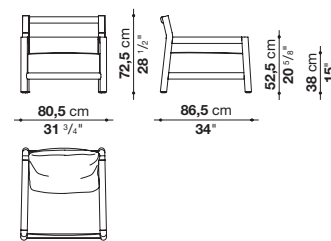

Small tables  
Tavolini

TPB130

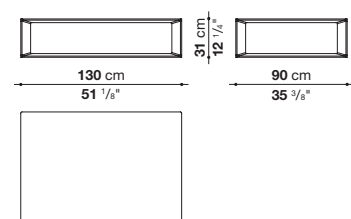

TPB55

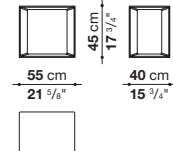

\*Not ordering the seat cushion, the ottoman can be used as small table.  
\*Non ordinando il cuscino sedile, il pouf può essere utilizzato come tavolino.

Frame	solid wood
Upholstery	shaped polyurethane of different density, cover in water repellent polyester fibre
Back support	stainless steel tubular covered in fabric
Seat slats	polypropylene reinforced with glass fibre
Top and frame (TPB55 - TPB130)	cement (Ultra Light Performance Concrete)
Ferrules	thermoplastic material
Waterproof cover cloth	PES fabric coated on one side in PU
Cover	fabric in limited categories

Struttura	legno massello
Imbottitura	poliuretano sagomato a densità differenziata, fodera in fibra di poliestere con trattamento idrorepellente
Supporto schienale	tubolari in acciaio inox rivestiti in tessuto
Doghe seduta	polipropilene rinforzato con fibra di vetro
Piano e struttura (TPB55 - TPB130)	cemento (Ultra Light Performance Concrete)
Puntali	materiale termoplastico
Telo di copertura impermeabile	tessuto PES monospalmato su un lato PU
Rivestimento	tessuto in categorie limitate

Frame  
Struttura



0456T  
natural teakwood  
teak naturale

Top and frame (TPB130 - TPB55)  
Piano e struttura



0270B  
antique white cement  
cemento bianco antico

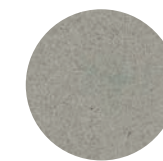

0240G  
greige cement  
cemento greige

Back support  
Supporto schienale

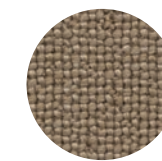

2572102  
natural Laguna  
Laguna naturale

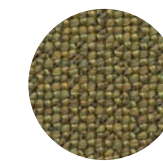

2822401  
moss green Lamar  
Lamar verde muschio

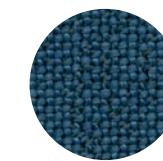

2822890  
Sea blue Lamar  
Lamar blu mare

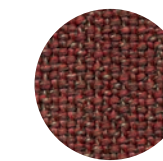

2822760  
Lamar argilla  
clay Lamar

The colours and materials shown are an indication. Images not in scale.  
La tonalità dei colori e dei materiali è indicativa. Immagini non in scala.

## Papilio Shell Outdoor

Naoto Fukasawa • 2016

Inspiration • 292



Papilio Shell Outdoor is linked through its name to the previous family of very successful chairs and armchairs, but has an independent history. Originating from a shell with a design that enhance comfort, it expresses considerable versatility that makes it perfect in different situations.

Papilio Shell Outdoor cita con il suo nome una precedente famiglia di sedute di grande successo, ma ha una storia indipendente. Originata da una scocca, il cui disegno sottolinea l'accoglienza e la comodità, esprime una notevole versatilità che la rende utilizzabile in situazioni molto diverse tra loro.

Shell	polypropylene
Support frame	stainless steel profiles
Ferrules	thermoplastic material

Scocca	polipropilene
Struttura di sostegno	profilati d'acciaio inossidabile
Puntali	materiale termoplastico

### Chair Sedia

OSH1

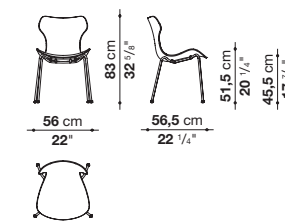

### Support frame Struttura di sostegno

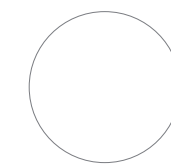

**09010**  
white painted  
verniciato bianco

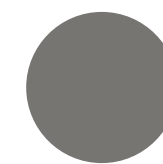

**0792T**  
greige painted  
verniciato greige

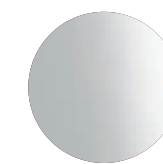

**0772C**  
stainless steel  
acciaio inox

### Shell Scocca

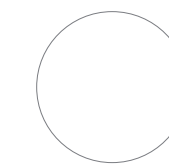

**0116B**  
white polypropylene  
polipropilene bianco

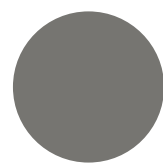

**0235G**  
greige polypropylene  
polipropilene greige

The colours and materials shown are an indication. Images not in scale.  
La tonalità dei colori e dei materiali è indicativa. Immagini non in scala.

**Piet**  
B&B Italia CR&S 2021  
Inspiration • 326

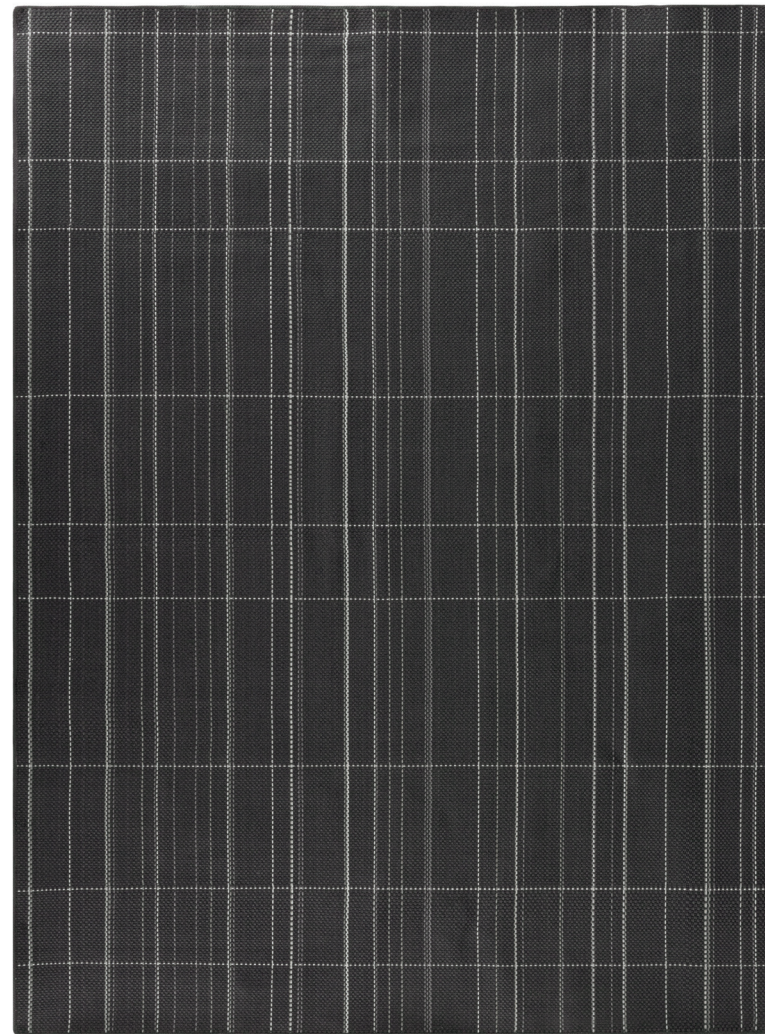

Composition	100% polypropylene	Composizione	100% polipropilene
-------------	--------------------	--------------	--------------------

**Carpets**  
Tappeti

TPI200

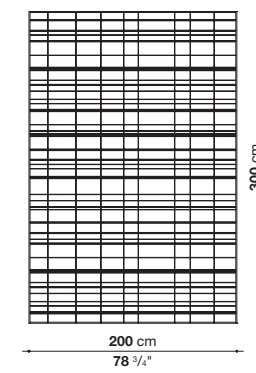

TPI250

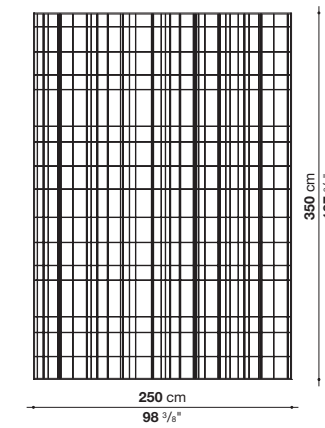

TPI300

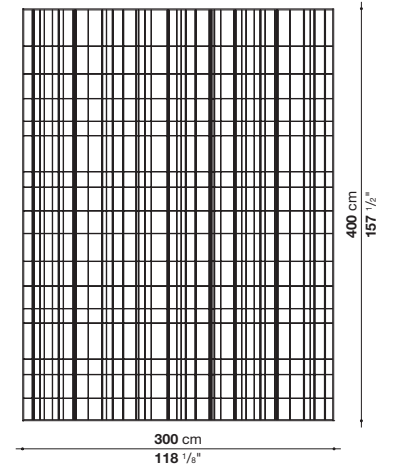

TPI300R

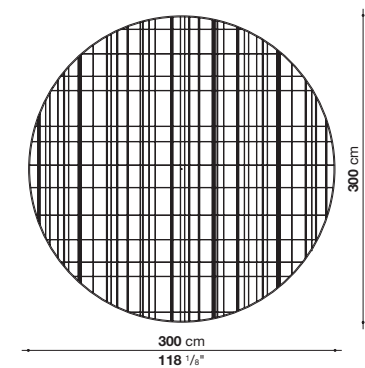

TPI250VL

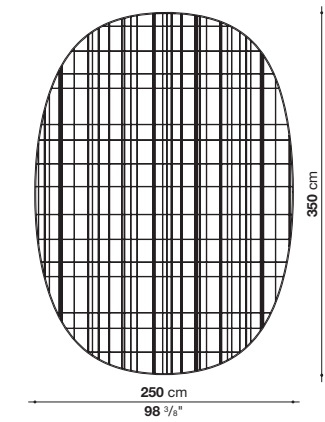

\*TPI01

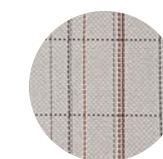
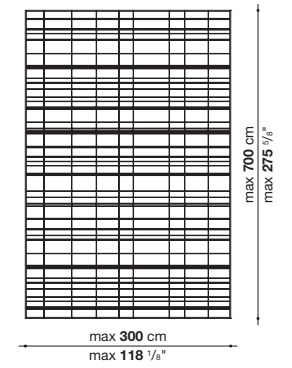

0072M  
multicolour  
multicolore



0037C  
rope  
corda



0046C  
anthracite  
antracite

The colours and materials shown are an indication. Images not in scale.  
\*Rectangular carpet per square meter. The minimum linear size in width realizable is 2,00 while the maximum size is 3,00 (for a total dimension up to 21 square meters).  
La tonalità dei colori e dei materiali è indicativa. Immagini non in scala. \*Tappeto rettangolare al metro quadrato. La dimensione minima lineare in larghezza realizzabile è 2,00 m mentre quella massima è 3,00 m (dimensione totale massima fino a 21 mq).

## Pushpam

### Naoto Fukasawa • 2018

Inspiration • 290



A collection of dining tables with small sizes and small tables that stand out for their perfect formal balance and for the striking texture of their cement finish, available in white or greige. "Many years ago, I called my chairs Papilio because their silhouettes reminded me of butterflies. Now I have called my latest project Pushpam (flower in Indonesian), because the Papilio Shell chairs sit around these tables like butterflies flying around a flower. The combination of a Pushpam table with the Papilio chairs creates a pleasant outdoor environment for a coffee or a quick meal. This was made possible by the use of a special cement moulding technology. We also added pigments so as to match the tables to the shell of the Papilio Shell chairs." (Naoto Fukasawa)

Una collezione di tavoli da pranzo di piccole dimensioni e di tavolini che si caratterizzano per il perfetto equilibrio formale e la forte matericità della finitura in cemento, in due varianti colore, greige e bianco. "Molti anni fa ho chiamato le mie sedie Papilio, perché la loro silhouette evocava le farfalle. Ora ho chiamato questo nuovo tavolo Pushpam (fiore in indonesiano), perché è un tavolo a cui le Papilio Shell stanno intorno come le farfalle volano intorno al Pushpam. Credo che questa introduzione di Pushpam insieme alle sedie Papilio crei un bell'ambiente outdoor per un caffè o un pasto veloce. Ciò è stato possibile grazie all'utilizzo di una tecnologia di stampo in cemento. Abbiamo aggiunto anche i pigmenti corretti per l'abbinamento con i colori delle scocche delle Papilio Shell." (Naoto Fukasawa)

Top and base-frame	cement (Ultra High Performance Concrete)	Piano e base	cemento (Ultra High Performance Concrete)
Coupling plate	galvanized sheet	Piastra di aggancio	lamiera zincata
Ferrules	thermoplastic material	Puntali	materiale termoplastico

#### Tables

Tavoli

TF85A

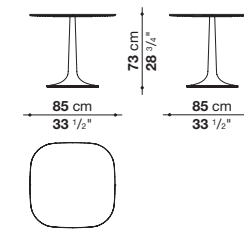

TF100RA

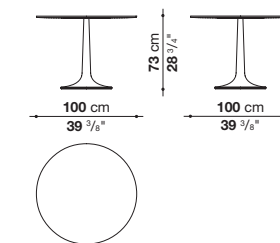

#### Small tables

Tavolini

TF85B

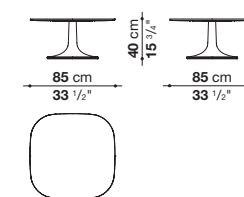

TF100RB

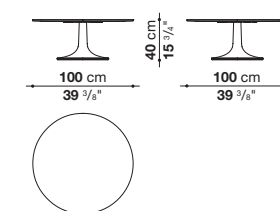

#### Top and base-frame

Piano e base

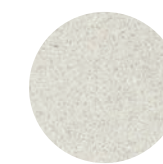

0159B  
white cement  
cemento bianco



0240G  
greige cement  
cemento greige

The colours and materials shown are an indication. Images not in scale.  
La tonalità dei colori e dei materiali è indicativa. Immagini non in scala.

## Ray Outdoor Fabric

Antonio Citterio • 2017

Inspiration • 200



Ray Outdoor Fabric features an interlacing ribbon pattern, created using polypropylene fibre that are resistant to UV rays and weathering. The range of colours, particularly suitable for outdoor environments, varies from turquoise to blue and from acid green to tortora through to bright bordeaux.

Ray Outdoor Fabric si distingue per l'intreccio a nastro, realizzato in fibra di polipropilene resistente ai raggi UV ed agli agenti atmosferici. La gamma di colori, particolarmente adatta agli ambienti outdoor, varia dal turchese al blu, dal verde acido al tortora sino ad un vivo colore bordeaux.

The "Fabric" collection consist of sofas available in two depths as well as modular elements such as terminal elements or chaise longue, armchair and a sunbed with wheels.

Le tipologie di seduta si compongono di divani in due profondità e di elementi componibili, dai terminali alle chaise longue, alla poltrona e al lettino con ruote.



## Ray Outdoor Fabric

### Antonio Citterio • 2017

Inspiration • 200

Sofas  
Divani

RF235

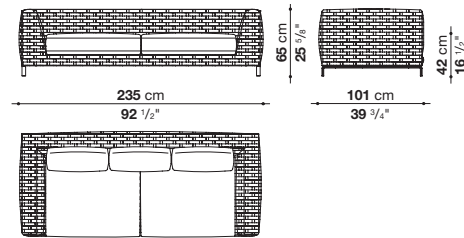

RFL235

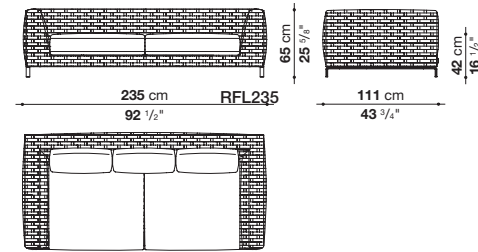

Armchair  
Poltrona

RF85

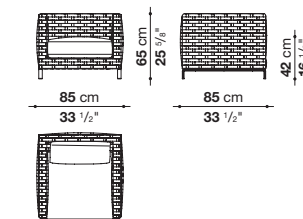

Terminal elements  
Elementi terminali

\* RF161D

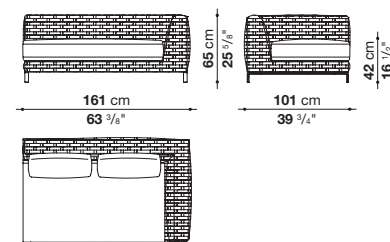

\* RF235D

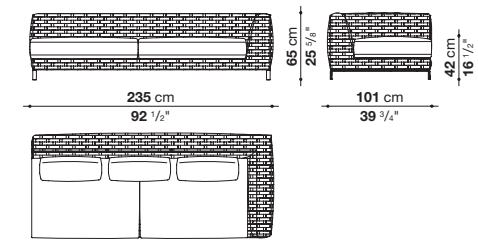

Sunbed with wheels and adjustable back  
Letto con ruote e schienale regolabile

RF203LA

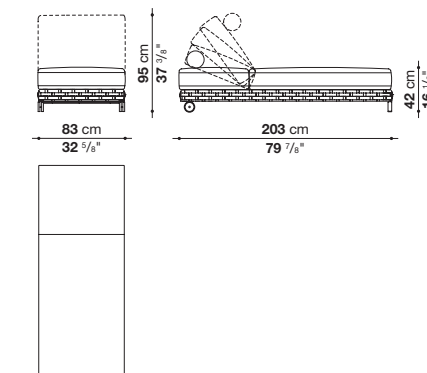

Chaise longue  
Chaise longue

\* RF161LD

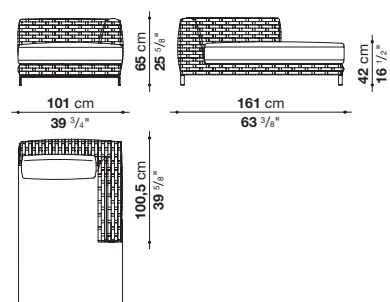

\* RF235LD

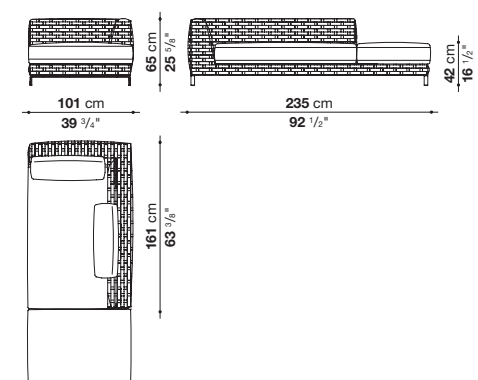

\* Elements available in right and left version. / Elementi disponibili nella versione destra e sinistra.

## Ray Outdoor Fabric

### Antonio Citterio • 2017

Inspiration • 200

Internal frame	tubular aluminium and aluminium profiles with polyester powder painting
Upholstery	shaped polyurethane, Solutex fibre and visco-elastic polyurethane combination, cover in water repellent polyester fibre
Back cushion	polyester fibre, cover in water repellent polyester fibre
Interlacing	polypropylene fibre braid
Headrest cushion (RF203LA)	shaped polyurethane, cover in water repellent polyester fibre
Seat top (RF203LA)	HPL stratified laminate panel
Mechanism (RF203LA)	aluminium extrusion
Wheels (RF203LA)	steel and thermoplastic material
Feet	die-cast aluminium and extrusions with polyester powder painting
Ferrules	thermoplastic material
Waterproof cover cloth	PES fabric coated on one side in PU
Cover	fabric in limited categories

Telaio interno	tubolari e profilati d'alluminio con verniciatura a polvere poliester
Imbottitura	poliuretano sagomato, combinazione fibra Solutex e poliuretano viscoelastico, fodera in fibra di poliester con trattamento idrorepellente
Cuscino schienale	fibra di poliester, fodera in fibra di poliester con trattamento idrorepellente
Intreccio	treccia in fibra di polipropilene
Cuscino poggiatesta (RF203LA)	poliuretano sagomato, fodera in fibra di poliester con trattamento idrorepellente
Piano sedile (RF203LA)	pannello in laminato stratificato HPL
Meccanismo (RF203LA)	estruso d'alluminio
Ruote (RF203LA)	acciaio e materiale termoplastico
Piedini	fusione ed estrusi d'alluminio con verniciatura a polvere poliester
Puntali	materiale termoplastico
Telo di copertura impermeabile	tessuto PES monospalmato su un lato PU
Rivestimento	tessuto in categorie limitate

#### Interlacing Intreccio



0787T  
turquoise polypropylene polipropilene turchese



0880B  
blue polypropylene polipropilene blu



0640V  
acid green polypropylene polipropilene verde acido



0577B  
bordeaux polypropylene polipropilene bordeaux



0428T  
tortora polypropylene polipropilene tortora

#### Feet Piedini

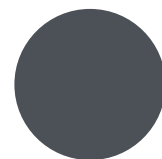

0236B  
anthracite painted verniciato antracite

#### Product items/Prodotti Recommended combinations/Abbinamenti suggeriti



2481820  
Lesia



2481101  
Lesia



2563810  
Agate



0787T  
turquoise polypropylene polipropilene turchese



2481255  
Lesia



2481407  
Lesia



0640V  
acid green polypropylene polipropilene verde acido



2481820  
Lesia



2481101  
Lesia



2563810  
Agate



0787T  
turquoise polypropylene polipropilene turchese



2481207  
Lesia



0577B  
bordeaux polypropylene polipropilene bordeaux



2569101  
Ermitage



0880B  
blue polypropylene polipropilene blu



2481207  
Lesia



0577B  
tortora polypropylene polipropilene tortora

## Ray Outdoor Natural

Antonio Citterio • 2017

Inspiration • 206



After its success indoors, the Ray seating system designed by Antonio Citterio now include two new outdoor versions, namely the “Natural” and “Fabric” collections of seats which stand out for their new interlacings and materials.

Dopo il successo in ambito indoor, il sistema di sedute Ray di Antonio Citterio si veste per l'outdoor con due famiglie di sedute, “Natural” e “Fabric” che si distinguono per differenti intrecci e materiali.

Ray Outdoor Natural features an interlacing rope pattern reminiscent of Manila hemp, in perfect harmony with nature, and is created with textilene, making it perfect for outdoor use.

La famiglia Ray Outdoor Natural è caratterizzata da un intreccio a “corda” che si rifà all'abaca naturale, in perfetta armonia con la natura, ed utilizza textilene perfettamente adatto agli ambienti esterni.

## Ray Outdoor Natural

Antonio Citterio • 2017

Inspiration • 206



Ray Outdoor Natural is available with an extruded aluminium feet or teakwood base. The "Natural" collection consists of sofas available in two depths as well as modular elements such as terminal elements, chaise longue and armchair.

Ray Outdoor Natural è disponibile sia con piedini in estruso d'alluminio che nella versione con basamento in teak. Le tipologie di seduta si compongono di divani in due profondità e di elementi componibili, dai terminali alle chaise longue e poltrona.

## Ray Outdoor Natural

### Antonio Citterio • 2017

Inspiration • 206

Sofas with metal feet  
Divani con piedini metallici

RN236

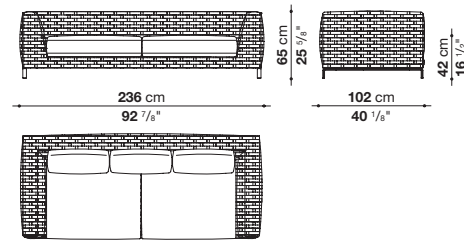

RNL236

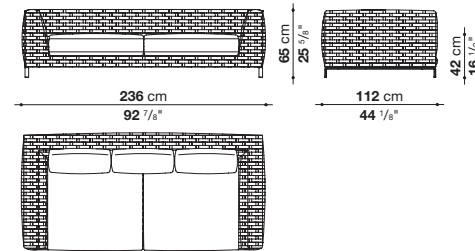

Sofas with wooden base  
Divani con base in legno

RN236\_B

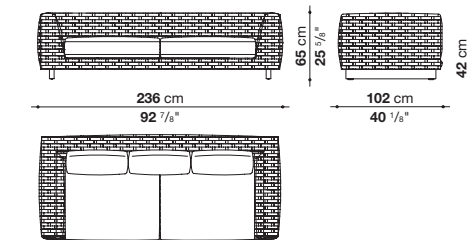

RNL236\_B

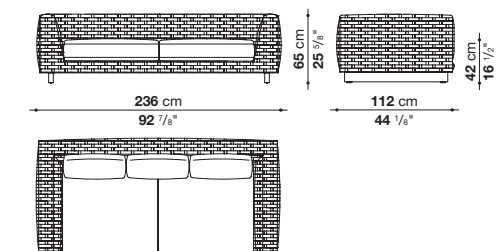

Terminal element with metal feet  
Elemento terminale con piedini metallici

\* RN236D

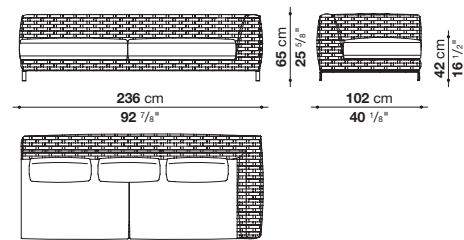

Chaise longue with metal feet  
Chaise longue con piedini metallici

\* RN236LD

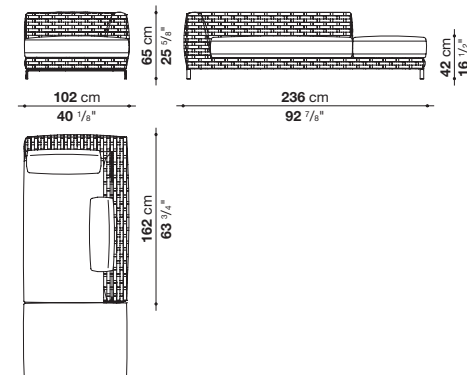

Terminal element with wooden base  
Elemento terminale con base in legno

\* RN236D\_B

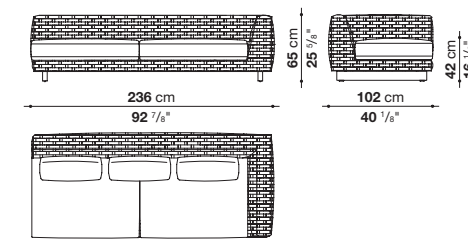

Chaise longue with wooden base  
Chaise longue con base in legno

\* RN236LD\_B

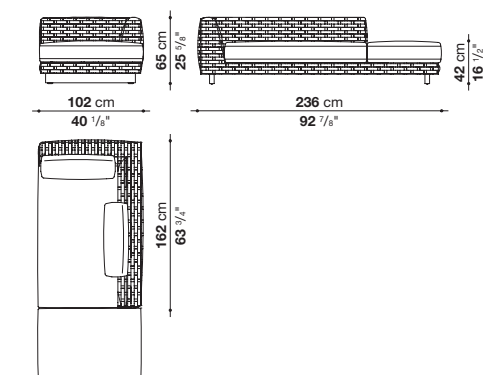

Armchair with metal feet  
Poltrona con piedini metallici

RN86

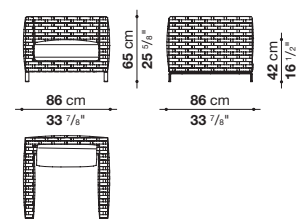

Armchair with wooden base  
Poltrona con base in legno

RN86\_B

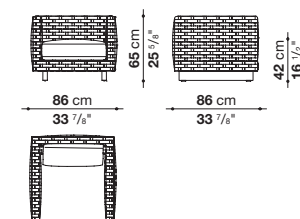

\* Elements available in right and left version. / Elementi disponibili nella versione destra e sinistra.

\* Elements available in right and left version. / Elementi disponibili nella versione destra e sinistra.

# Ray Outdoor Natural

## Antonio Citterio • 2017

Inspiration • 206

Internal frame	tubular aluminium and aluminium profiles with polyester powder painting
Upholstery	shaped polyurethane, Solotex fibre and visco-elastic polyurethane combination, cover in water repellent polyester fibre
Back cushion	polyester fibre, cover in water repellent polyester fibre
Interlacing	textilene braid
Feet	die-cast aluminium and extrusions with polyester powder painting
Base	solid wood
Ferrules	thermoplastic material
Waterproof cover cloth	PES fabric coated on one side in PU
Cover	fabric in limited categories

Telaio interno	tubolari e profilati d'alluminio con verniciatura a polvere poliestere
Imbottitura	poliuretano sagomato, combinazione fibra Solotex e poliuretano viscoelastico, fodera in fibra di poliestere con trattamento idrorepellente
Cuscino schienale	fibra di poliestere, fodera in fibra di poliestere con trattamento idrorepellente
Intreccio	treccia in textilene
Piedini	fusione ed estrusi d'alluminio con verniciatura a polvere poliestere
Base	legno massello
Puntali	materiale termoplastico
Telo di copertura impermeabile	tessuto PES monospalmato su un lato PU
Rivestimento	tessuto in categorie limitate

### Product items/Prodotti

#### Recommended combinations/Abbinamenti suggeriti



2481280 Lesia	2481207 Lesia	2563257 Agate	0236B anthracite painted verniciato antracite	0528N natural colour textilene textilene color naturale



2481305 Lesia	2563257 Agate	0236B anthracite painted verniciato antracite	0528N natural colour textilene textilene color naturale



2481280 Lesia	2481207 Lesia	2563257 Agate	0492T antique grey teakwood teak antique grey	0528N natural colour textilene textilene color naturale



2481305 Lesia	2563257 Agate	0492T antique grey teakwood teak antique grey	0528N natural colour textilene textilene color naturale

#### Interlacing Intreccio



0528N  
natural colour textilene  
textilene color naturale

#### Feet Piedini

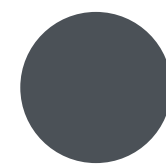

0236B  
anthracite painted verniciato antracite

#### Base Base

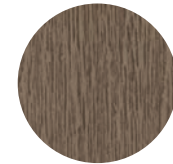

0492T  
antique grey teakwood teak antique grey



2481830 Lesia	0236B anthracite painted verniciato antracite	0528N natural colour textilene textilene color naturale



2481280 Lesia	2481207 Lesia	2563257 Agate	0236B anthracite painted verniciato antracite	0528N natural colour textilene textilene color naturale

The colours and materials shown are an indication. Images not in scale. La tonalità dei colori e dei materiali è indicativa. Immagini non in scala.

The colours and materials shown are an indication. Images not in scale. La tonalità dei colori e dei materiali è indicativa. Immagini non in scala.

## Ribes

Antonio Citterio • 2019

Inspiration • 141



Ribes is a modular seating system designed by Antonio Citterio with a focus on versatility, customisation, colour and research on materials. Sofas, central and end elements, chaises longues and ottomans all come in a huge variety of shapes and sizes that lend themselves to being arranged in an outdoor space according to personal taste thanks to the exceptional versatility of the modular components and the availability of a vast range of covers and finishes.

Ribes è un sistema di sedute componibili disegnato da Antonio Citterio, che mette al centro del progetto i temi della flessibilità, della personalizzazione, del colore e della ricerca sui materiali. Divani, elementi centrali e terminali, chaise longue e pouf, proposti in numerose tipologie e dimensioni, consentono di interpretare lo spazio outdoor in maniera molto personale grazie all'estrema flessibilità compositiva e alla possibilità di scegliere tra numerosissimi rivestimenti e finiture.

The starting point is a futon base with flexible glass-fibre slats resting on an aluminium frame to which two types of arm or back rest can be attached as desired: one with a polypropylene fibre interlacing, the other with a roller cushion.

Il punto di partenza è una base "futon" con doghe flessibili in fibra di vetro, appoggiate su una struttura in alluminio, sulla quale fissare liberamente braccioli e schienali previsti in due tipologie: a telaio con intreccio in fibra di polipropilene oppure a rullo.

## Ribes

### Antonio Citterio • 2019

Inspiration • 141



The seating system is enriched with seat cushions intended as comfortable mattresses to stretch out on and several shapes of back- and armrest cushion, all containing a new filling giving Ribes a particularly lived-in and soft look. Colour comes into play in the painted frames in shades of anthracite, sage and clay. These same tones are then picked up in the back and arm supports combining the colours sage and clay with a natural-coloured interlacing and anthracite to one in a matching shade, and the same for the brackets of the roller sections.

Il sistema di sedute si arricchisce di cuscini sedile pensati come comodi materassi dove rilassarsi e varie tipologie di cuscini schienale e bracciolo, tutti realizzati con una nuova imbottitura che dona a Ribes un aspetto vissuto particolarmente morbido. Il tema del colore viene introdotto dalle strutture verniciate nelle tonalità antracite, salvia e argilla. Queste nuance sono riprese dagli schienali e braccioli a telaio, che abbinano il salvia e l'argilla ad un intreccio naturale e l'antracite ad un intreccio tono su tono ed ai supporti delle versioni a rullo.

Because it is so versatile, Ribes can also be reconfigured over time by adding new elements as well as altering the functional use of existing ones. By substituting, adding or varying the position of the back and armrests, a sommier can turn into a vis-à-vis sofa, a sofa become an island and a corner seating plan transform into a comfortable bed. Ribes means transformation and is especially suited to those areas that are neither in-nor outside: verandas, shady patios, under a loggia or on a covered terrace allowing a fluid approach to the open spaces in the home.

Grazie alla flessibilità del sistema, Ribes può essere modificato nel tempo aggiungendo nuovi elementi, ma anche cambiando la funzione d'uso di quello esistenti. Sostituendo, aggiungendo o modificando la posizione di schienali e braccioli, un sommier può diventare un vis-à-vis, un divano può diventare un'isola, un angolare può diventare un comodo letto. Una natura trasformabile quella di Ribes, che si trova particolarmente a suo agio negli spazi di passaggio tra interno ed esterno, nelle verande o all'ombra di un patio, sotto un loggiato o un terrazzo coperto, per vivere con fluidità la casa e gli spazi aperti.



Ribes  
Antonio Citterio • 2019  
Inspiration • 141

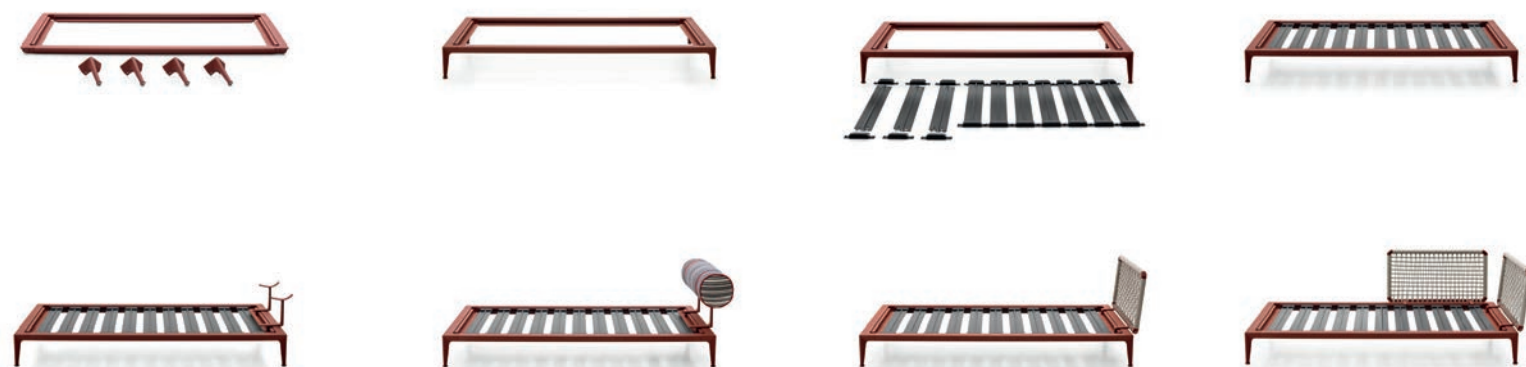

The Ribes sofa has several strengths including total disassembly, the possibility of storing the product for winter time, modularity and multiple configurations.

Il divano Ribes ha diversi punti di forza tra cui il totale disassemblaggio, la possibilità di essere stoccato per l'inverno, la componibilità e le molteplici configurazioni.

Sofas  
Divani

RB212

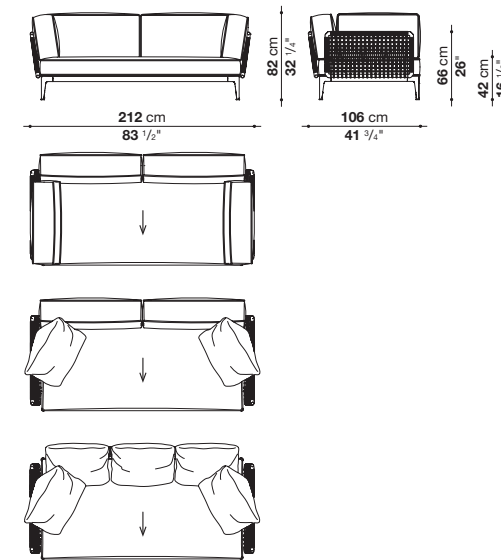

RBR220

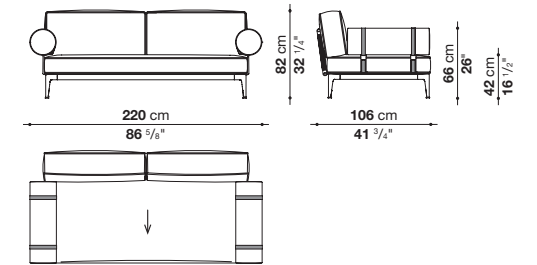

RB248

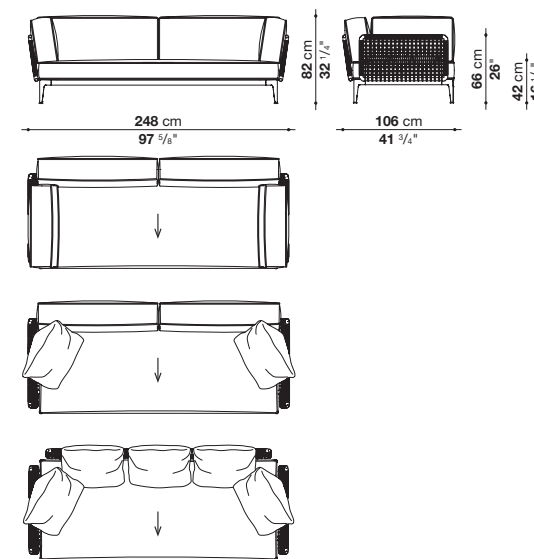

RBR256

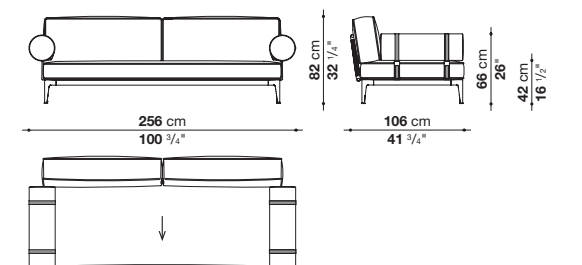

In the drawing the arrow shows the direction of the lines in case of cover with striped fabrics. Nel disegno la freccia indica la direzione delle righe in caso di rivestimento con tessuti rigati.

# Ribes

## Antonio Citterio • 2019

Inspiration • 141

### Central elements

Elementi centrali

RB190C

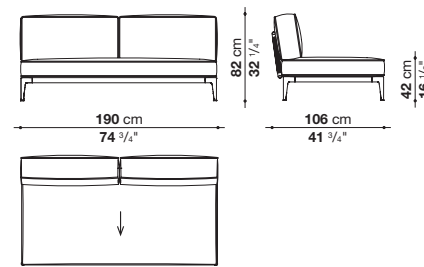

RBR190C

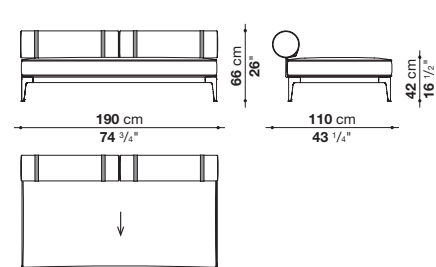

### Benches

Panche

RB190PA\_1

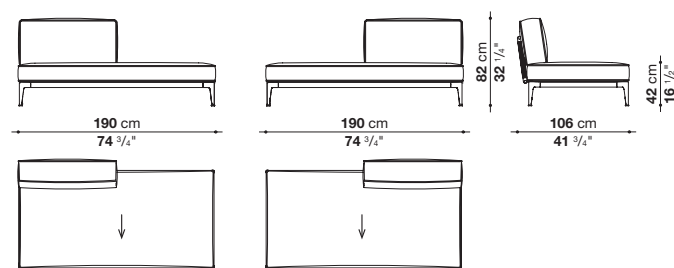

RB190PA

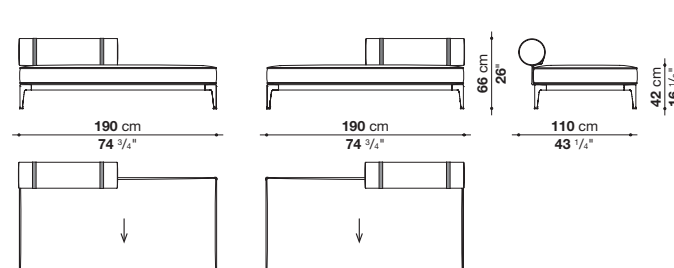

RB190PA\_2

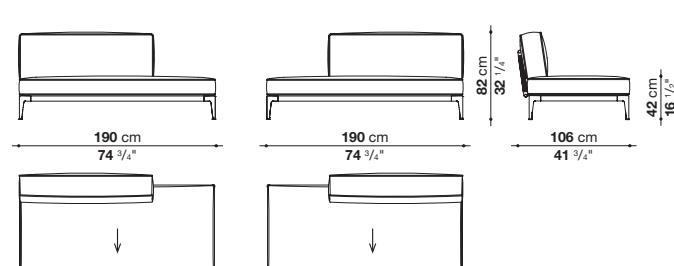

RB190PA\_3

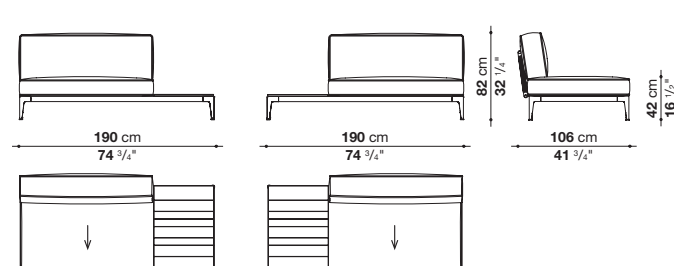

### Terminal elements

Elementi terminali

RB201T\_1

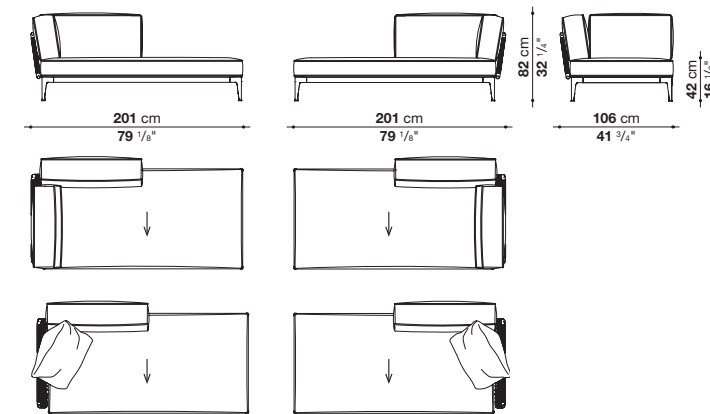

RBR205T\_1

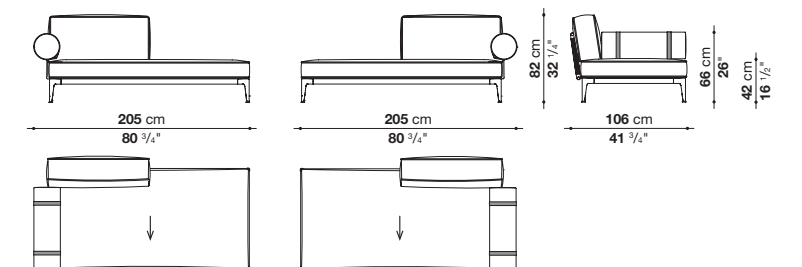

RB201T\_2

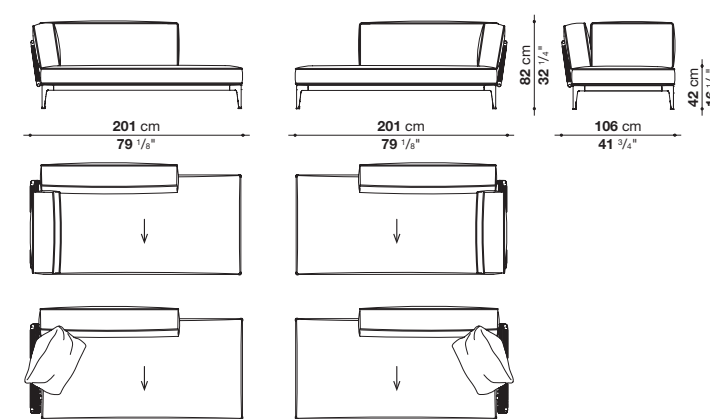

RBR205T\_2

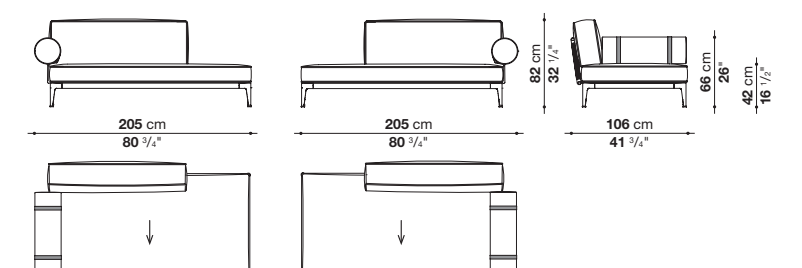

RB201T\_3

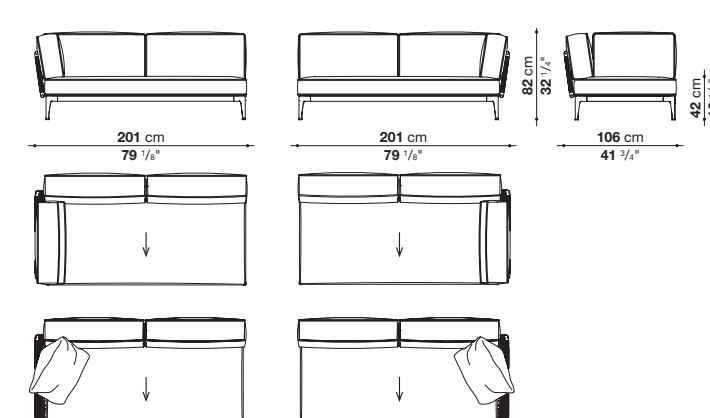

RBR205T\_3

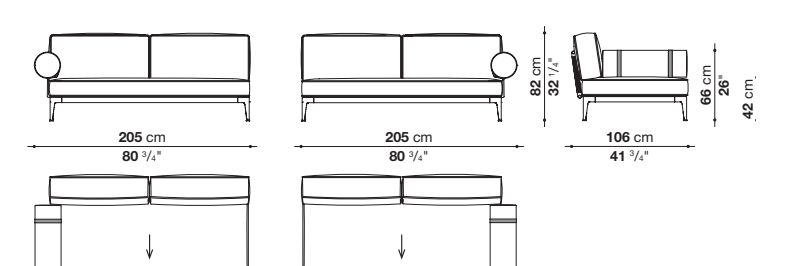

In the drawing the arrow shows the direction of the lines in case of cover with striped fabrics.  
 Nel disegno la freccia indica la direzione delle righe in caso di rivestimento con tessuti rigati.

In the drawing the arrow shows the direction of the lines in case of cover with striped fabrics.  
 Nel disegno la freccia indica la direzione delle righe in caso di rivestimento con tessuti rigati.

# Ribes

## Antonio Citterio • 2019

Inspiration • 141

Terminal elements  
Elementi terminali

RBR205T\_4

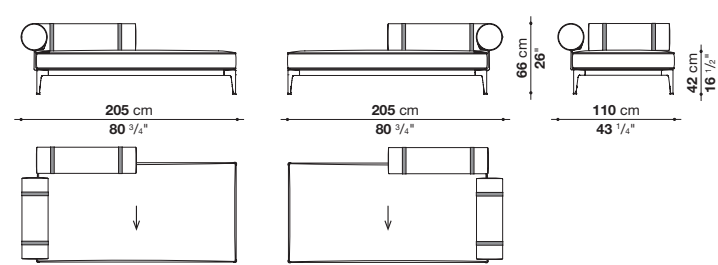

RBR205T\_5

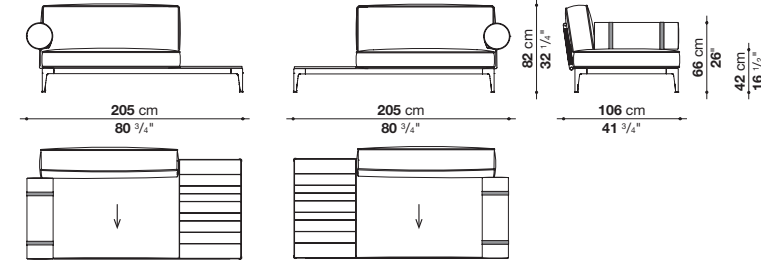

RB201T\_4

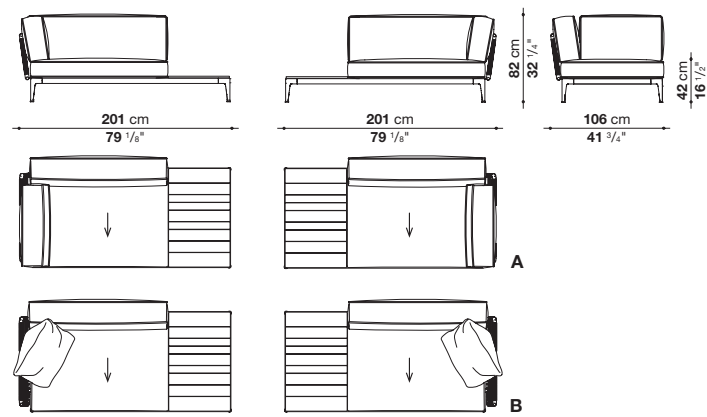

Chaise longue  
Chaise longue

RB141L\_1

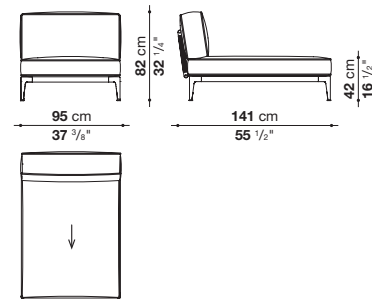

RBR145L

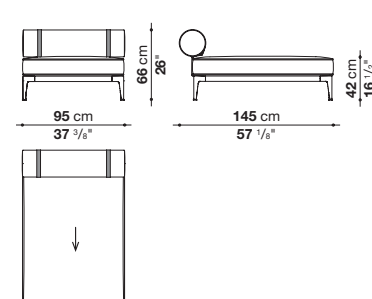

RB141L\_2

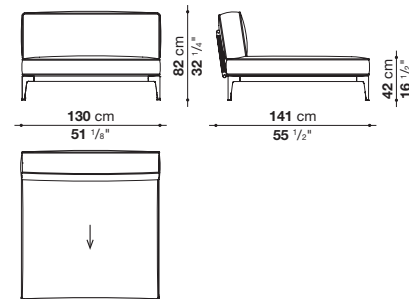

In the drawing the arrow shows the direction of the lines in case of cover with striped fabrics.  
Nel disegno la freccia indica la direzione delle righe in caso di rivestimento con tessuti rigati.

Chaise longue  
Chaise longue

RB201L

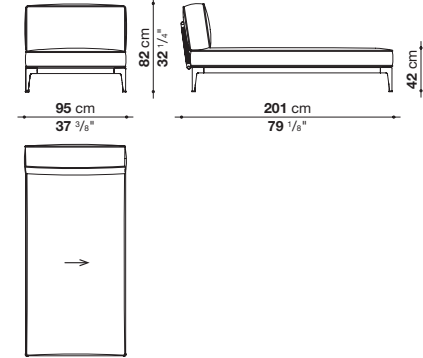

RBR205L

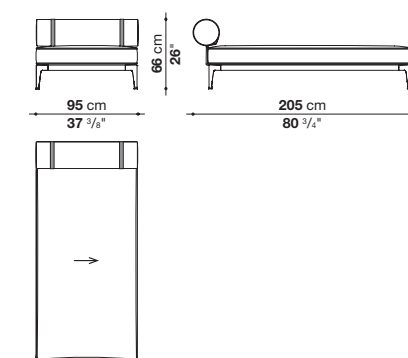

RBR145LB\_1

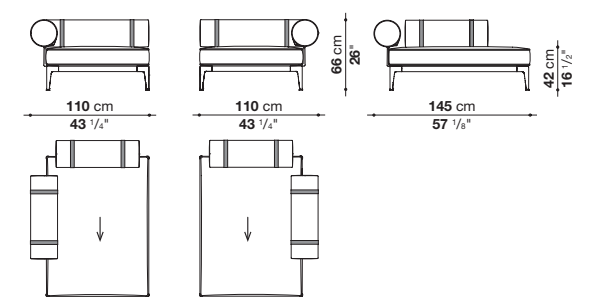

RB141LB\_1

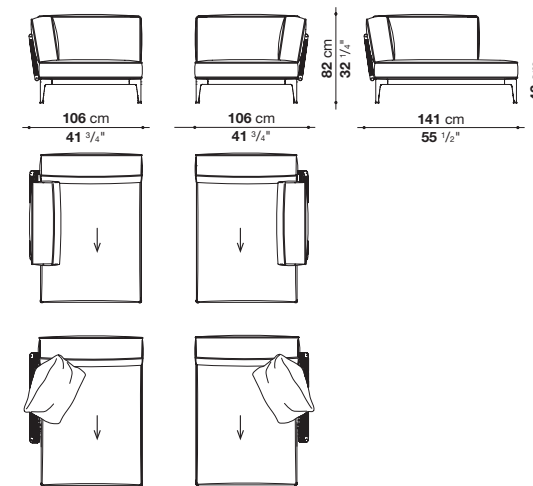

RBR141LB\_1

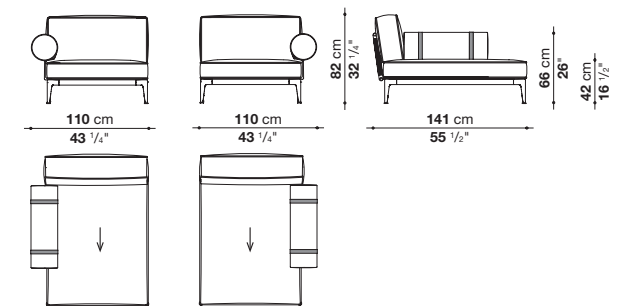

RBR141LB\_2

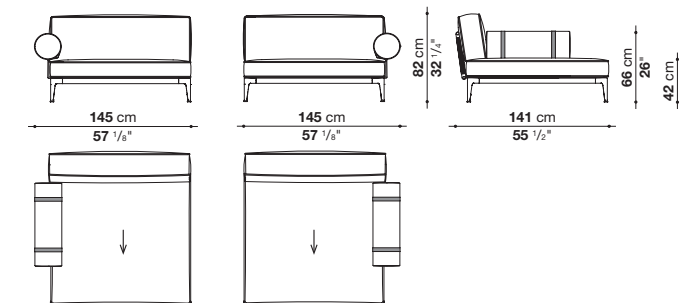

RBR145LB\_2

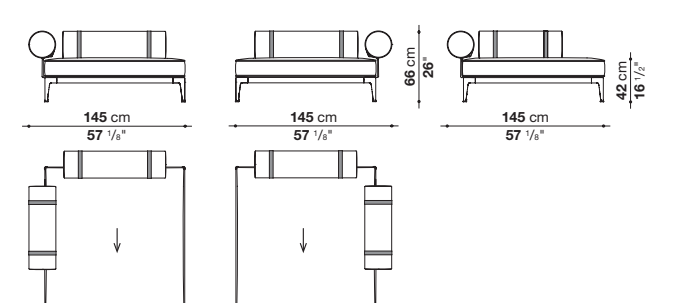

In the drawing the arrow shows the direction of the lines in case of cover with striped fabrics.  
Nel disegno la freccia indica la direzione delle righe in caso di rivestimento con tessuti rigati.

# Ribes

## Antonio Citterio • 2019

Inspiration • 141

Chaise longue  
Chaise longue

RB141LB\_3

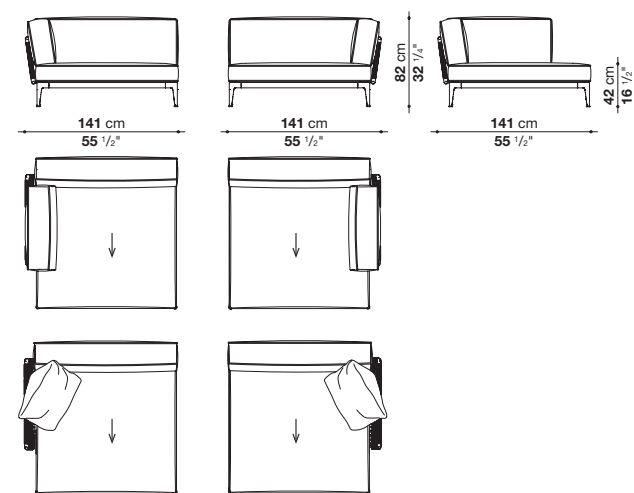

RB201LB\_1

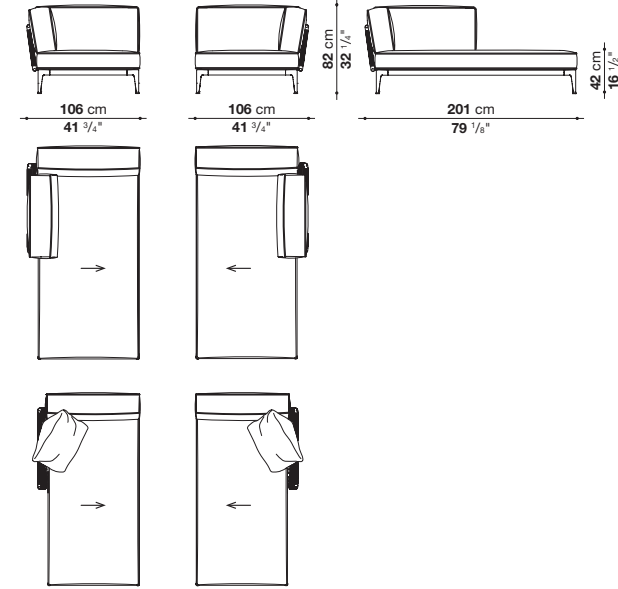

Chaise longue  
Chaise longue

RB201LB\_2

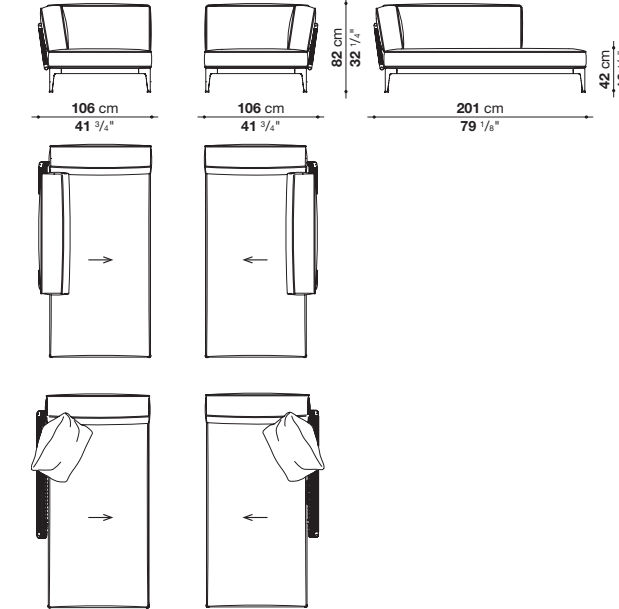

RB141LB\_4

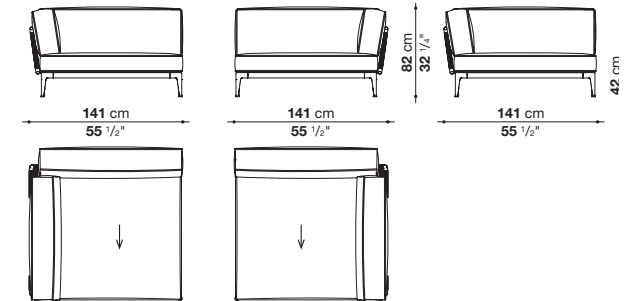

RBR201LB

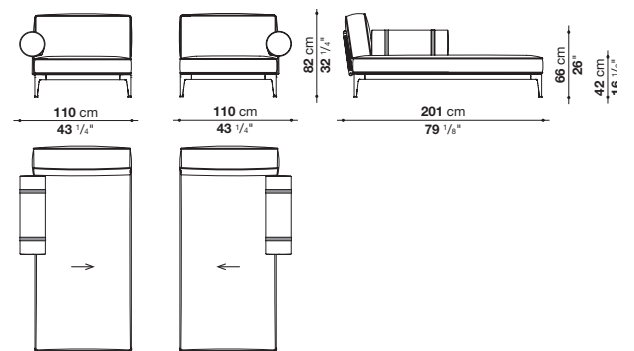

RB141LB\_2

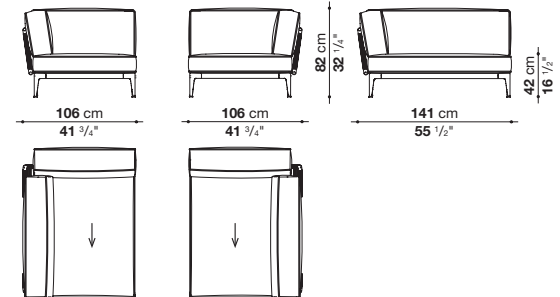

RB141LB\_6

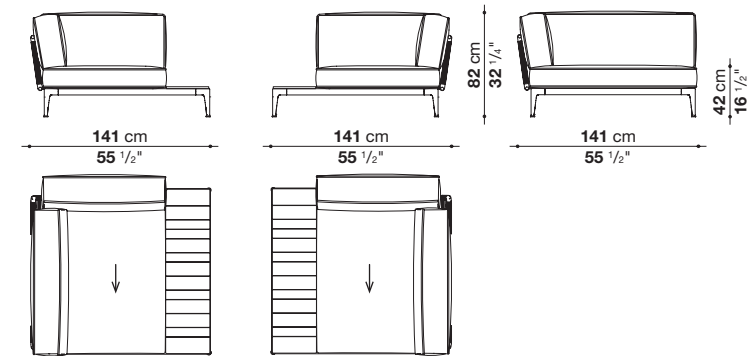

RB141L\_3

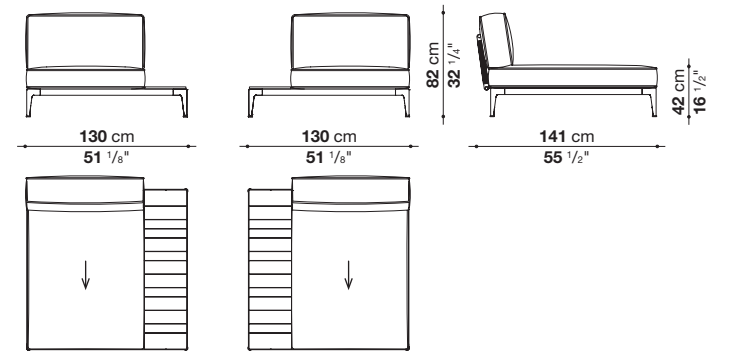

RBR141LB\_3

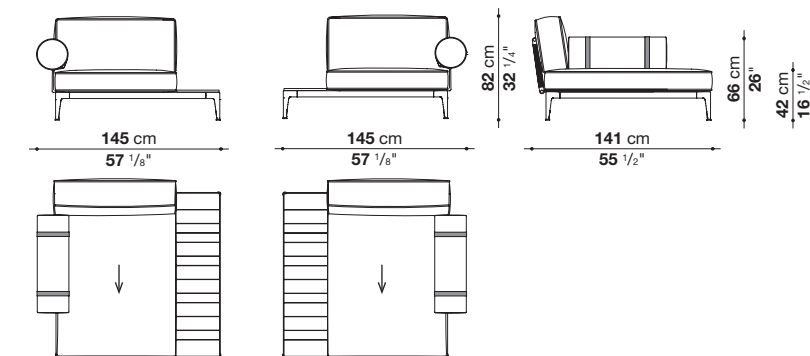

In the drawing the arrow shows the direction of the lines in case of cover with striped fabrics.  
Nel disegno la freccia indica la direzione delle righe in caso di rivestimento con tessuti rigati.

In the drawing the arrow shows the direction of the lines in case of cover with striped fabrics.  
Nel disegno la freccia indica la direzione delle righe in caso di rivestimento con tessuti rigati.

# Ribes

## Antonio Citterio • 2019

Inspiration • 141

### Chaise longue

Chaise longue

RB141LB\_5

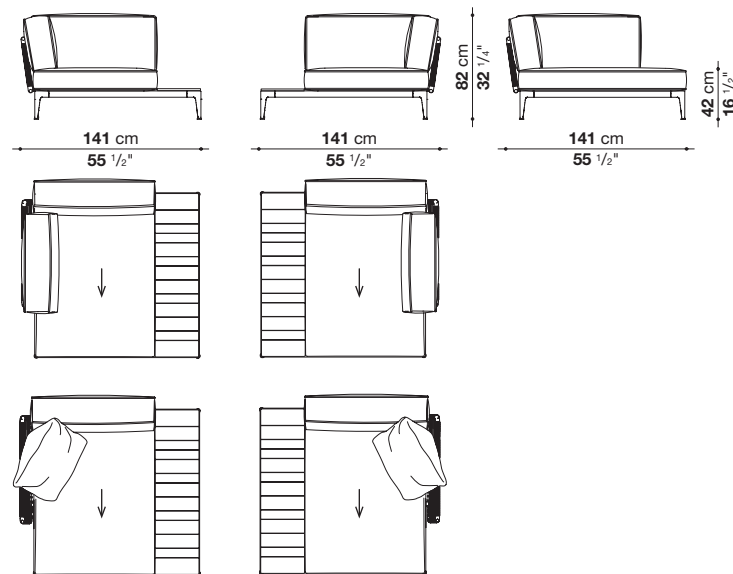

RB201LB\_3

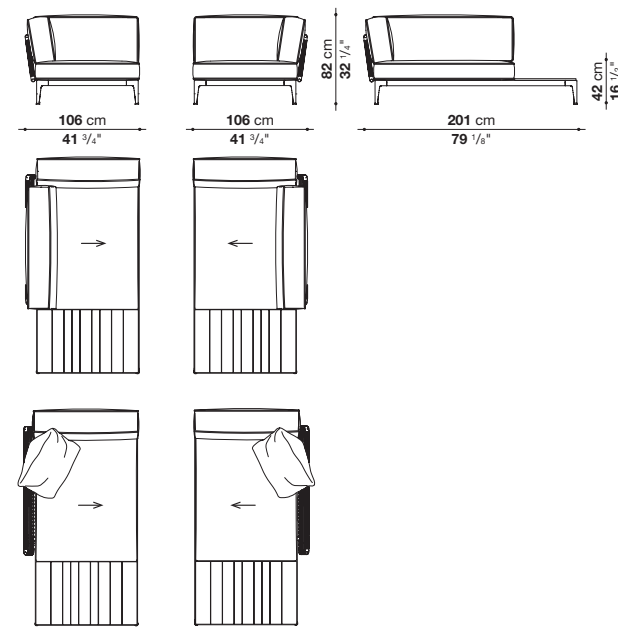

### Ottomans

Pouf

RB130P\_1

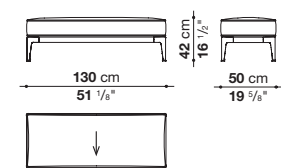

RB130P\_2

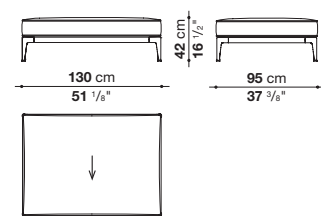

RB130PQ

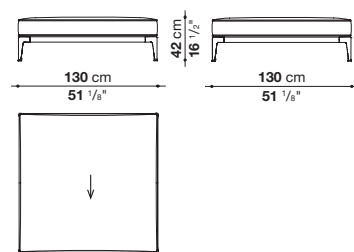

RB190P

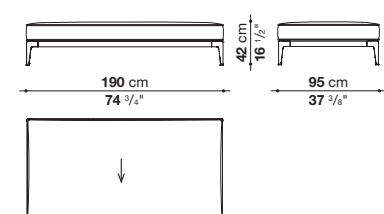

RB130PQ\_1

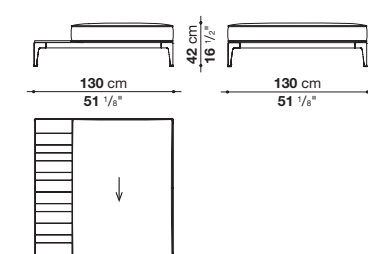

RB190P\_1

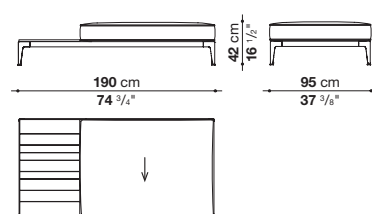

In the drawing the arrow shows the direction of the lines in case of cover with striped fabrics.  
Nel disegno la freccia indica la direzione delle righe in caso di rivestimento con tessuti rigati.

Frame	die-cast aluminium and extrusions with polyester powder painting
Back and roller upholstery	recycled polyester fibre from PET, cover in water repellent polyester fibre
Seat upholstery	shaped polyurethane, recycled polyester fibre from PET, cover in water repellent polyester fibre
Interlacing	polypropylene fibre braid
Seat slats	glass fibre
Seat top section	solid wood
Ferrules	thermoplastic material
Waterproof cover cloth	PES fabric coated on one side in PU
Cover	fabric in limited categories (with profile)

Struttura	pressofusione ed estrusi d'alluminio con verniciatura a polvere poliesteri
Imbottitura schienale e rullo	fibra di poliestere riciclata da PET, fodera in fibra di poliestere con trattamento idrorepellente
Imbottitura sedile	poliuretano sagomato, fibra di poliestere riciclata da PET, fodera in fibra di poliestere con trattamento idrorepellente
Intreccio	treccia in fibra di polipropilene
Doghe seduta	fibra di vetro
inserto piano seduta	legno massello
Puntali	materiale termoplastico
Telo di copertura impermeabile	tessuto PES monospalmato su un lato PU
Rivestimento	tessuto in categorie limitate (con profilo)

### Frame and interlacing matching

Abbinamento struttura e intreccio

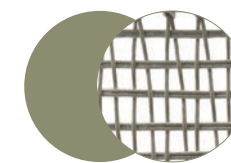

0431S

sage frame / natural polypropylene  
struttura salvia / polipropilene naturale

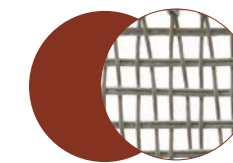

0721A

clay frame / natural polypropylene  
struttura argilla / polipropilene naturale

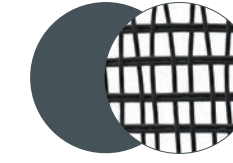

0132N

anthracite frame / anthracite polypropylene  
struttura antracite / polipropilene antracite

### Frame

Struttura

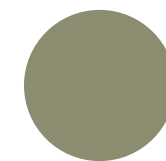

0427S

sage painted  
verniciato salvia

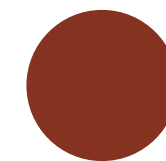

0750A

clay painted  
verniciato argilla

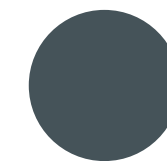

0236B

anthracite painted  
verniciato antracite

### Seat, back cushion profile and roller webbing

Profilo cuscino sedile, schienale e cinghe rullo

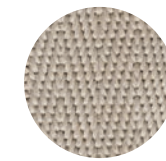

0041E

cream white  
bianco panna

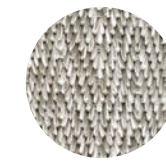

0082N

natural  
naturale

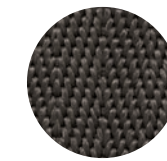

0054G

dark grey  
grigio scuro

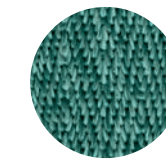

00585A

aquamarine  
acquamarina

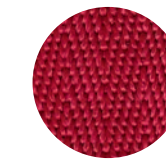

0075R

red  
rosso

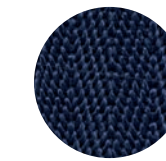

0095B

blue  
blu

The colours and materials shown are an indication. Images not in scale.  
La tonalità dei colori e dei materiali è indicativa. Immagini non in scala.

## Ribes

### Antonio Citterio • 2019

Inspiration • 141

The textile choice is also extensive and colourful with designs that have been inspired by traditional fabrics collected during numerous trips to South America, reinterpreted and redesigned using very clear colour schemes that still leave a wide choice of different combinations allowing maximum customisation. The seat, back and arm cushions can be covered as desired in wide or narrow-striped, dotted or singlecolour material, all in various shades that coordinate with each other. Colored profiles, are available in cream white, natural, dark grey, aquamarine, red and blue, giving definition to the upholstery and allowing for a further degree of customization.

Anche la proposta tessile è ricca e colorata, con fantasie che si ispirano a tessuti tradizionali raccolti nel corso di numerosi viaggi in Sudamerica, reinterpretati e ridisegnati secondo schemi cromatici ben precisi, che lasciano tuttavia grande libertà di scelta negli abbinamenti così da offrire innumerevoli possibilità di personalizzazione. I cuscini sedile, schienale e bracciolo possono essere vestiti a piacere con tessuti a righe larghe, righe strette, puntinati e uniti, tutti in varie tonalità tra loro coordinabili. Profili colorati, da scegliere tra il bianco panna, naturale, grigio scuro, acquamarina, rosso e blu sottolineano i rivestimenti e consentono un ulteriore grado di personalizzazione.

2570810  
Elisir



2563800  
Agate

2570820  
Elisir

2570815  
Elisir

0095B  
blue webbing  
and profile  
cinghie e  
profilo blu

0721A  
clay frame  
struttura  
argilla

2570110  
Elisir



2570207  
Elisir

2570115  
Elisir

2570120  
Elisir

0075R  
red webbing  
and profile  
cinghie e  
profilo rosso

0431S  
sage frame  
struttura  
salvia

2569840  
Ermitage



2563700  
Agate

2570720  
Elisir

0082N  
natural webbing  
and profile  
cinghie e  
profilo naturale

0132N  
anthracite frame  
struttura  
antracite

# Ribes

## Antonio Citterio • 2019

Inspiration • 141

Product compositions/Esempi di composizioni  
Recommended combinations/Abbinamenti suggeriti



2570810 Elisir  
2570815 Elisir  
2570820 Elisir

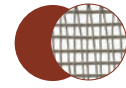

0721A  
clay frame natural  
polypropylene  
struttura argilla  
polipropilene naturale

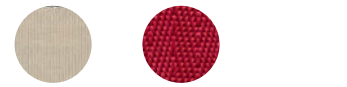

2570207 Elisir  
0075R red profile/profilo rosso



2570810 Elisir  
2570815 Elisir  
2570820 Elisir

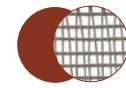

0721A  
clay frame natural  
polypropylene  
struttura argilla  
polipropilene naturale



0075R  
red profile/profilo rosso

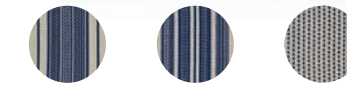

2570810 Elisir  
2570815 Elisir  
2570820 Elisir



0721A  
clay frame natural  
polypropylene  
struttura argilla  
polipropilene naturale

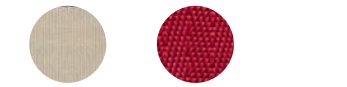

2570207 Elisir  
0075R red profile/profilo rosso



2570110 Elisir  
2570115 Elisir



0750A  
clay painted  
verniciato argilla

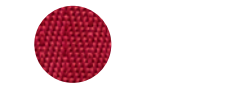

0075R  
red profile/profilo rosso



2570410 Elisir  
2570415 Elisir  
2570420 Elisir



0431S  
sage frame natural  
polypropylene  
struttura salvia  
polipropilene naturale



0082N  
natural profile/profilo naturale



2570810 Elisir  
2570815 Elisir  
2570820 Elisir



0456T  
natural teakwood  
teak naturale



0721A  
clay frame natural  
polypropylene  
struttura argilla  
polipropilene naturale



2570207 Elisir  
0082N natural profile/profilo naturale

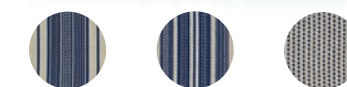

2570810 Elisir  
2570815 Elisir  
2570820 Elisir



0750A  
clay painted  
verniciato argilla



0456T  
natural teakwood  
teak naturale

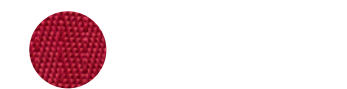

0075R  
red profile/profilo rosso



2570815 Elisir  
2570120 Elisir  
2530795 Loreo



0750A  
clay painted  
verniciato argilla



0456T  
natural teakwood  
teak naturale

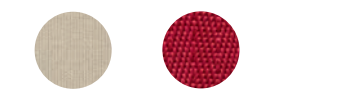

2570207 Elisir  
0075R red profile/profilo rosso

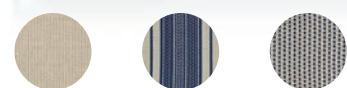

2570207 Elisir  
2570810 Elisir  
2570820 Elisir



0721A  
clay frame natural  
polypropylene  
struttura argilla  
polipropilene naturale



0082N  
natural profile/profilo naturale



2570410 Elisir  
2570415 Elisir  
2570420 Elisir



0431S  
sage frame natural  
polypropylene  
struttura salvia  
polipropilene naturale



0082N  
natural profile/profilo naturale



2570110 Elisir  
2570115 Elisir  
2570120 Elisir



0236B  
anthracite painted  
verniciato antracite

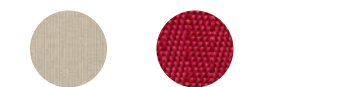

2570207 Elisir  
0075R red profile/profilo rosso



2570810 Elisir  
2570815 Elisir  
2570820 Elisir



0750A  
clay painted  
verniciato argilla

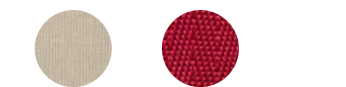

2570207 Elisir  
0075R red profile/profilo rosso

## Spool Outdoor

Piero Lissoni • 2020  
Inspiration • 298



Spool, born as indoor product, maintains its recognizable shape and it is now proposed in the stoneware outdoor version, available in six different vivid colours: white, anthracite, dove grey, sage, clay or ocean blue and it represents a lively punctuation.

Spool, nato nella versione indoor, mantiene la sua forma riconoscibile e viene ora proposto nella versione Outdoor, in gres, declinato in sei varianti di colore dalle vivaci tonalità: bianco, antracite, tortora, salvia, argilla o blu oceano, rappresenta una punteggiatura vivace.

Frame and top	stoneware	Struttura e piano	gres
Fixing bracket	stainless steel	Barra di fissaggio	acciaio inox
Ferrules	thermoplastic material	Puntali	materiale termoplastico

### Small table Tavolino

OS40T

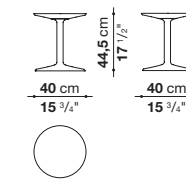

### Top and base-frame Piano e basamento

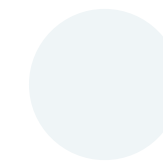

0245B  
glossy white stoneware  
gres bianco lucido

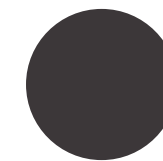

0309A  
glossy anthracite stoneware  
gres antracite lucido

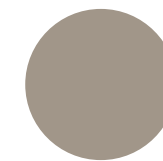

0613T  
glossy dove grey stoneware  
gres tortora lucido



0841S  
glossy sage stoneware  
gres salvia lucido

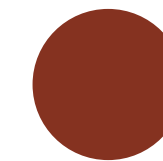

0784A  
glossy clay stoneware  
gres argilla lucido

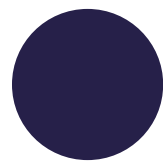

0829B  
glossy ocean blue stoneware  
gres blu oceano lucido

The colour shown are an indication. Image not in scale.  
La tonalità del colore è indicativa. Immagine non in scala.



## Springtime

### Jean-Marie Massaud • 2008

Inspiration • 320



The Springtime complements are available in three different sizes all with a rounded shape and are made of water-repellent material. The products are designed by Jean-Marie Massaud as furnishing elements of an outdoor area that conceptually dialogues between nature and interior spaces.

Realizzati in materiale idrorepellente, i complementi Springtime sono disponibili in tre diverse dimensioni e forme, seppur tutte arrotondate. Sono pensati da Jean-Marie Massaud come elementi di arredo di un'area esterna che dialoga concettualmente tra natura e spazi interni della casa.

Frame and top	Cristalplant Outdoor® (natural mineral filler of phosphate of aluminium with polyester acrylate resin)	Struttura e piano	Cristalplant Outdoor® (carica minerale naturale di idrato d'alluminio con resina poliestere acrilata)
Feet	stainless steel	Piedini	acciaio inossidabile

#### Small tables Tavolini

TST4

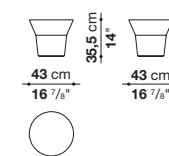

TST7

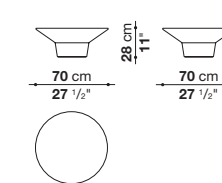

#### Vase Vaso

TST11

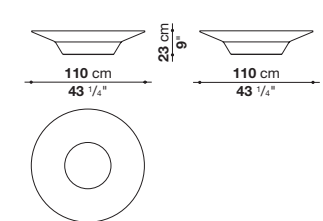

#### Top and frame Piano e struttura

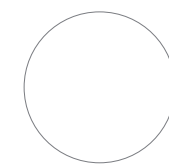

0101G  
white Cristalplant Outdoor®  
Cristalplant Outdoor® bianco

The colour and material shown are an indication. Image not in scale.  
La tonalità del colore e del materiale è indicativa. Immagine non in scala.

# Titikaka

## Naoto Fukasawa • 2009

Inspiration • 314



The waters of Lake Titikaka dictate the shape (and name) of the bench by Fukasawa. This stretch of water lies between Bolivia and Perù, a lake 204 km long and 65 km wide that occupies around 8562 km<sup>2</sup>. This very beautiful place caught the designer's attention, and he tried to capture the movement of the waves to "move" the bench into a new, wavy shape. Titikaka revolutionises the concept of a bench. The traditional typology of the outdoor bench is revamped with contemporary language. It's an impressive piece that resembles a sculpture. Made of teakwood slats that cover the structure to the ground on both front and back, positioned horizontally on the aluminium structure in an original wave-like arrangement to create curves that are both pleasant and ergonomically functional.

Le acque del lago Titikaka dettano la forma (e il nome) della panca firmata Fukasawa. Tra Bolivia e Perù, il bacino di 204 km di lunghezza per 65 di larghezza occupa un'area di 8.562 km<sup>2</sup>. Il luogo di grande suggestione ha colpito la fantasia del designer, che ha cercato di catturare il movimento delle onde per "muovere" la panca dall'inedito andamento ondulatorio. Titikaka rivoluziona il concetto di panchina. Ripropone la tradizionale tipologia della panca per esterni con linguaggio contemporaneo e si impone per la sua presenza scultorea. È realizzata in listelli di teak che scendono a terra su entrambi i fronti e si distribuiscono intorno alla struttura in alluminio con un originale andamento ondulatorio creando curve insieme plastiche e funzionali all'ergonomia della seduta.

Frame	aluminium and solid wood
Ferrules	plastic material

Struttura	alluminio e legno massello
Puntali	materiale plastico

### Bench Panca

TK

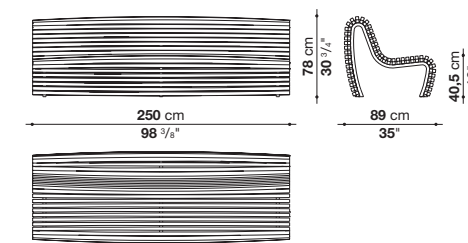

### Frame Struttura



0440T  
natural teakwood  
teak naturale

The colour and material shown are an indication. Image not in scale.  
La tonalità del colore e del materiale è indicativa. Immagine non in scala.

## Tobi-Ishi Outdoor

Edward Barber and Jay Osgerby • 2017

Inspiration • 282



After the debut in the home collection, Edward Barber and Jay Osgerby design Tobi-Ishi Outdoor, the outdoor version of the iconic round dining table and of the low table clearly inspired by Zen. The design duo are great enthusiasts of Japanese art and culture, and the name and inspiration come from the smooth stones “tobi-ishi” used as ornaments in traditional Zen gardens. The overhang of the table and the vertical trapezoidal bases set at right angles generate an essential sculptural figure that appears to change shape depending on the point of observation. Exclusively made of cement, Tobi-Ishi Outdoor comes in two colour variants, grey and anthracite.

Dopo il debutto nella collezione casa, Edward Barber e Jay Osgerby propongono Tobi-Ishi Outdoor, la versione da esterno dell'iconico tavolo da pranzo rotondo e del tavolo basso con esplicite ispirazioni zen. I due designer sono grandi estimatori dell'arte e della cultura giapponese ed il nome e l'ispirazione è un riferimento alle pietre levigate “tobi-ishi” usate con funzione ornamentale nei tradizionali giardini zen. Lo sbalzo del piano e le basi trapezoidali verticali poste ortogonalmente tra loro generano una figura scultorea ed essenziale, che varia costantemente la propria immagine secondo il punto di osservazione. Unica la finitura del tavolo e del tavolo basso realizzati in cemento in due diverse varianti di colore, grigio ed antracite.

Top and legs	cement (Ultra High Performance Concrete)
Coupling plate	galvanized sheet
Feet	stainless steel
Ferrules	thermoplastic material

Piano e gambe	cemento (Ultra High Performance Concrete)
Piastra di aggancio	lamiera zincata
Piedini	acciaio inox
Puntali	materiale termoplastico

### Tavolo Table

OT162

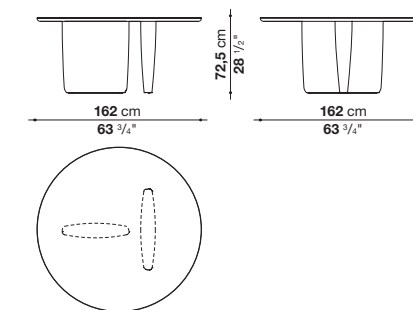

### Low table Tavolo basso

OT146

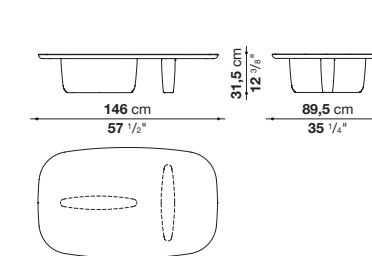

### Top and legs Piano e gambe

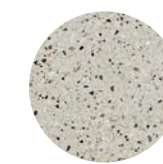

0237G  
grey cement  
cemento grigio

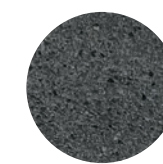

0149A  
anthracite cement  
cemento antracite

The colours and materials shown are an indication. Images not in scale.  
La tonalità dei colori e dei materiali è indicativa. Immagini non in scala.

## Tramae

### unPIZZO • 2020

Inspiration • 300

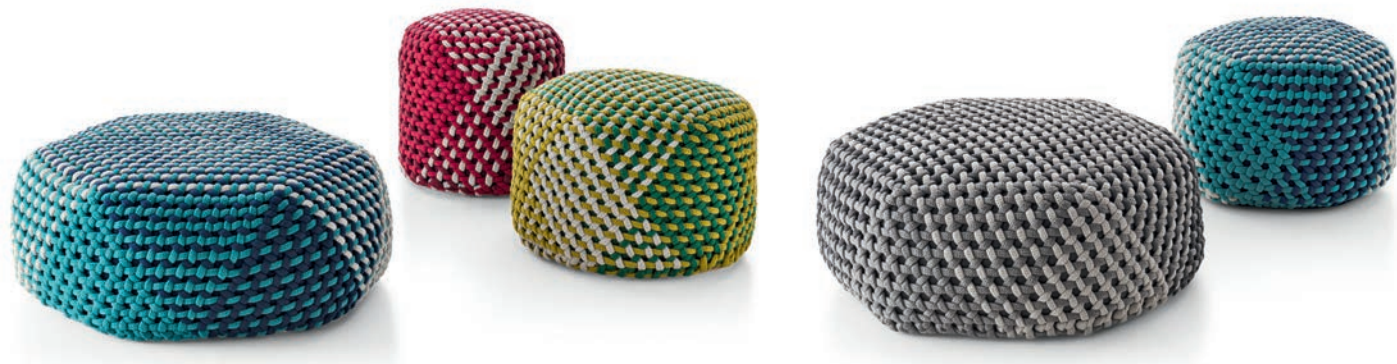

unPIZZO, a design studio and textile handicrafts laboratory specialized in interlacing for furnishing, continues its research on the revival of ancient craft techniques with Tramae, a brand new ottoman for B&B Italia. Available in three dimensions, this small object full of character stands out for its hexagonal shape, which is rounded until the edges are no longer visible. The surface shows a singular dynamic mix of materials and colors that come to life through an exclusive weave that reinterprets the tradition of wicker basket making in a contemporary key. At the end of its lifespan, Tramae can be dismantled completely so that each component can be separated and disposed of in the best way for each material.

unPIZZO, studio di progettazione e artigianato tessile specializzato nell'intreccio per l'arredamento, prosegue la sua ricerca sul recupero di antiche tecniche artigianali con Tramae, un nuovissimo pouf per B&B Italia. Realizzato in tre dimensioni, questo piccolo oggetto pieno di carattere si contraddistingue per la forma esagonale che si arrotonda fino a perdere gli spigoli. La superficie presenta un singolare dinamismo di materiali e colori che prendono vita grazie ad un intreccio esclusivo che rilegge in chiave contemporanea la tradizione della lavorazione dei cesti in vimini. Tramae è completamente disassemblabile. Alla fine del suo ciclo di vita ogni singolo elemento che lo compone si potrà separare e smaltire seguendo il percorso più adatto a ogni materiale.

Frame	polyethylene
Upholstery	shaped polyurethane, cover in water repellent polyester fibre
Interlacing	polypropylene fibre braid
Cover	fabric in limited categories
Waterproof cover cloth	PES fabric coated on one side in PU

Struttura	polietilene
Imbottitura	poliuretano sagomato, fodera in fibra di poliestere con trattamento idrorepellente
Intreccio	treccia in fibra di polipropilene
Rivestimento	tessuto in categorie limitate
Telo di copertura impermeabile	tessuto PES monospalmato su un lato PU

### Ottomans

#### Pouf

TRM47P

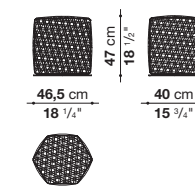

TRM60P

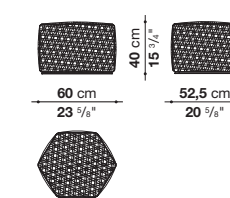

TRM90P

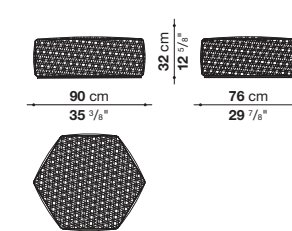

### Interlacing

#### Intreccio

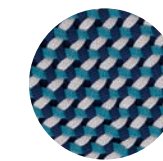

0843B  
night blue polypropylene  
polipropilene blu notte

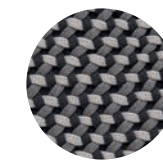

0296G  
dark grey polypropylene  
polipropilene grigio scuro

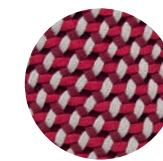

0729B  
bordeaux polypropylene  
polipropilene bordeaux

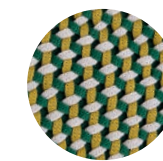

0417V  
green polypropylene  
polipropilene verde

The colours and materials shown are an indication. Images not in scale.  
La tonalità dei colori e dei materiali è indicativa. Immagini non in scala.

Twist  
B&B Italia CR&S · 2018  
Inspiration • 328



Carpet	braided ropes with dyed Olyna FLYER® fibre
Composition	100% polyolefin

Tappeto	corde intrecciate con fibra tinta Olyna FLYER®
Composizione	100% poliolefine

Carpets  
Tappeti

TW201

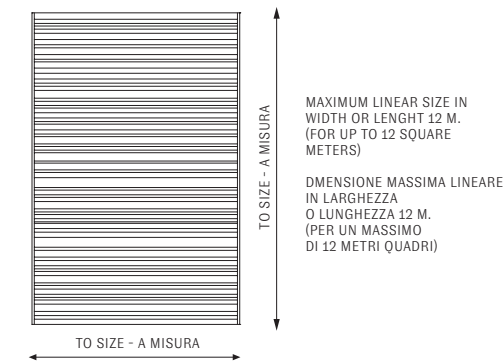

TW200

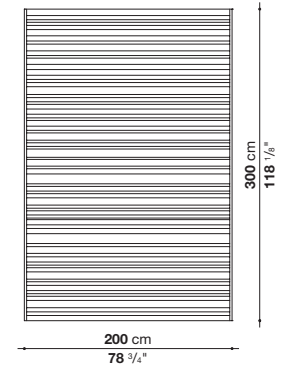

TW250

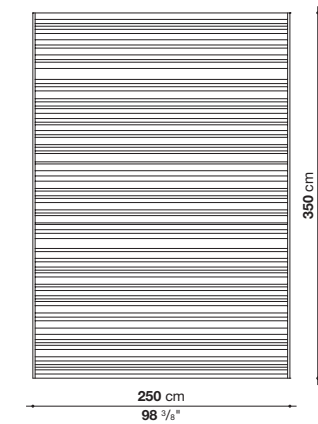

TW300

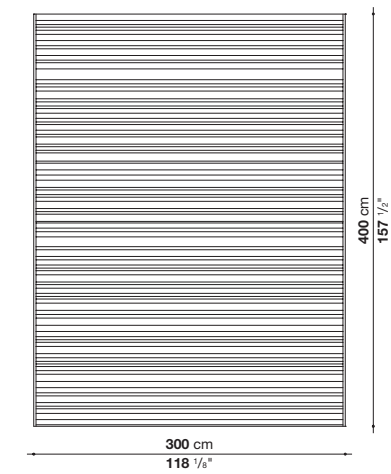

0239C  
rope polyolefin  
poliolefine corda

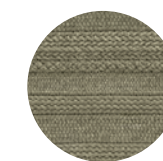

0402V  
green polyolefin  
poliolefine verde

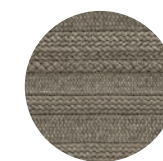

0292T  
tortora polyolefin  
poliolefine tortora

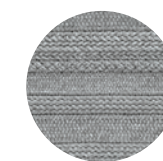

0358G  
grey polyolefin  
poliolefine grigio

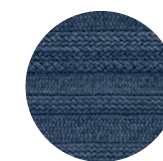

0832B  
blue polyolefin  
poliolefine blu



0318A  
anthracite polyolefin  
poliolefine antracite

The colours and materials shown are an indication. Images not in scale.  
La tonalità dei colori e dei materiali è indicativa. Immagini non in scala.

## White Collection

### Marcel Wanders • 2008

Inspiration • 318



Frame

enamelled ceramic

Struttura

ceramica smaltata

## Vases

Vasi

AB20046B

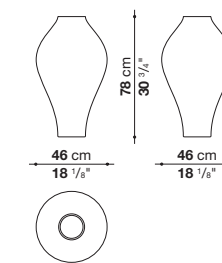

AB20047B

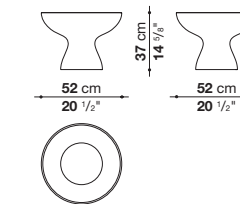

## Stool

Sgabello

AB20048B

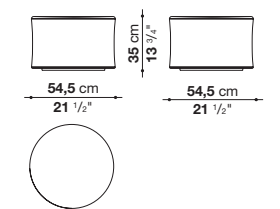

## Frame

Struttura

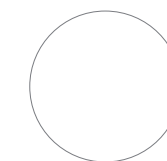
white  
bianco

## Fabrics Tessuti



Agate 100

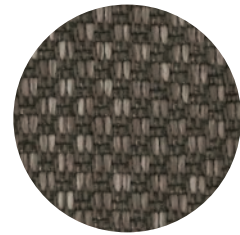

Agate 153



Agate 207



Agate 251

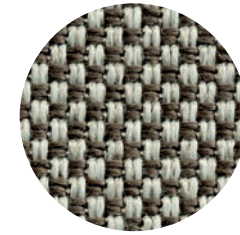

Agate 257

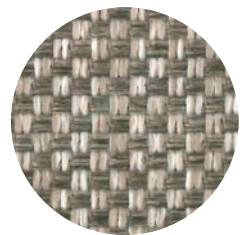

Agate 287



Agate 350

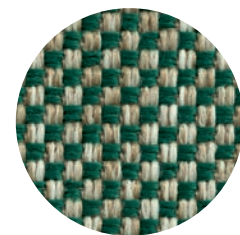

Agate 400

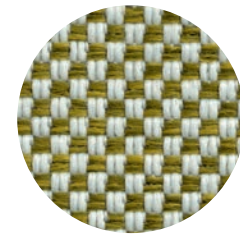

Agate 410

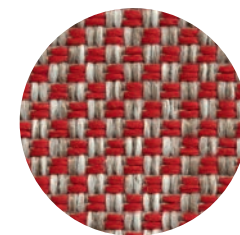

Agate 700

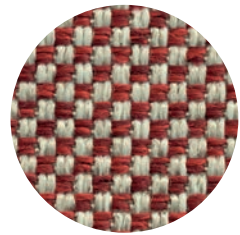

Agate 751

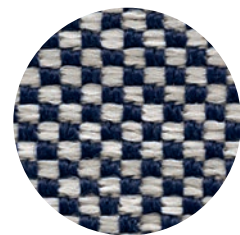

Agate 800

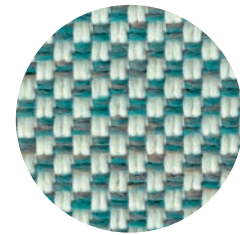

Agate 810

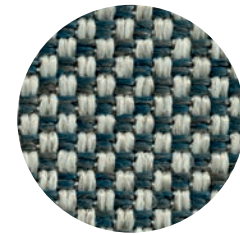

Agate 851



Alceo 100

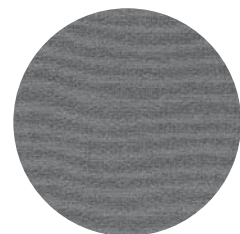

Alceo 255



Alceo 258

## Fabrics Tessuti

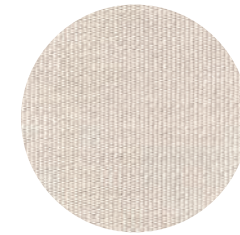

Aliseo 102

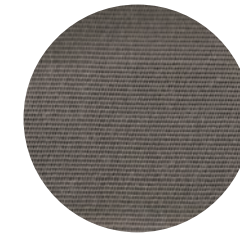

Aliseo 255

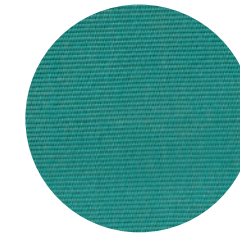

Aliseo 403

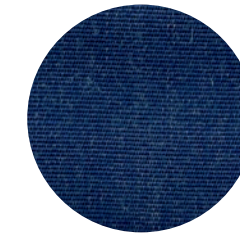

Aliseo 800



Bali 100

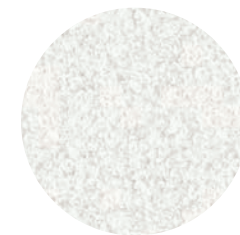

Elide 100



Elide 102

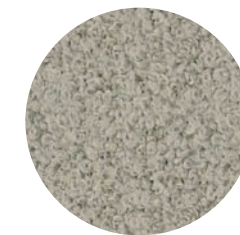

Elide 280

## Fabrics Tessuti

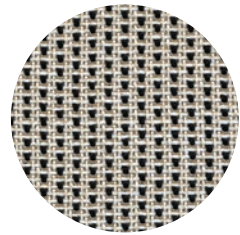

Elisir 120

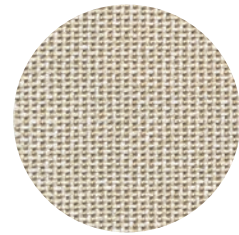

Elisir 207

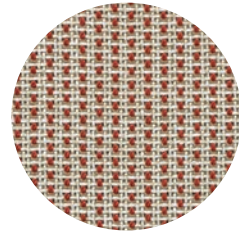

Elisir 320

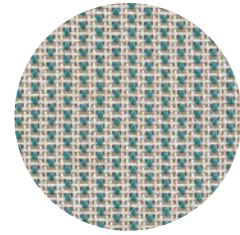

Elisir 420

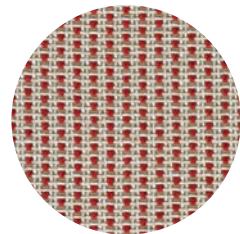

Elisir 720

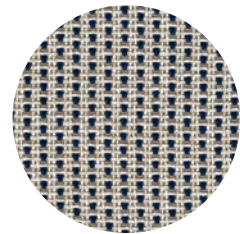

Elisir 820



Elisir 110

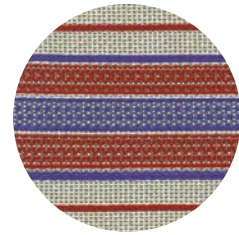

Elisir 310

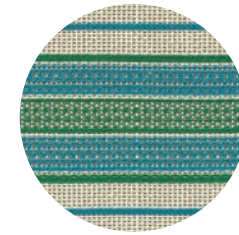

Elisir 410



Elisir 810



Elisir 115



Elisir 315



Elisir 415



Elisir 815

The colours and materials shown are an indication. Images not in scale.  
La tonalità dei colori e dei materiali è indicativa. Immagini non in scala.

## Fabrics Tessuti



Ermitage 101

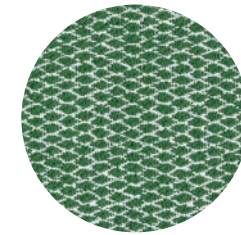

Ermitage 400

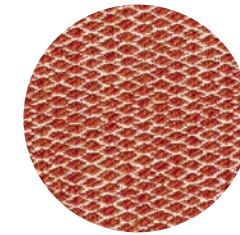

Ermitage 775

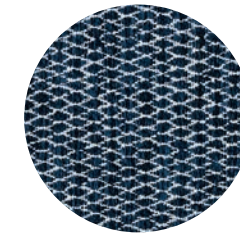

Ermitage 840

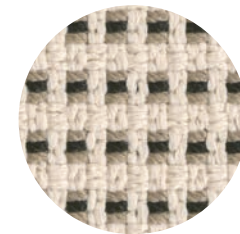

Lamone 275

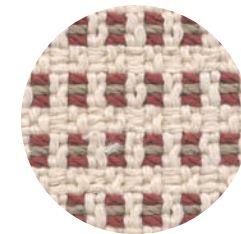

Lamone 385

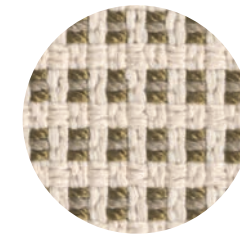

Lamone 425

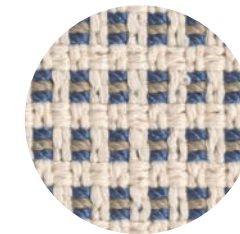

Lamone 895

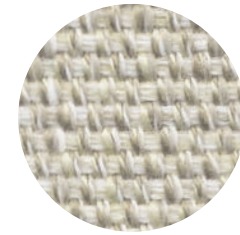

Leila 102

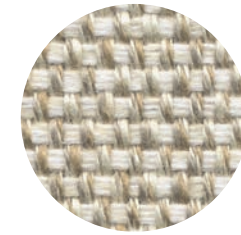

Leila 203

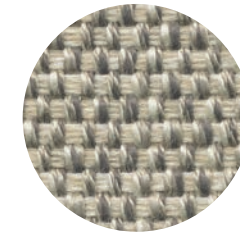

Leila 207

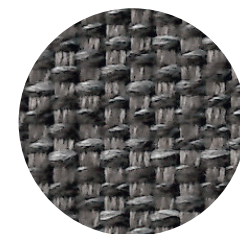

Leila 251

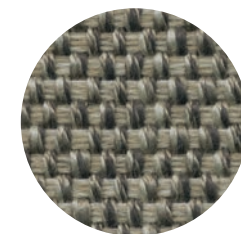

Leila 280

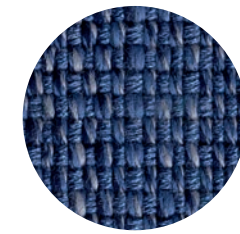

Leila 800

The colours and materials shown are an indication. Images not in scale.  
La tonalità dei colori e dei materiali è indicativa. Immagini non in scala.



### Fabrics Tessuti



Lesia 101



Lesia 207



Lesia 251



Lesia 255



Lesia 280



Lesia 305



Lesia 400

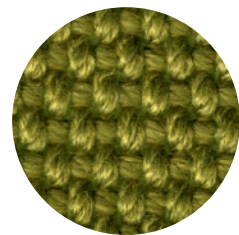

Lesia 407



Lesia 750



Lesia 820



Lesia 830



Lesia 877



Lilia 100

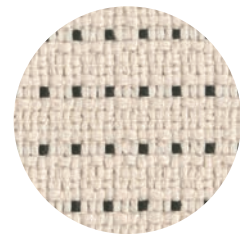

Lilia 111



Lilia 311

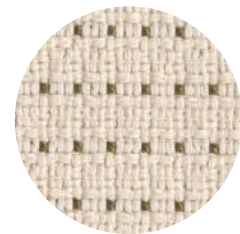

Lilia 411

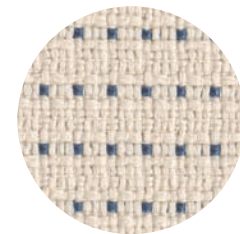

Lilia 811

The colours and materials shown are an indication. Images not in scale.  
La tonalità dei colori e dei materiali è indicativa. Immagini non in scala.

### Fabrics Tessuti



Linaria 207

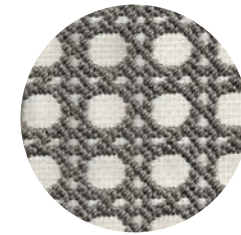

Linaria 251

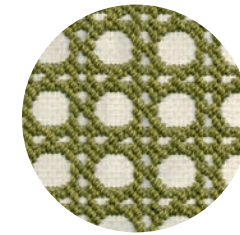

Linaria 407

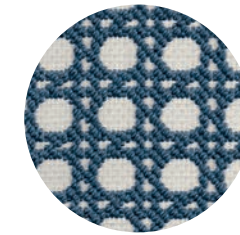

Linaria 830



Lipari 207



Lipari 255



Lipari 280

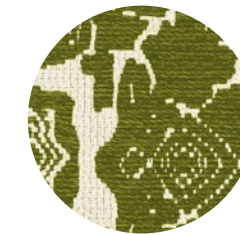

Lipari 407



Lipari 830



Lipari 911



Liri 207



Liri 251



Liri 407



Liri 830

The colours and materials shown are an indication. Images not in scale.  
La tonalità dei colori e dei materiali è indicativa. Immagini non in scala.

## Fabrics Tessuti



Lola 100



Lola 280

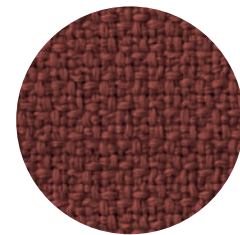

Lola 370



Lola 435

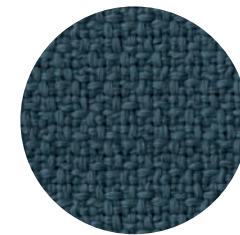

Lola 810

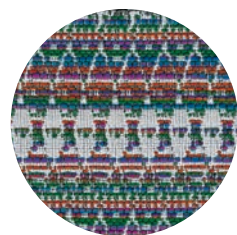

Salinas 715

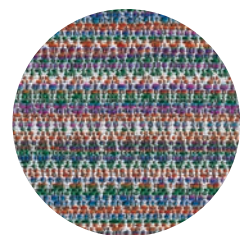

Salinas 735



Samos 450



Samos 750



Samos 877

## Fabrics Tessuti



Saturno 151

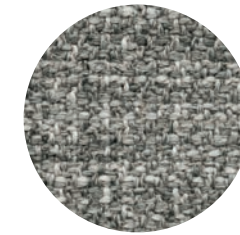

Saturno 258



Saturno 377

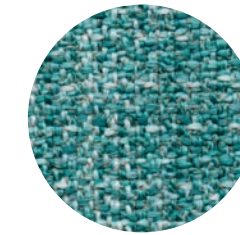

Saturno 403

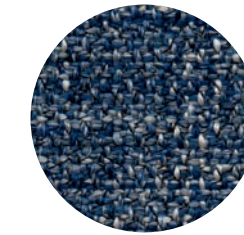

Saturno 800

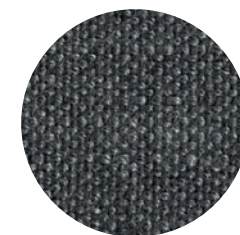

Scirocco 153

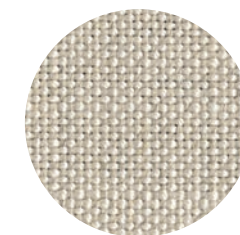

Scirocco 207

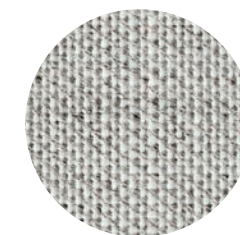

Scirocco 253

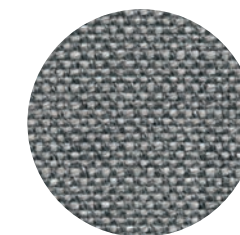

Scirocco 258

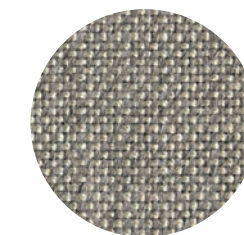

Scirocco 280



Solano 210



Solano 215



Solano 410



Solano 415



Solano 810



Solano 815

## Dedicated fabrics Tessuti dedicati

**Only for Husk Outdoor**  
Solo per Husk Outdoor



Eleo 100



Eleo 200

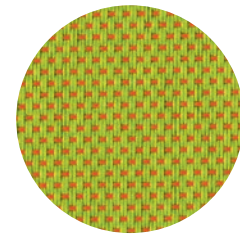

Eleo 450

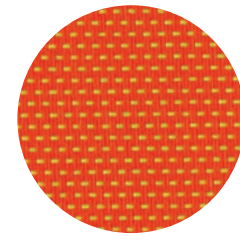

Eleo 570

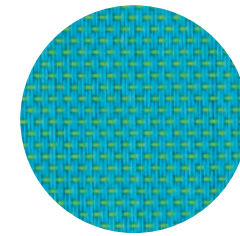

Eleo 810

**Only for Mirto Outdoor**  
Solo per Mirto Outdoor



Stige 102

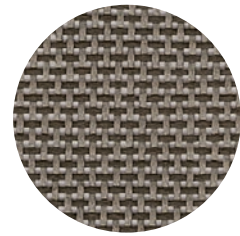

Stige 280

**Only for Cordoba Outdoor and Mirto Outdoor (MI59N)**  
Solo per Cordoba Outdoor e Mirto Outdoor (MI95N)



Laguna 102

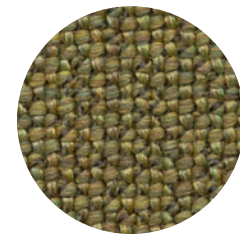

Lamar 401

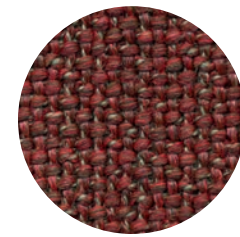

Lamar 760

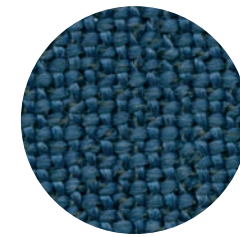

Lamar 890

## Dedicated fabrics Tessuti dedicati

**Only for Oh, it rains!**  
Solo per Oh, it rains!



Silvi 102

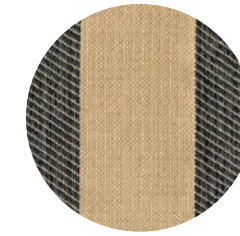

Skiathos 153



Spargi 153

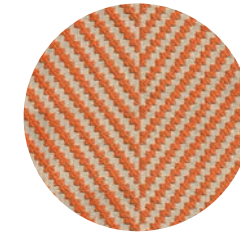

Spargi 570



Symi 153



Symi 570

## Contacts

### Contatti

**B&B ITALIA SPA**  
22060 Novedrate (CO) Italy  
Strada Provinciale 32  
T. + 39 031 795 111  
F. + 39 031 791 592

info.bebitalia.com  
www.bebitalia.com  
www.maxalto.com

**INFO**  
**Italia**  
numero verde 800 018 370  
**USA**  
toll free number 800 872 1697

**All other countries**  
T. + 39 031 795 213

#### B&B ITALIA STORES

##### Europe

**B&B Italia Design Studio**  
**Milano**  
Via Durini 14  
20122 Milano, Italy  
T. + 39 02 764441  
store.milano@d-studio.com

**B&B Italia Saint-Tropez**  
Avenue Maréchal Foch  
Quartier Saint Roch  
83990 Saint-Tropez, France  
T. + 33 4 94 45 77 20  
contact@bebsttropez.fr

**B&B Italia Athens**  
358 Kifisias Ave 15233  
152 33 Chalandri - Athens, Greece  
T. + 30 21 0684 7720  
info@deloudis.gr

**B&B Italia Cyprus**  
41-49 Ag. Nicolaou Street  
2408 Engomi - Nicosia, Cyprus  
T. + 357 7777 15 11  
info@ergohomegroup.com

**B&B Italia Warsaw**  
Burakowska 5/7  
01066 Warsaw  
T. + 48 797167565  
w.lenczowska@mesmetric.com

**B&B Italia Design Studio**  
**Copenhagen**  
Kuglegårdsvej 13-17  
1434 Copenhagen, Denmark  
T. + 45 7872 8200  
info.cph@d-studio.com

**B&B Italia Lyon**  
22 Rue Auguste Comte  
69002 Lyon, France  
T. + 33 9 86 56 21 53  
bebitalia@maisonhomedesign.fr

**B&B Italia München**  
Maximiliansplatz 21  
80333 München, Germany  
T. + 49 89 4613680  
store.muenchen@bebitalia.com

**B&B Italia St. Petersburg**  
Sredniy Prospekt V.o. 83/2  
199106 St. Petersburg,  
Russian Federation  
T. + 7 812 617 43 80  
rossi.info@gmail.com

**B&B Italia London**  
250 Brompton Road  
South Kensington  
SW3 2AS London, U.K.  
T. + 44 20 7591 8111  
info.bromptonroad@bebitalia.com

**B&B Italia Paris**  
35 Rue du Bac  
75007 Paris, France  
T. + 33 1 55 35 14 35  
info@bebitalia.fr

##### Americas

**B&B Italia New York**  
150 East 58th Street  
NY 10155 New York, U.S.A.  
T. + 1 212 758 4046  
info.usa@bebitalia.com

**B&B Italia Madison Avenue**  
135 Madison Avenue  
NY 10016 New York, U.S.A.  
T. + 1 212 889 9606  
info.usa@bebitalia.com

**B&B Italia Boston**  
75 Arlington Street,  
02116 Boston, U.S.A.  
T. +1 617 451 9400  
info@montageweb.com

**B&B Italia Washington DC**  
3320 M Street North West  
DC 20007 Washington, U.S.A.  
T. + 1 202 337 7700  
info.usa@bebitalia.com

**B&B Italia Los Angeles**  
8801 Beverly Boulevard  
CA 90048 Los Angeles, U.S.A.  
T. + 1 310 278 3191  
info@divafurniture.com

**B&B Italia Chicago**  
314 West Superior Street  
IL 60654 Chicago, U.S.A.  
T. + 1 312 335 3855  
info@wpachicago.com

**B&B Italia Miami**  
4141 NE 2nd Avenue Suite 115/114  
FL 33137 Miami, U.S.A.  
T. + 1 786 310 7255  
info.usa@bebitalia.com

**B&B Italia Dallas**  
1707 Oak Lawn Avenue  
TX 75207 Dallas, U.S.A.  
T. + 1 214 389 9513  
info.usa@bebitalia.com

**B&B Italia San Francisco**  
2211 Alameda Street  
CA 94103 San Francisco, U.S.A.  
T. + 1 415 565 7200  
sales@bb-sf.com

**B&B Italia Seattle**  
1300 Western Avenue  
WA 98101 Seattle, U.S.A.  
T. + 1 206 287 9992  
seattle@divafurniture.com

**B&B Italia Houston**  
2016 W. Alabama Street,  
77098 Houston U.S.A.  
T. +1 713 623 1177  
hello@be-design.us

**B&B Italia Sun Valley**  
110 Lindsay Circle  
ID 83340 Ketchum, U.S.A.  
T. + 1 208 928 6379  
info@arsunvalley.com

**B&B Italia São Paulo**  
Avenida Brasil 1653 Jardim America  
01431-001 São Paulo SP, Brazil  
T. + 55 11 3368 6033  
contato@casualmoveis.com.br

**B&B Italia Belo Horizonte**  
Rua Andaluzita 125 Carmo Sion  
30310-030 Belo Horizonte MG, Brazil  
T. + 55 31 3281 4882  
contato@casualmoveis.com.br

## Contacts Contatti

### B&B ITALIA STORES

#### Asia

**B&B Italia Tokyo**  
1, 3F Aoyama Om- Square 2-5-8  
Kita Aoyama,  
107-0061 Minato-ku - Tokyo, Japan  
T. + 81 03 3478 3837  
info@beitalia.co.jp

**B&B Italia Hong Kong**  
31/F 1st floor China Online Center  
333 Lockhart Road Wan Chai  
Hong Kong, China  
T. + 852 2295 6263  
beitalia@colourliving.com

**B&B Italia Beijing**  
No. 5-1-03 1st floor International Hall  
Easyhome at North 4th Ring Road  
Chaoyang District  
100101 Beijing, China  
T. + 86 010 8464 8161  
beb@designspace.com.cn

**B&B Italia Dalian**  
Liju Household 1st floor  
72 Renmin East Road  
Zhongshan District  
116000 Dalian City, China  
T. + 86 411 3998 5686  
glory@dalian-glory.com

**B&B Italia Shanghai**  
Unit L1 W10 No. 168 Hubin Road  
Huangpu District  
200021 Shanghai, China  
T. + 86 021 6330 0606  
info@arealiving.cn

**B&B Italia Nanjing**  
No. 168 Jiangdongzhong Road  
Jianye District  
210019 Nanjing, China  
T. + 86 25 6819 7311  
info@yonglong-furniture.com

**B&B Italia Chengdu**  
Unit 1071-1072 1st floor  
No. 3 Fusen Mall  
No. 18 Shenghe 2nd Road  
Gaoxin District  
610014 Chengdu, China  
T. + 86 177 8069 8361  
info@tinychome.cn

**B&B Italia Jinan**  
A2-4/5, 2F, No.371 Beiyuan Avenue,  
Tianqiao District,  
250031 Jinan Shandong  
T. +86 13805422157  
gx\_jinan@163.com

**B&B Italia Foshan**  
Louvre Mall 5th-6th floor  
Lecong Section of National  
Highway No. 325  
Shunde District  
528315 Foshan, China  
T. + 86 400 1881 222  
louvre@louvre-casa.com

**B&B Italia Wenzhou**  
1st floor Building 1 Wancui Plaza  
121 Sanyou Road  
Lucheng District  
325000 Wenzhou, China  
T. + 86 577 8988 2225  
marketing@womehome.com

**B&B Italia Guangzhou**  
Poly Finance Tai To Wun 4rd floor  
Huangpu Avenue No. 666  
Tianhe District  
510620 Guangzhou, China  
T. + 86 400 188 1222  
louvre@louvre-casa.com

**B&B Italia Taizhou**  
A21 Derlook International Furniture,  
No. 1 Hongxi Road, Hongjia Str.,  
west of the intersection of S226 and  
Donghuan Ave., 318000 Jiaojiang  
District, Taizhou City  
T. +8613616693963  
neo@fashionbond.net

**B&B Italia Shenyang**  
No.103,105 First Floor, Yanlord Casa  
Hub, No.209 Qingnian St.,  
Shenhe District Liaoning Province  
T. +86 13842027688  
lfmyhb@163.com

**B&B Italia Ningbo**  
A-28 1st floor DerLook  
No. 315 Ningchuan Road  
Yinzhou District  
315000 Ningbo, China  
T. + 86 574 8773 1580  
13605740532@qq.com

**B&B Italia Shenzhen**  
S218-S220 Block 10  
Upperhills Shopping Mall  
No. 5001 Huanggang Road  
Wah Fu Street Lotus Merlin Community  
Futian District  
518000 Shenzhen, China  
T. + 86 755 8899 9995  
michellezhang@domustiandi.com

**B&B Italia Wuhan**  
Shop L528 5th floor Heartland 66  
No. 668 Jinghan Street  
Qiaokou District  
430000 Wuhan, China  
T. + 86 131 7968 0909  
344395659@qq.com

**B&B Italia Zhengzhou**  
L1-119-120 LG1-B112 Yongwei  
Muse Park Shopping Mall  
No. 6 Shangwu Dongwu Street  
Jinshui District  
450018 Zhengzhou, China  
T. + 86 371 586 66655  
jessica@uandmilfe.com

**B&B Italia Kaohsiung**  
65-67 Minquan 1st Road  
Lingya District  
80251 Kaohsiung City, Taiwan  
T. + 886 7 332 7676  
service@bonmaison.co

#### Asia

**B&B Italia Taipei**  
2F No. 95 Sec. 2  
Dunhua South Road  
Da'an District  
10682 Taipei City, Taiwan  
T. + 886 2 2755 5855  
service@bonmaison.co

**B&B Italia Taichung**  
No. 211 Chaofu Road  
Xitun District  
40757 Taichung City, Taiwan  
T. + 886 4 2258 5632  
service@bonmaison.co

**B&B Italia Seoul**  
777 Samseong-ro  
Cheongdam-dong  
Gangnam-gu - Seoul, South Korea  
T. + 82 2 3447 6000  
infini@infini.co.kr

**B&B Italia Busan**  
454 Jwadongsunhwan-ro  
Haeundae-gu  
Busan, South Korea  
T. + 82 5 1731 3470  
infini@infini.co.kr

**B&B Italia Ho Chi Minh City**  
22-36 Nguyen Hue Boulevard  
& 57-69F Dong Khoi Street  
Ben Nghe Ward District 1  
Ho Chi Minh City, Vietnam  
T. + 84 286 684 0333  
beitalia@eurasia-concept.com

**B&B Italia Manila**  
Twenty-Four Seven McKinley Building  
24th Street Corner 7th Avenue  
at McKinley Parkway  
1634 Bonifacio Global City, Philippines  
T. + 63 2 8705 9999  
bebitiamanila@focusglobalinc.com

**B&B Italia Ahmedabad**  
FF-1 Circle Opp. Panchvati Auto  
100 feet Road Satellite  
Sarkhej Gandhinagar Road  
380015 Ahmedabad, India  
T. + 91 71 6743 2900  
trenttso@gmail.com

**B&B Italia New Delhi**  
349 1st floor Mehrauli-Gurgaon Road  
next to Sultanpur Metro Station,  
110030 New Delhi, India  
T. + 91 99 9969 3093  
beb@scalahome.in

#### Middle East / Africa

**B&B Italia Dubai**  
Jumeirah 3 beside Offshore  
Sailing Club - Jumeirah St  
1038 Dubai, U.A.E.  
T. + 971 4 346 6932  
baituti@baituti.com

**B&B Italia Beirut**  
Martyr Square, An Nahar Building  
Downtown Beirut, Lebanon  
T. + 961 1 971 444  
beitalia@leccercle.me

**B&B Italia Tel Aviv**  
HaTa'arucha Street 3  
6350903 Tel Aviv-Yafo, Israel  
T. + 972 3 744 9935  
oshrat@theboxfurniture.co.il

**B&B Italia Lusail**  
Doha Design District,  
Msheireb Downtown, DOHA  
T. +974 4404 0800  
info@bluucasa.com

**B&B Italia Johannesburg**  
39 Commerce Crescent  
- Kramerville -  
Sandton, 2031 Johannesburg  
T. +27 106002100  
info@illusso.co.za

# Credits

## Crediti

### Photography

Tommaso Sartori  
Fabrizio Bergamo  
Salva Lopez

### Styling

Studio Salaris  
Patrizia Cantarella  
pc  
studio  
Monica Montemartini  
Simona Silenzi Studio  
Francesca Santambrogio

### Printing

Nava  
Press

### Copyright

CR&S B&B Italia  
March 2023

### Thanks to

Atmosphere d'Ailleurs, As'art, Ay Illuminate,  
Barbera/Madelli, Charlotte Kidger, Claudio  
Pulicati, Compasso Gallery, concrete sculpture  
by Marco Olgio, Danese, Francesco Perego,  
Gaetano di Gregorio, Galleria Rossana Orlandi,  
Giacomelli giardini, Ilaria Bianchi, Industreal,  
Kommod Luca Leandri- Galleria Amuralab,  
Lola Montes Schnabel, Officine Saffi, Oluce,  
Pallodi, Pinetti, Pulpo, Scandola Marmi, Serax,  
Sfera, Sergio Maria Calatroni, Terrecotte Poggi  
Ugo, Vetrofuso Vicara, Viv Lee, 101 Copenhagen

### All lighting courtesies

Flos Outdoor

Descriptions and pictures of products included in this catalogue have an indicative value only and are not binding for products' use. B&B Italia reserves the right to modify their products without prior notification. For further technical information of the products, please contact the authorised dealer closest to you (see [www.bebitalia.com](http://www.bebitalia.com)).

La descrizione e le immagini dei prodotti del presente catalogo sono puramente indicative e non possono essere considerate vincolati ai fini del loro utilizzo. B&B Italia si riserva di apportare ai prodotti le modifiche che ritiene più opportune, in qualsiasi momento e senza preavviso. Per ulteriori informazioni sulle caratteristiche tecniche dei prodotti, invitiamo a consultare il sito [www.bebitalia.com](http://www.bebitalia.com) dove troverete l'elenco dei rivenditori autorizzati a cui rivolgervi.